

# 195 ECM HEAT RECOVERY VENTILATOR



## ENGINEERING DATA

### THERMALLY CONDUCTIVE, PATENTED ALUMINUM CORE

The cross-flow heat recovery core transfers heat between the two airstreams. The two cores are arranged for highly efficient counter current airflow.

### MOTORS AND BLOWERS

High efficiency electronic commutate ECM motor, for maximum energy savings. Each airstream has one centrifugal blower, with multiple fan speed operations driven by on double shaft motor.

### FILTERS

Washable air filters in exhaust and supply air streams.

### MOUNTING

Four threaded inserts at corners of the cabinet designed to accept the "s" hooks and hanging straps supplied with the unit.

### DEFROST

Damper defrost system.

### CASE

Twenty gauge prepainted galvanized steel for superior corrosion resistance. Insulated to prevent exterior condensation. Drain connections 2 - 1/2 in. (12 mm) OD. Balancing ports are located on door.

### ELECTRONICS

The DXPLO2 control included with the unit can be wall mounted in a central location of the home. 3 wire 20 gauge (min.) 100 ft length (max.).

## WARRANTY

Units carry a lifetime warranty on the HRV core and a 5 year replacement parts warranty.

## OPTIONAL ACCESSORIES:

**Dual Hood**  
99-190  
99-194



**Weather Hood**  
99-185  
99-186  
99-187



**TechGrille**  
99-EAG4  
99-EAG5  
99-EAG6  
99-EAG8



**Terminator Fitting**  
99-TM4  
99-TM5  
99-TM6



## LIFEBREATH CONTROL OPTIONS

FEATURES	99-DXPLO2	99-BC02	99-BC03	99-BC04
5 speed fan operation on each mode	✓			
2 speed fan operation (Low/High)		✓		✓
Continuous low speed fan operation			✓	
Humidity control through adjustable Dehumidistat	✓	✓	✓	
Large digital LCD screen	✓			
LED status indicator lights		✓	✓	✓
Continuous Ventilation	✓		✓	
Continuous Recirculation	✓		✓	
20 ON/40 OFF	✓			
10 ON/50 OFF	✓			
20 ON/40 Recirculation	✓		✓	✓
20/40/60 min. High speed override button	✓			
Compatible with 99-DETO2 Wireless Timer	✓	✓	✓	✓
3 wire connection	✓	✓	✓	✓

## TIMER OPTIONS

**99-DETO1 - Lifebreath 20/40/60 Minute Timer**  
Initiates high speed Ventilation for 20, 40 or 60 minutes. 3 wire connection.

**99-DETO2  
Wireless Lifebreath 20/40/60 Minute Timer**  
Initiates high speed Ventilation for 20, 40 or 60 minutes. Wirelessly connects to main control for ease of installation. 40' approximate range. Exclusive to LifeBreath.

**99-RX02 - Wireless Lifebreath Repeater**  
Extends range of 99-DETO2 Wireless Timers. Plugs into 120V power outlet. Wirelessly connects to main control and 99-DETO2. Install at halfway point between timer and main wall control if timer is out of range.



99-DXPLO2



99-DETO2

**LIFEBREATH**  
Indoor Air Systems

www.lifebreath.com

# 195 ECM HEAT RECOVERY VENTILATOR



**LIFE BREATH**

## PERFORMANCE (HVI CERTIFIED)

IN. W.G. (PA)	0.1 (25) CFM (L/s)	0.2 (50) CFM (L/s)	0.3 (75) CFM (L/s)	0.4 (100) CFM (L/s)	0.5 (125) CFM (L/s)	0.6 (150) CFM (L/s)
Net Supply Airflow	206 (97)	199 (94)	190 (90)	181 (85)	171 (81)	159 (75)
Gross Supply Airflow	218 (103)	210 (99)	201 (95)	191 (90)	180 (85)	167 (79)
Gross Exhaust Airflow	178 (84)	171 (81)	168 (79)	165 (78)	159 (75)	145 (69)

ELECTRICAL SPECIFICATIONS	
VAC @ 60Hz	120
Watts / Low Speed	22
Watts / High Speed	134
Amp Rating	1.4

Sensible Effectiveness (ASE) @ 64 CFM (30 L/s)	32°F (0°C)	87%
Sensible Efficiency (SRE) @ 64 CFM (30 L/s)	32°F (0°C)	79%
Sensible Efficiency (SRE) @ 104 CFM (49 L/s)	32°F (0°C)	76%
Sensible Efficiency (SRE) @ 121 CFM (57 L/s)	-13°F (-25°C)	64%

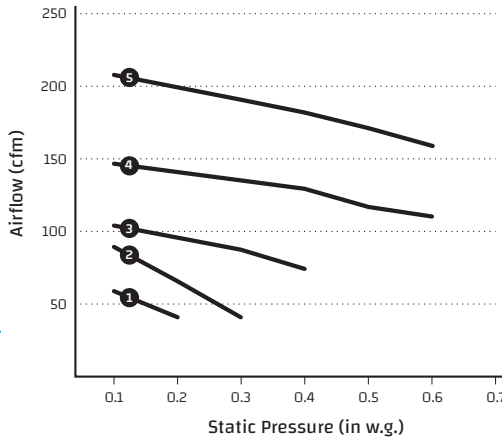

**WEIGHT:**  
**88 LBS (40 KG)**

**SHIPPING WEIGHT:**  
**92 LBS (41.8 KG)**

**NOTE:**

Front clearance of 25 in. (635 mm) is recommended for servicing unit. Outside ports, 6 in. (150 mm). Inside ports, 7 in. (178 mm).



## DIMENSIONS

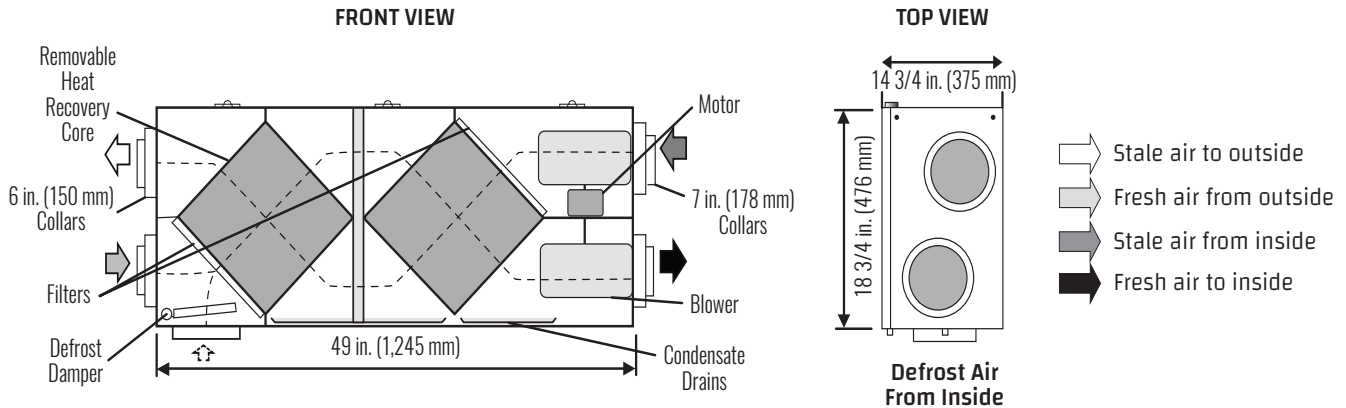

Date: \_\_\_\_\_

Tag: \_\_\_\_\_

Project: \_\_\_\_\_ Qty: \_\_\_\_\_

Engineer: \_\_\_\_\_

Control: \_\_\_\_\_

Contractor: \_\_\_\_\_

Supplier: \_\_\_\_\_

Quote #: \_\_\_\_\_

Submitted By: \_\_\_\_\_

Timer: \_\_\_\_\_ Timer Qty: \_\_\_\_\_

### WARRANTY

Units carry a lifetime warranty on the HRV core and a 5 year replacement parts warranty.

All units conform to CSA and UL standards



www.lifebreath.com