

**ENGINEERING DATA**

**MOTORS AND BLOWERS**

High efficiency PSC Motor - 150 cfm @ .4" WC 110 watts - 120 VAC. Standard three prong plug to receptacle. The TFP is equipped with a standard power supply of 5'5" (1.6 meters) cable.

**COLLECTOR AND FILTER**

One replaceable TFP collector and one replaceable HEPA filter. Easy to remove for cleaning and replacement. Annual inspection recommended.

**MOUNTING THE AIR CLEANER - 4 OPTIONS**

1. Mount to the furnace return
2. Mount between the HRV and the furnace
3. Hang from a joist and duct to the furnace
4. Stand alone installation

**OPTIONS**

**65-502R** One replacement HEPA Filter

**65-503R** One replacement TFP Collector

**99-TFP** **Optional Installation Kit**

- Two 7 in Duct Connection Collars
- 12.5 in length of 7 in non-insulated flex duct
- Four nylon zip ties

**DIMENSIONS TFP3000HEPA**

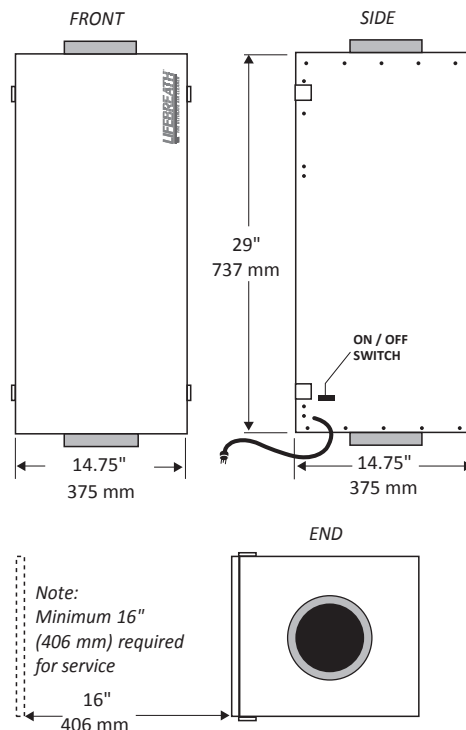

All duct connections are 7" (178 mm)

**Model TFP3000HEPA Particle Capture Rate**

Particle Size (microns)	Percentage Caught
.3 or more	99.7%

- Model TFP3000HEPA - 99.97% efficient at .3 microns.
- A human hair is 100 microns wide.
- Spores and pollen are all larger than 8 microns.
- A micron is 1/1000 of a millimeter, or less than 1/2 of 1/10,000 of an inch.

**WARRANTY**

Units carry a 5 year replacement parts warranty. No warranty on collector/filter.



All units conform to CSA and UL standards

NOTE: All specifications are subject to change without notice.

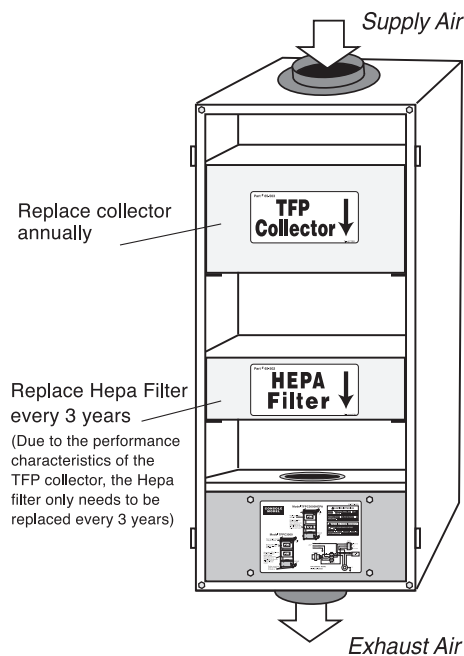

Date: \_\_\_\_\_

Contractor: \_\_\_\_\_

Tag: \_\_\_\_\_ Qty: \_\_\_\_\_

Supplier: \_\_\_\_\_

Project: \_\_\_\_\_

Quote #: \_\_\_\_\_

Engineer: \_\_\_\_\_

Submitted By: \_\_\_\_\_