

# 1230 ERV

## ENERGY RECOVERY VENTILATOR



### ENGINEERING DATA:

#### TOTAL RECOVERY CORE

The cross-flow energy recovery core transfers heat and water vapor between the two air streams. It is easily removed for cleaning or service.

#### MOTORS

Two PSC, 3 speed double shafted, 120 VAC, 9.4 A each (18.8 A total on high speed). HP - 1/2, 1625 RPM. MCA: 23.5, MOP: 30. Total on high speed: 2256 watts.

#### FILTERS

2 in. pleated MERV8 filters in supply and exhaust air streams.

#### BLOWERS

Slide in / out easily of unit. Centrifugal type rated at 1200 CFM (566 L/s) free air delivery. Each air stream has one double shafted motor driving a centrifugal blower.

#### CONNECTION DUCT SIZES

Four 20 in. x 8 in. (508 mm x 200 mm).

#### MOUNTING

Unit to be set on support brackets hung by threaded rod type apparatus (brackets and rod not provided).

#### CABINET

Unit has front and back access doors and electrical panel can be switched to either side giving installer flexibility in duct connection. 20 gauge prepainted galvanized steel (G60) for superior corrosion resistance. Insulated with foil faced insulation where required to prevent exterior condensation.

#### ELECTRONICS

Integrated microprocessor circuit board. Built-in interlock contacts. Optional remote speed control.

#### FROST PREVENTION

Temperature sensor activated, periodically shuts down supply motor. Drains not required.

### CONTROLS

#### 99-BC04 - Lifebreath Ventilation Control

2 speed fan setting (Low/High). 2 modes of operation: Ventilation, 20/40. Compatible with 99-DET02 Wireless Timers. 3 wire connection: 20 gauge wire (minimum).



### TIMER OPTIONS

#### 99-DET01 - Lifebreath 20/40/60 Minute Timer

Initiates high speed ventilation for 20, 40 or 60 minutes. 3 wire connection.

#### 99-DET02 - Wireless Lifebreath 20/40/60 Minute Timer

Initiates high speed ventilation for 20, 40 or 60 minutes. Wirelessly connects to main control for ease of installation. 40' approximate range. **Exclusive to Lifebreath.**

#### 99-RX02 - Wireless Lifebreath Repeater

Extends range of 99-DET02 Wireless Timers. Plugs into 120V power outlet. Wirelessly connects to main control and 99-DET02. Install at halfway point between timer and main wall control if timer is out of range.

# 1230 ERV

## ENERGY RECOVERY VENTILATOR



Airflows (Each Air Stream)

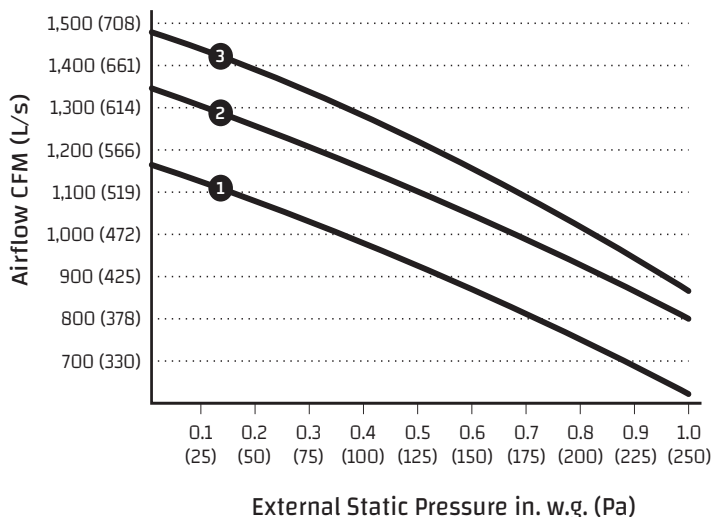

Total Effectiveness

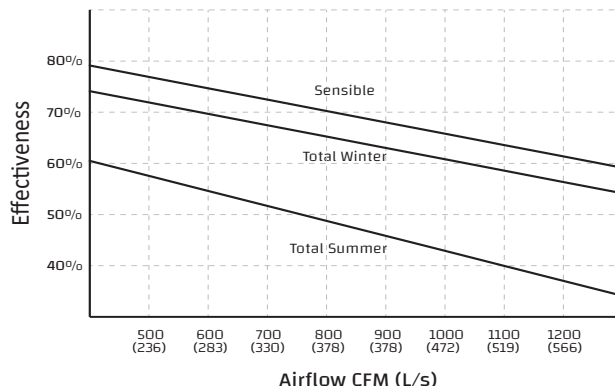

AHRI 1060 Certified Core:  
Contains three 68-280



**NOTE:**  
The 1230ERV model may easily be reversed in the field. Service clearance is 30 in. (760 mm) from front access doors.

**WEIGHT:**  
285 LBS (130 KG)

**SHIPPING WEIGHT:**  
335 LBS (152 KG)

### DIMENSIONS

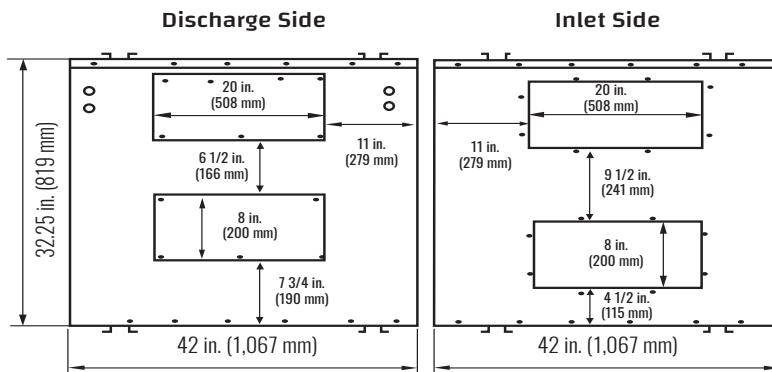
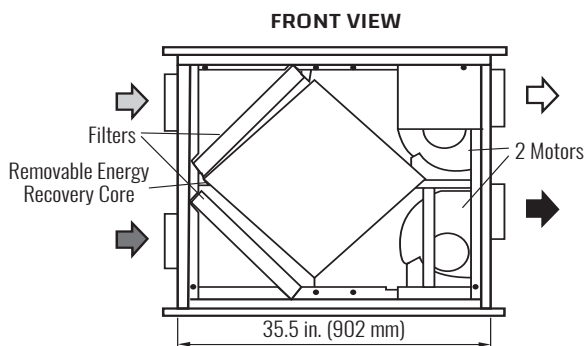

- ↔ Stale Air to Outside
- ➔ Fresh Air from Outside
- ➔ Stale Air from Inside
- ➔ Fresh Air to Inside

Date: \_\_\_\_\_

Tag: \_\_\_\_\_

Project: \_\_\_\_\_ Qty: \_\_\_\_\_

Engineer: \_\_\_\_\_

Control: \_\_\_\_\_

Contractor: \_\_\_\_\_

Supplier: \_\_\_\_\_

Quote #: \_\_\_\_\_

Submitted By: \_\_\_\_\_

Timer: \_\_\_\_\_ Timer Qty: \_\_\_\_\_

**WARRANTY**  
Units carry a 10 year warranty on the ERV core and a 2 year replacement parts warranty.

All units conform to CSA and UL standards



www.lifebreath.com