

170 ERVD

ENERGY RECOVERY VENTILATOR



SUPERIOR PERFORMANCE TOP CHOICE ERV

The compact design of the 170 ERVD model combined with superior performance, makes Lifebreath the top choice. Three units in one by the way of the high-speed select feature allows for maximum control of airflow and comfort. Features a top port design, door port balancing, 6 in. duct connections and our ERV core.

- HVI Cold weather certified ERV
- Enthalpy energy exchange core
- Top-port design with built-in balancing dampers
- Intelligent defrost damper motor
 - Smart damper with integrated circuit board
 - Energy-efficient DC motor
 - Power-saving standby mode
 - Integrated Ice Breaker technology
- Automatic frost prevention with optional drains

ENGINEERING DATA:

TOTAL RECOVERY CORE

Cross-flow energy recover core transfers heat and water vapor between two airstreams. Easily removed for cleaning or service.

MOTORS AND BLOWERS

Each airstream has an independent motorized impeller with multiple fan speed operation.

FILTERS

Washable MERV-6 air filters in exhaust and supply airstreams. Upgrade to MERV-13 option available.

MOUNTING

Adjustable hanging straps supplied.

DEFROST

Recirculating damper defrost system.

CASE

20 gauge prepainted galvanized steel for superior corrosion resistance, insulated to prevent exterior condensation.

INSTALLER SELECTABLE HIGH SPEED SETTINGS

Adjustable DIP switches are located on the circuit board, Hi3 is the factory setting. Refer to the installation manual for the adjustment instructions.

ELECTRONICS

Main control can be wall mounted in a central location. 3 wire 20 gauge (min.) 100 ft. length (max.)

OPTIONAL ACCESSORIES:

Dual Hood
99-190
99-194



Weather Hood
99-185
99-186
99-187



TechGrille
99-EAG4
99-EAG5
99-EAG6
99-EAG8



Terminator Fitting
99-TM4
99-TM5
99-TM6



LIFEBREATH DXPL-O3 FEATURES

5 speed fan operation on each mode	✓
2 speed fan operation (Low/High)	✓
Continuous low speed fan operation	✓
Humidity control through adjustable Dehumidistat	✓
Large digital LCD screen	✓
Continuous Ventilation	✓
Continuous Recirculation	✓
20 ON/40 OFF	✓
10 ON/50 OFF	✓
20 ON/40 Recirculation	✓
20/40/60 min. High speed override button	✓
Compatible with 99-DET02 Wireless Timer	✓
3 wire connection	✓

TIMER OPTIONS

99-DET01 - 20/40/60 Minute Timer

Initiates high speed ventilation for 20, 40 or 60 minutes. 3 wire connection.

99-DET02 - 20/40/60 Minute Timer

Initiates high speed ventilation for 20, 40 or 60 minutes. Wirelessly connects to main control for ease of installation. 40 ft approximate range.

99-RX02 - Wireless Repeater

Extends range of 99-DET02 Wireless Timers. Plugs into 120V power outlet. Wirelessly connects to main control and 99-DET02. Install at halfway point between timer and main wall control if timer is out of range.



99-DXPLO3



99-DET01



99-DET02



99-RX02

*Recirculation features not available on fan defrost models.

170 ERVD

ENERGY RECOVERY VENTILATOR



PERFORMANCE

IN. W.G. (PA)	0.2 (50) CFM (L/s)	0.3 (75) CFM (L/s)	0.4 (100) CFM (L/s)	0.5 (125) CFM (L/s)	0.6 (150) CFM (L/s)	0.7 (175) CFM (L/s)	0.8 (200) CFM (L/s)	0.9 (225) CFM (L/s)
Net Supply Airflow	182 (86)	172 (81)	161 (76)	150 (71)	140 (66)	127 (60)	117 (55)	104 (49)
Gross Supply Airflow	191 (90)	180 (85)	167 (79)	157 (74)	146 (69)	133 (63)	121 (57)	108 (51)
Gross Exhaust Airflow	180 (85)	170 (80)	159 (75)	148 (70)	138 (65)	125 (59)	114 (54)	104 (49)

ELECTRICAL SPECIFICATIONS	
VAC @ 60Hz	120
*Watts / Low Speed	60
*Watts / High Speed	110
*Amp Rating	1.4

* Sensible Effectiveness (ASE) @ 65 CFM (31 L/s)	32°F (0°C)	89%
Sensible Efficiency (SRE) @ 66 CFM (31 L/s)	32°F (0°C)	75%
Total Efficiency (TRE) @ 64 CFM (30 L/s)	95°F (35°C)	51%
Sensible Efficiency (SRE) @ 68 CFM (32 L/s)	-13°F (-25°C)	62%

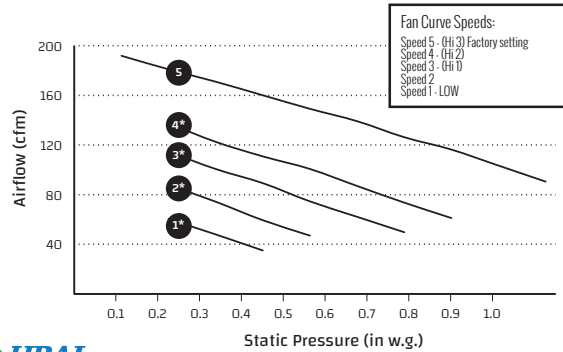

* Not an HVI certified data point



WEIGHT:
57 LBS (25.8 KG)

SHIPPING WEIGHT:
67 LBS (30 KG)

NOTE:
Front clearance of 25 in. (635 mm) is recommended for servicing unit. All ducts use 6 in. (152 mm) oval collars, balancing dampers are located on all collars.

MERV 13 Upgrade: 65-192-6R

DIMENSIONS

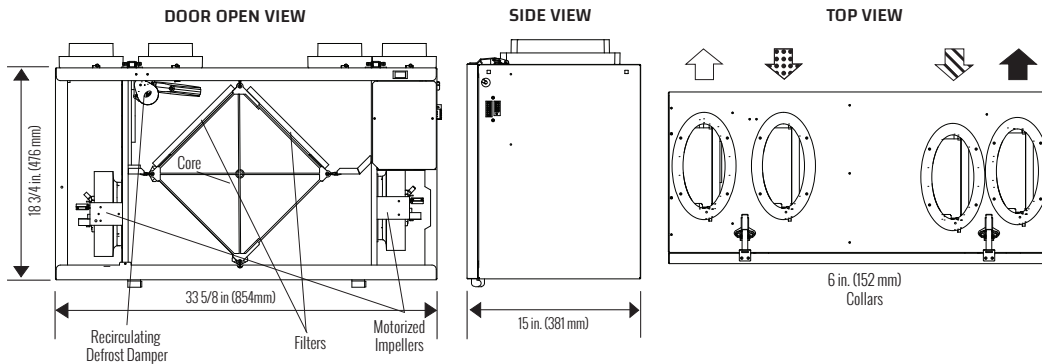

Airflow:

- Stale Air to Outside
- Fresh Air from Outside
- Stale Air from Inside
- Fresh Air to Inside

Date: _____

Contractor: _____

Tag: _____

Supplier: _____

Project: _____ Qty: _____

Quote #: _____

Engineer: _____

Submitted By: _____

Control: _____

Timer: _____ Timer Qty: _____

WARRANTY

Units carry a 5 year warranty on the enthalpic (ERV) core and a 5 year replacement parts warranty.

All units conform to CSA and UL standards



www.lifebreath.com