

# METRO 120F-ECM

## HEAT RECOVERY VENTILATOR



### BRINGING COMPACT TO A WHOLE NEW LEVEL

- Designed for high-rise condos, apartments and townhomes with limited mechanical space
- Low profile, fits in bulkhead and drop ceilings, slim height 9.75 in. (plus 1 in. drain cup)
- 50-130 CFM operational range
- 3 High speed selections
- Brackets included for easy install
- Aluminum HEX Core for superior heat transfer
- Fan Defrost
- Multi-positional drain
- Removable motor and electronic assembly for easy maintenance and service
- Swing open e-box cover for quick access to circuit board and DIP switches
- Convenient hinged door - no screws

### ENGINEERING DATA:

**THERMALLY CONDUCTIVE, PATENTED ALUMINUM HEX CORE**  
Counter-flow heat recovery core transfers heat between two airstreams. It is easily removed for cleaning or service.

**MOTORS AND BLOWERS**  
Each airstream has an independent centrifugal high efficiency ECM blower with multiple fan speed operation.

**FILTERS**  
Washable MERV-6 air filters in exhaust and supply airstreams. Upgrade to MERV-13 option available.

**MOUNTING**  
Mounting brackets supplied.

**DEFROST**  
Supply air shuts off to defrost core with warm exhaust air at high speed.

**CASE**  
20 gauge prepainted galvanized steel for superior corrosion resistance, insulated to prevent exterior condensation.

**INSTALLER SELECTABLE HIGH SPEED SETTINGS**  
Adjustable DIP switches are located on the circuit board, Hi3 is the factory setting. Refer to the installation manual for adjustment instructions.

**ELECTRONICS**  
Main control can be wall mounted in a central location. 3 wire 20 gauge (min.) 100 ft. length (max.)

**OPTIONAL FEATURES**  
Hardwired configurations available.

See manual for details.

### OPTIONAL ACCESSORIES:

**Dual Hood**  
99-190  
99-194



**Weather Hood**  
99-185  
99-186  
99-187



**TechGrille**  
99-EAG4  
99-EAG5  
99-EAG6  
99-EAG8



**Terminator Fitting**  
99-TM4  
99-TM5  
99-TM6



### LIFEBREATH DXPL-O3 FEATURES

5 speed fan operation on each mode	✓
2 speed fan operation (Low/High)	✓
Continuous low speed fan operation	✓
Humidity control through adjustable Dehumidistat	✓
Large digital LCD screen	✓
Continuous Ventilation	✓
Continuous Recirculation	✓
20 ON/40 OFF	✓
10 ON/50 OFF	✓
20 ON/40 Recirculation	✓
20/40/60 min. High speed override button	✓
Compatible with 99-DET02 Wireless Timer	✓
3 wire connection	✓

### TIMER OPTIONS

#### 99-DET01 - 20/40/60 Minute Timer

Initiates high speed ventilation for 20, 40 or 60 minutes. 3 wire connection.

#### 99-DET02 - 20/40/60 Minute Timer

Initiates high speed ventilation for 20, 40 or 60 minutes. Wirelessly connects to main control for ease of installation. 40 ft approximate range.

#### 99-RX02 - Wireless Repeater

Extends range of 99-DET02 Wireless Timers. Plugs into 120V power outlet. Wirelessly connects to main control and 99-DET02. Install at halfway point between timer and main wall control if timer is out of range.



99-DXPLO3



99-DET01



99-DET02



99-RX02

\*Recirculation features not available on fan defrost models.

# METRO 120F-ECM

## HEAT RECOVERY VENTILATOR



### PERFORMANCE

IN. W.G. (PA)	0.2 (50) CFM (L/s)	0.3 (75) CFM (L/s)	0.4 (100) CFM (L/s)	0.5 (125) CFM (L/s)	0.6 (150) CFM (L/s)	0.7 (175) CFM (L/s)	0.8 (200) CFM (L/s)	0.9 (225) CFM (L/s)
Net Supply Airflow	123 (58)	117 (55)	110 (52)	102 (48)	92 (43)	81 (38)	67 (32)	51 (24)
Gross Supply Airflow	124 (58)	118 (55)	111 (52)	103 (48)	93 (44)	81 (38)	68 (32)	52 (24)
Gross Exhaust Airflow	113 (53)	106 (50)	100 (47)	92 (43)	84 (39)	73 (34)	61 (28)	46 (21)

ELECTRICAL SPECIFICATIONS	
VAC @ 60Hz	120
Watts @ 49 CFM (23L/s)	18
*Amp Rating	1.4

*Sensible Effectiveness (ASE) @ 49 CFM (23 L/s)	32°F (0°C)	78%
Sensible Efficiency (SRE) @ 49 CFM (23 L/s)	32°F (0°C)	71%

\* Not an HVI certified data point

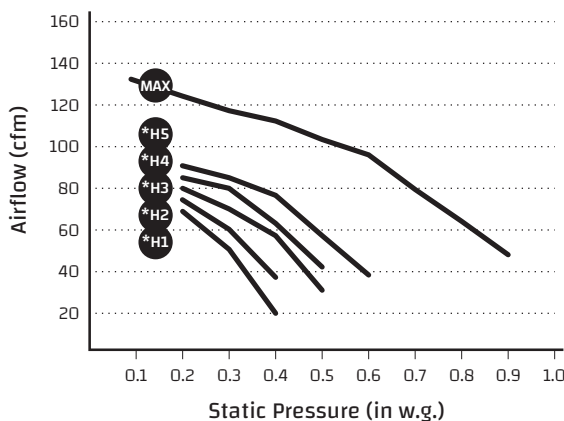

WEIGHT:  
**34 LBS (15.5 KG)**

SHIPPING WEIGHT:  
**36 LBS (16 KG)**

**NOTE:**  
Front clearance of 25 in. (635 mm)  
is recommended for servicing unit. All  
ducts use 5 in. (125 mm) round collars.

MERV 13 Upgrade: 65-195-6R

### DIMENSIONS

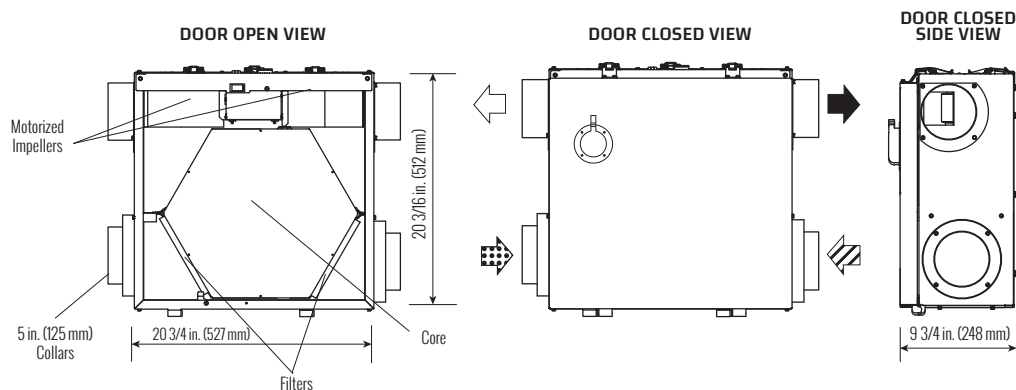

#### Standard Airflow:

- Stale Air to Outside
- Fresh Air from Outside
- Stale Air from Inside
- Fresh Air to Inside

Date: \_\_\_\_\_

Contractor: \_\_\_\_\_

Tag: \_\_\_\_\_

Supplier: \_\_\_\_\_

Project: \_\_\_\_\_ Qty: \_\_\_\_\_

Quote #: \_\_\_\_\_

Engineer: \_\_\_\_\_

Submitted By: \_\_\_\_\_

Control: \_\_\_\_\_

Timer: \_\_\_\_\_ Timer Qty: \_\_\_\_\_

#### WARRANTY

Units carry a lifetime warranty on the HRV core and a 5 year replacement parts warranty.

All units conform to CSA and UL standards