

# 2000EFD

## HEAT RECOVERY VENTILATOR



### ENGINEERING DATA:

#### AIRFLOW

2000 CFM (940 L/s) at 1.0 in. w.g. ESP.

#### PERFORMANCE

65% effective at 2000 CFM (940 L/s).

#### CORES

Eight patented aluminum heat recovery cores arranged for efficient cross-flow ventilation.

#### BLOWERS

Two belt drive centrifugal blowers with adjustable pulleys, one per air stream.

#### FILTERS

Two 16 in. x 25 in. x 2 in. (406 mm x 635 mm x 50 mm) pleated filters in each air stream. MERV 8 efficiency.

#### CONNECTION DUCT SIZES

Two 20 in. x 19 in. (508 mm x 482 mm) hoods included with washable screens. Two 25 in. x 16 in. (635 mm x 406 mm) connections to and from building under cabinet.

#### CABINET

20 gauge powder coated steel for superior corrosion resistance. Unit includes metal lined sides and roof panels with 1 in. fiberglass insulation.

#### DRAIN

Two powder coated galvanized steel drain pans with 1/2 in. (12 mm) O.D. drain connections.

#### MOUNTING

Rooftop mounted on optional curb (Part No. 53-2007).

#### ELECTRONICS

Integrated microprocessor board.

#### DEFROST

Factory set defrost time. Supply motor is shut off while exhaust air defrosts core.

### VOLTAGE OPTIONS:

VOLTAGE	PHASE	MOTOR	AMPS	MCA	MOP	SKU
208	1	Two ODP, 2.0 hp, single shaft, single speed	18.2	26	30	200-2000EFD-208SP*
240	1	Two ODP, 2.0 hp, single shaft, single speed	18.2	20.25	30	200-2000EFD-240SP
208	3	Two ODP, 2.0 hp, single shaft, single speed	5.9	14.75	20	200-2000EFD-2083P*
460	3	Two TEFC, 1.5 hp, single shaft, single speed	5.2	6.5	8	200-2000EFD-4603P*
575	3	Two TEFC, 1.5 hp, single shaft, single speed	4	4.5	6	200-2000EFD-5753P*

\*Special Inspection is required

### CONTROLS

#### 99-BC02 - Lifebreath Ventilation Control

Humidity control through adjustable Dehumidistat. Compatible with 99-DET02 Wireless Timers. 3 wire connection; 20 gauge wire (minimum).

### TIMER OPTIONS

#### 99-DET01 - Lifebreath 20/40/60 Minute Timer

Initiates high speed ventilation for 20, 40 or 60 minutes. 3 wire connection.

#### 99-DET02 - Wireless Lifebreath 20/40/60 Minute Timer

Initiates high speed ventilation for 20, 40 or 60 minutes. Wirelessly connects to main control for ease of installation. 40' approximate range. **Exclusive to Lifebreath.**

#### 99-RX02 - Wireless Lifebreath Repeater

Extends range of 99-DET02 Wireless Timers. Plugs into 120V power outlet. Wirelessly connects to main control and 99-DET02. Install at halfway point between timer and main wall control if timer is out of range.



# 2000EFD

## HEAT RECOVERY VENTILATOR



### Airflow Performance

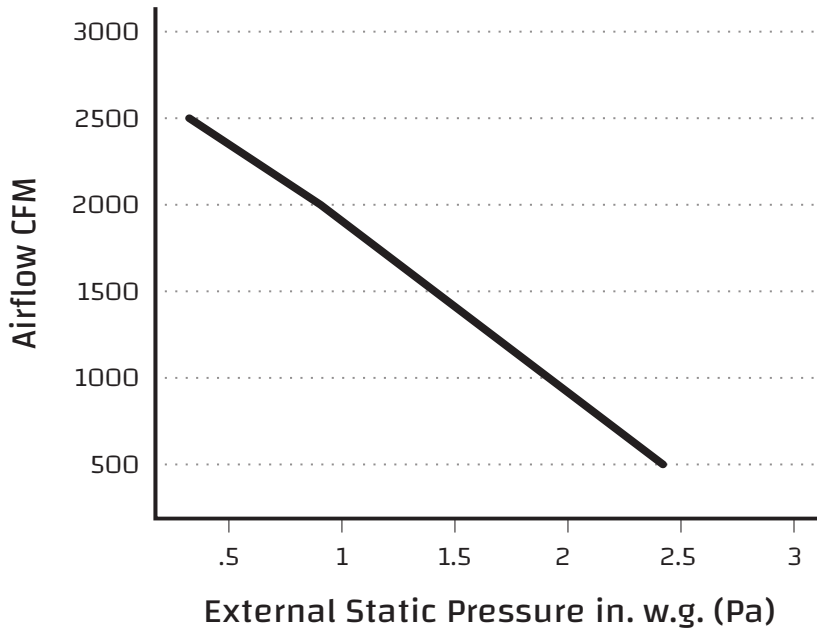

**ISO  
9001  
REGISTERED**

**WEIGHT:**  
770 LBS (350 KG)

**SHIPPING WEIGHT:**  
910 LBS (410 KG)

**NOTE:**  
Service clearance is 30 in. All specifications are subject to change without notice.

### DIMENSIONS

#### Airflow:

- ⇨ Stale Air to Outside
- ⇨ Fresh Air from Outside
- ⇨ Stale Air from Inside
- ⇨ Fresh Air to Inside

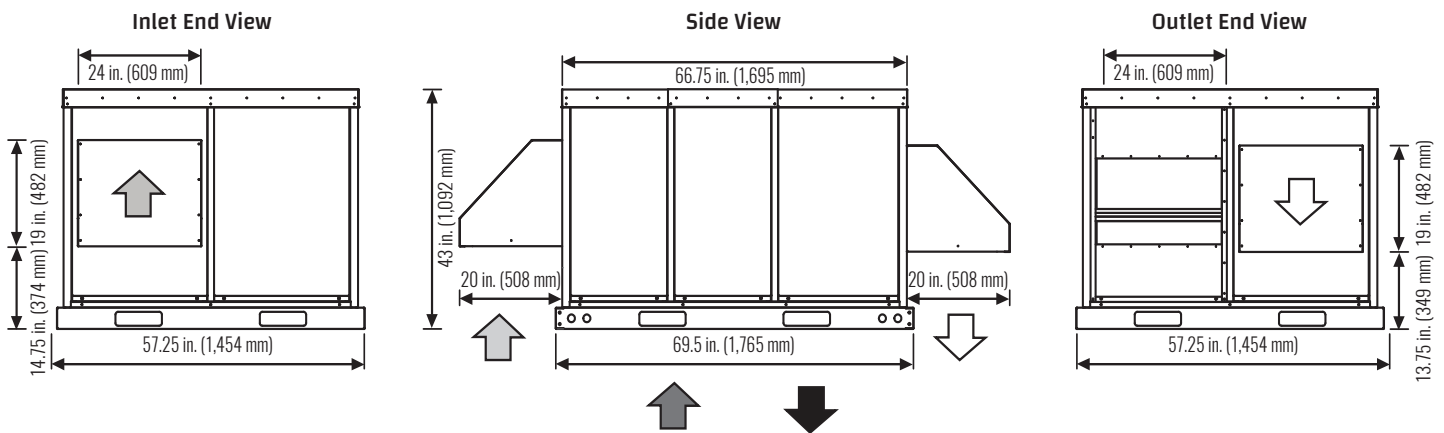

Date: \_\_\_\_\_ Contractor: \_\_\_\_\_

Tag: \_\_\_\_\_ Supplier: \_\_\_\_\_

Project: \_\_\_\_\_ Qty: \_\_\_\_\_ Quote #: \_\_\_\_\_

Engineer: \_\_\_\_\_ Submitted By: \_\_\_\_\_

Control: \_\_\_\_\_ Timer: \_\_\_\_\_ Timer Qty: \_\_\_\_\_

#### WARRANTY

Units carry a 15 year warranty on the HRV core and a 2 year replacement parts warranty.

All units conform to CSA and UL standards



www.lifebreath.com