

# 2000IFD

## HEAT RECOVERY VENTILATOR



### ENGINEERING DATA:

#### AIRFLOW

2000 CFM (940 L/s) at 1.0 in. w.g. ESP.

#### PERFORMANCE

65% effective at 2000 CFM (940 L/s).

#### CORES

Eight patented aluminum heat recovery cores arranged for efficient cross-flow ventilation.

#### BLOWERS

Two belt drive centrifugal blowers with adjustable pulleys, one per airstream.

#### FILTERS

Two 16 in. x 25 in. x 2 in. (406 mm x 635 mm x 50 mm) pleated filters in each airstream. MERV 8 efficiency.

#### CONNECTION DUCT SIZES

Four 18 in. x 22 in. (457 mm x 558 mm).

### VOLTAGE OPTIONS:

VOLTAGE	PHASE	MOTOR	AMPS	MCA	MOP	SKU
208	1	Two ODP, 2.0 hp, single shaft, single speed	18.2	26	30	200-2000IFD-208SP
240	1	Two ODP, 2.0 hp, single shaft, single speed	18	20.25	30	200-2000IFD-240SP
208	3	Two ODP, 2.0 hp, single shaft, single speed	5.9	14.75	20	200-2000IFD-2083P
460	3	Two TEFC, 1.5 hp, single shaft, single speed	5.2	6.5	8	200-2000IFD-4603P
575	3	Two TEFC, 1.5 hp, single shaft, single speed	4	4.5	6	200-2000IFD-5753P

### CONTROLS

#### 99-BC02 - Lifebreath Ventilation Control

Humidity control through adjustable Dehumidistat. Compatible with 99-DET02 Wireless Timers. 3 wire connection: 20 gauge wire (minimum).

### TIMER OPTIONS

#### 99-DET01 - Lifebreath 20/40/60 Minute Timer

Initiates high speed ventilation for 20, 40 or 60 minutes. 3 wire connection.

#### 99-DET02 - Wireless Lifebreath 20/40/60 Minute Timer

Initiates high speed ventilation for 20, 40 or 60 minutes. Wirelessly connects to main control for ease of installation. 40' approximate range. **Exclusive to Lifebreath.**

#### 99-RX02 - Wireless Lifebreath Repeater

Extends range of 99-DET02 Wireless Timers. Plugs into 120V power outlet. Wirelessly connects to main control and 99-DET02. Install at halfway point between timer and main wall control if timer is out of range.

# 2000IFD

## HEAT RECOVERY VENTILATOR



### Airflow Performance

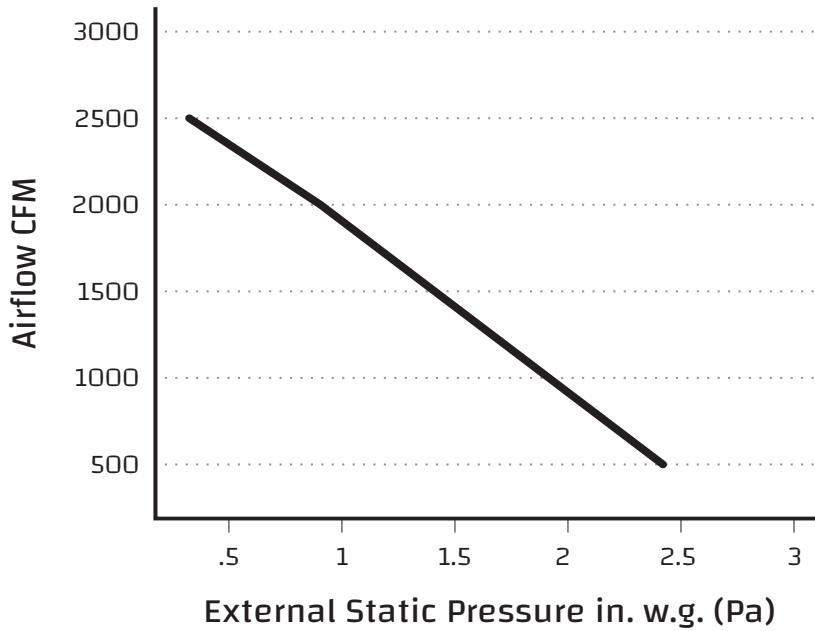

**ISO  
9001  
REGISTERED**

**WEIGHT:**  
740 LBS (330 KG)

**SHIPPING WEIGHT:**  
870 LBS (390 KG)

**NOTE:**  
Service clearance is 30 in. All specifications are subject to change without notice.

### DIMENSIONS

#### Airflow:

- Stale Air to Outside
- Fresh Air from Outside
- Stale Air from Inside
- Fresh Air to Inside

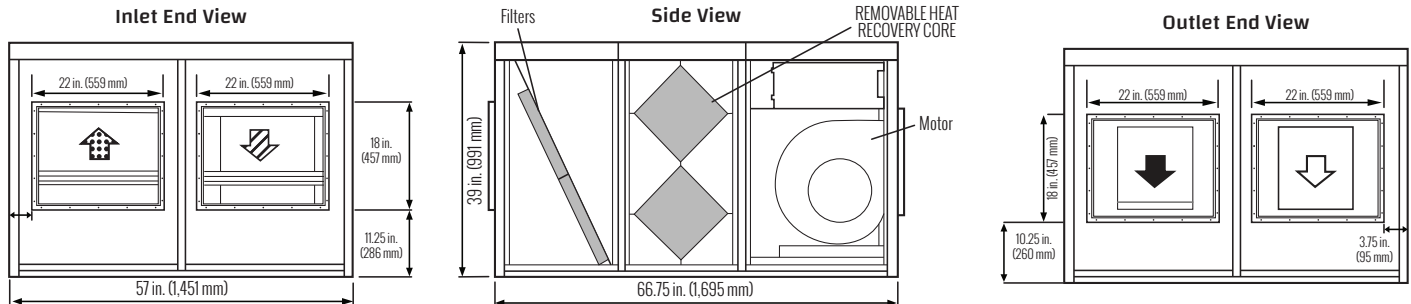

Date: \_\_\_\_\_ Contractor: \_\_\_\_\_

Tag: \_\_\_\_\_ Supplier: \_\_\_\_\_

Project: \_\_\_\_\_ Qty: \_\_\_\_\_ Quote #: \_\_\_\_\_

Engineer: \_\_\_\_\_ Submitted By: \_\_\_\_\_

Control: \_\_\_\_\_ Timer: \_\_\_\_\_ Timer Qty: \_\_\_\_\_

#### WARRANTY

Units carry a 15 year warranty on the HRV core and a 2 year replacement parts warranty.

All units conform to CSA and UL standards



www.lifebreath.com