

267MAX ERV-FID

ENERGY RECOVERY VENTILATOR



ENGINEERING DATA:

AUTO BALANCE

DXPLO3 control allows airflow to be selected for both supply and exhaust air streams. Live air pressure measurements enable automatic and continuous adjustment of fan speeds to ensure constant user selected airflow.

FAULT INDICATION DISPLAY (FID)

Title 24 Compliant. A FID enabled HRV or ERV is capable of displaying error codes for certain types of faults which impact operation of the system.

ENERGY RECOVERY CORE

Cross-flow energy recovery core transfers heat and water vapor between two airstreams. Easily removed for cleaning or service.

MOTORS AND BLOWERS

Each airstream has an independent EC motorized impeller with multiple fan speed operation.

FILTERS

Washable MERV-6 air filters in exhaust and supply airstreams. Upgrade to MERV-13 option available.

MOUNTING

Adjustable hanging straps supplied.

DEFROST

Temperature sensor activated recirculation damper defrost. Intelligent energy-efficient DC motorized damper with integrated Ice Breaker technology.

CASE

20 gauge prepainted galvanized steel for superior corrosion resistance, insulated to prevent exterior condensation.

See manual for details.

OPTIONAL ACCESSORIES:

Weather Hood

99-185
99-186
99-187



TechGrille

99-EAG4
99-EAG5
99-EAG6
99-EAG8



Terminator Fitting

99-TM4
99-TM5
99-TM6



LIFEBREATH DXPL-O3 FEATURES

5 speed fan operation on each mode	✓
2 speed fan operation (Low/High)	✓
Continuous low speed fan operation	✓
Humidity control through adjustable Dehumidistat	✓
Large digital LCD screen	✓
Continuous Ventilation	✓
Continuous Recirculation	✓
20 ON/40 OFF	✓
10 ON/50 OFF	✓
20 ON/40 Recirculation	✓
20/40/60 min. High speed override button	✓
Compatible with 99-DET02 Wireless Timer	✓
3 wire connection	✓
Auto Balance	✓

TIMER OPTIONS

99-DET01 - 20/40/60 Minute Timer

Initiates high speed ventilation for 20, 40 or 60 minutes. 3 wire connection.

99-DET02 - 20/40/60 Minute Timer

Initiates high speed ventilation for 20, 40 or 60 minutes. Wirelessly connects to main control for ease of installation. 40 ft approximate range.

99-RX02 - Wireless Repeater

Extends range of 99-DET02 Wireless Timers. Plugs into 120V power outlet. Wirelessly connects to main control and 99-DET02. Install at halfway point between timer and main wall control if timer is out of range.



99-DXPLO3



99-DET01



99-DET02



99-RX02

*Recirculation features not available on fan defrost models.

267MAX ERV-FID - 0224

LIFEBREATH
Indoor Air Systems

www.lifebreath.com

267MAX ERV-FID

ENERGY RECOVERY VENTILATOR



PERFORMANCE

IN. W.G. (PA)	0.2 (50) CFM (L/s)	0.3 (75) CFM (L/s)	0.4 (100) CFM (L/s)	0.5 (125) CFM (L/s)	0.6 (150) CFM (L/s)	0.7 (175) CFM (L/s)	0.8 (200) CFM (L/s)	0.9 (225) CFM (L/s)
Net Supply Airflow	286 (135)	278 (131)	271 (128)	263 (124)	254 (120)	246 (116)	237 (112)	229 (108)
Gross Supply Airflow	290 (137)	282 (133)	273 (129)	265 (125)	259 (122)	250 (118)	239 (113)	231 (109)
Gross Exhaust Airflow	284 (134)	278 (131)	271 (128)	263 (124)	256 (121)	248 (117)	239 (113)	231 (109)

ELECTRICAL SPECIFICATIONS	
VAC @ 60Hz	120
Watts @ 64 CFM (30L/s)	30
*Amp Rating	4.5

* Sensible Effectiveness (ASE) @ 64 CFM (30 L/s)	32°F (0°C)	85%
Sensible Efficiency (SRE) @ 64 CFM (30 L/s)	32°F (0°C)	77%
*Total Efficiency (TRE) @ 64 CFM (30 L/s)	95°F (35°C)	49%
Sensible Efficiency (SRE) @ 53 CFM (25 L/s)	-13°F (-25°C)	56%

* Not an HVI certified data point

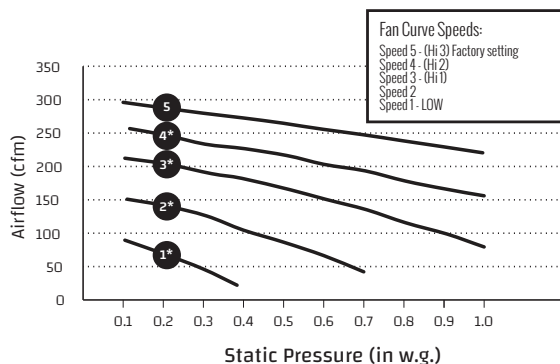

WEIGHT:
57 LBS (25.8 KG)

SHIPPING WEIGHT:
67 LBS (30 KG)

NOTE:
Front clearance of 25 in. (635 mm) is recommended for servicing unit. All ducts use 6 in. (152 mm) oval collars, balancing dampers are located on all collars.

MERV 13 Upgrade: 65-192-6R



DIMENSIONS

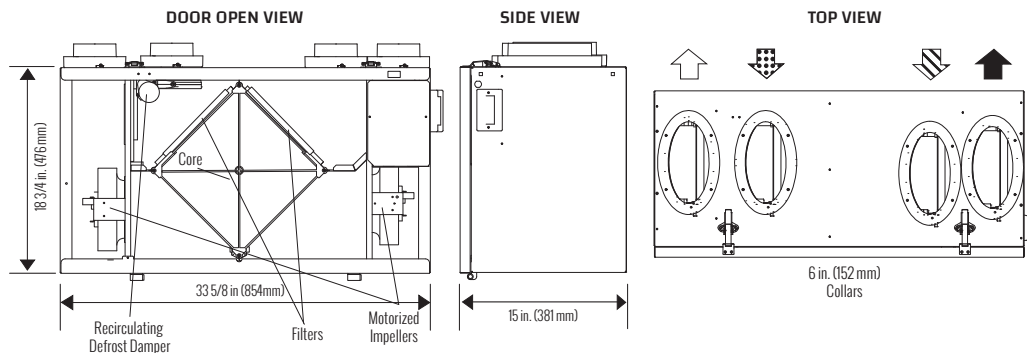

Airflow:

- ↶ Stale Air to Outside
- ↷ Fresh Air from Outside
- ↶ Stale Air from Inside
- ↷ Fresh Air to Inside

Date: _____

Contractor: _____

Tag: _____

Supplier: _____

Project: _____ Qty: _____

Quote #: _____

Engineer: _____

Submitted By: _____

Control: _____

Timer: _____ Timer Qty: _____

WARRANTY

Units carry a 5 year warranty on the enthalpic (ERV) core and a 5 year replacement parts warranty.

All units conform to CSA and UL standards

