



**HEAT RECOVERY VENTILATORS &  
ENERGY RECOVERY VENTILATORS**

# IOM

**HRVs:**

**METRO 120F  
METRO 120F-ECM\*  
METRO 120D  
METRO 120D-ECM**

**ERVs:**

**MAX XTR\*  
METRO 120 ERV  
METRO 120 ERV-ECM\*  
METRO 120ERV D\*  
METRO 120 ERVD-ECM\*  
METRO XTR  
MAX XTR PLUS**

\* - Denotes all configurations and variations of each model are included in this manual

**Installation, Operation  
and Maintenance Manual**

## Installation, Operation and Maintenance Manual

Please read and save these instructions for future reference. Read carefully before attempting to assemble, install, operate or maintain the product described. Protect yourself and others by observing all safety information. Failure to comply with these instructions will result in voiding of the product warranty and may result in personal injury and/or property damage.

### Table of Contents

Shipping and Packing List.....	3
Terms and Definitions.....	3
Application.....	3
Required Tools and Materials.....	3
Serial Number Nomenclature Breakdown.....	4
Specifications.....	5-8
Optional Fan Curve Speeds.....	9-10
Dimensional Drawings.....	11-12
Defrost Overview.....	14
Required Ventilation.....	14
How the Dehumidistat Works.....	15
BCO2 Basic Control.....	16
BCO3 Basic Control.....	17
BCO4 Basic Control.....	17
DXPLO3 Deluxe Control.....	18
DETO1 Wired Timer.....	19
DETO2 Wireless Timer.....	19
RXO2 Repeater.....	19
Overview of Installation Methods.....	20
Installation Methods - Simplified (Return/Return).....	21
Installation Methods - Partially Dedicated.....	22
Installation Methods - Fully Dedicated.....	23
Unit Installation Location and Restrictions.....	24
Mounting the Unit.....	25
Installing the Drain Connection.....	25
Directions to Field Mirror the METRO-120ERV-ECM & MAX XTR PLUS.....	26
Grilles.....	27
Grille Fittings.....	28
Lifebreath Weatherhoods.....	29
Dual Hood Kit.....	30
Terminal Blocks.....	31
Installation and Operation of DETO2 Wireless Timer.....	32
Installation and Pairing of RXO2 Repeater.....	33
Installation of DETO1 Timer.....	34
Installation of Third Party Mechanical Timers.....	34
Interlocking HRV/ERV to Air Handler/Furnace Blower.....	34
Electrical Connections.....	35
Unit Wiring Diagrams.....	36-37
Unit Dip Switch Orientation.....	38-40
Balancing the Airflows.....	41
Manual Balancing.....	41-42
Balancing The Airflows - Collar Port Method.....	43-44
Auto Balancing.....	45
Fault Indicator Display Board (FID).....	46
Troubleshooting.....	47
Homeowner Maintenance Information.....	48-49

# Shipping and Packing List

Package 1 of 1 contains:

1 - Assembled ventilator

1 - Accessories Bag assembly contains the following:

**Table 1. Accessories Bag Assembly Contents**

TYPE	UNIT NAME	CONTENTS	
ERV's	METRO 120ERV, METRO 120ERV-ECM, METRO 120ERVD, & 120ERVD-ECM	1x Ventilation Label 4x Mounting Brackets	8x Screws
ERV's	MAX XTR, METRO XTR	1x Ventilation Label 4x Mounting Brackets	8x Screws 1x Terminal Block Connection
HRV's	METRO 120F, METRO 120F-ECM, METRO 120D, & METRO 120D-ECM	1x Ventilation Label 4x Mounting Brackets	12x Screws 1x Cup Drain Spout
ERV's	MAX XTR PLUS	1x Ventilation Label 4x Mounting Brackets	8x Screws 1x Terminal Block Connection 1x DXPL03

## WARNING

Improper installation, adjustment, alteration, service or maintenance can cause property damage, personal injury or loss of life. Installation and service must be performed by a licensed professional HVAC installer (or equivalent) or a service agency.

## Terms and Definitions

- **ERV** - Energy Recovery Ventilator.
- **HRV** - Heat Recovery Ventilator.
- **Defrost Mode** - to ensure reliable operation during cold weather, the HRV/ERV will automatically cycle through its defrost mode as needed.
- **Dehumidistat** - a control device that senses the amount of moisture in the air and activates high-speed ventilation when the air moisture level exceeds the setpoint.
- **Reset** - whenever resetting of the HRV/ERV is required, simply unplug the power cord for 30 seconds. The Self-Test will occur when the HRV/ERV is reconnected.
- **Self-Test** - each time the HRV/ERV is powered/energized, the self-test function will automatically initiate. During the self-test, the HRV/ERV will cycle through all the speeds available (1 – 5), test the damper motor operation, and will default back to the previous operational mode and speed selection. Total self-test duration is approximately 90 seconds.
- **Standby Mode** - the HRV/ERV is powered/energized and waiting for fan operation to be initiated. For example, the HRV/ERV is set to Continuous Ventilation Operation Mode at speed 0.
- **Thermistor** - This is the temperature sensor that measures electrical resistance as outdoor temperatures fluctuate.
- **HVI** - Home Ventilating Institute.
- **HRAI** - Heating Refrigeration Air Conditioning Institute.

## Application

This equipment is designed to provide fresh air while staleing an equal amount of stale air. The HRV units transfer sensible (temperature) incoming fresh air and staleing stale air. The ERV units transfer both sensible (temperature) and latent (moisture) between incoming fresh air and exhausting stale air.

## Required Tools and Materials

Field Provided Material

- Low voltage control wire
- Mastic tape
- 1/2" I.D. Drain hose
- Caulking material
- Aluminum foil duct tape
- Zip ties (duct)
- Flexible or rigid, insulated or non-insulated ducts - class II rated zip ties

## CAUTION

Potential equipment malfunction or damage. May require repairs and/or void warranty.

Do not interconnect HRV/ERV to other appliances such as Stove Vents, Clothes Dryer Vents, Central Vacuum Systems, Auxiliary Fans, etc. As with any mechanical equipment, contact with sharp sheet metal edges can result in personal injury.

Take care while handling this equipment and wear gloves and protective clothing.

# Serial Number Nomenclature Breakdown

Each Serial Number begins with a 2-character alpha code followed by an 11-digit number code.

Example Serial number:

## XA 08082312345

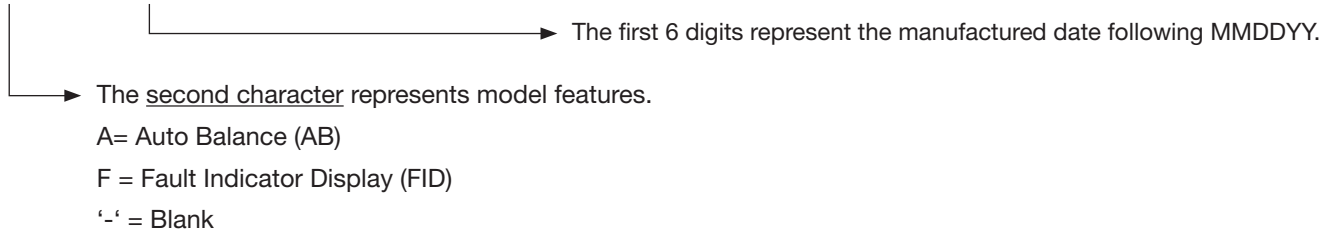

Therefore, this model would be a unit with Auto Balance features manufactured on Aug 8th, 2023.

**Note: For simplicity of this manual the models with added features will be referred to as the following**

Unit with AB features	Unit with FID features
MAX XTR METRO 120F-ECM-AB METRO 120ERV-ECM-AB MAX XTR PLUS	MAX XTR-FID METRO 120F-ECM-FID METRO 120ERV-ECM-FID
<b>Mirrored Units</b> Models ending in “-M” signify mirrored units. These are models that have the same performance as the standard model with exception of their direction of airflow. The METRO-120ERV, METRO-120ERVD and METRO-120ERVD-ECM are all offered from the factory as mirrored sku’s. The model names are METRO-120ERV-M, METRO-120ERVD-M and METRO-120ERVD-ECM-M respectively. The METRO-120ERV-ECM can be reversed in the field by the contractor. MAX XTR PLUS is field reversible with switch and TB04B with Jumper.	

# Specifications - ERV Units

**Table 2. ERV Specifications**

Specifications	Single-Core ERV Units						
Model No.	METRO 120ERV	METRO 120ERV-ECM	MAX XTR	MAX XTR PLUS	METRO 120ERVD	METRO 120ERVD-ECM	METRO XTR
Unit Weight in pounds (kg)	34 (15)	34 (15)	42 (19)	42 (19)	37 (17)	37 (17)	42 (19)
Unit Dimensions	Refer to "Dimensional Drawings" on pages 10 & 11.						
	High Speed (HVI Certified)						
Inches wg (Pa)	CFM (L/s)	CFM (L/s)	CFM (L/s)	CFM (L/s)	CFM (L/s)	CFM (L/s)	CFM (L/s)
0.1 (25)	138 (65)	131 (62)	195 (92)	195 (92)	133 (63)	131 (62)	161 (76)
0.2 (50)	133 (63)	123 (58)	186 (88)	186 (88)	129 (61)	123 (58)	150 (71)
0.3 (75)	129 (61)	117 (55)	178 (84)	178 (84)	125 (59)	117 (55)	140 (66)
0.4 (100)	125 (59)	108 (51)	170 (80)	170 (80)	123 (58)	108 (51)	127 (60)
0.5 (125)	119 (56)	97 (46)	161 (76)	161 (76)	119 (56)	97 (46)	117 (55)
0.6 (150)	114 (54)	87 (41)	153 (72)	153 (72)	122 (53)	87 (41)	106 (50)
0.7 (175)	108 (51)	74 (35)	144 (68)	144 (68)	108 (51)	74 (35)	93 (44)
0.8 (200)	102 (48)	57 (27)	136 (64)	136 (64)	102 (48)	57 (27)	81 (38)
0.9 (225)	93 (44)	40 (19)	125 (59)	125 (59)	95 (45)		68 (32)
1.0 (250)	85 (40)		117 (55)	117 (55)	87 (41)		55 (26)
Adjusted Sensible Recovery Efficiency @ 32°F (0°C)*	@ 49 CFM (23 L/s) 78%	@ 49 CFM (23 L/s) 75%	@ 64 CFM (30 L/s) 88%	@ 64 CFM (30 L/s) 88%	@ 64 CFM (30 L/s) 77%	@ 64 CFM (30 L/s) 74%	@ 64 CFM (30 L/s) 83%
Sensible Recovery Efficiency @ 32°F (0°C)*	@ 49 CFM (23 L/s) 69%	@ 49 CFM (23 L/s) 72%	@ 64 CFM (30 L/s) 84%	@ 64 CFM (30 L/s) 84%	@ 64 CFM (30 L/s) 72%	@ 64 CFM (30 L/s) 72%	@ 64 CFM (30 L/s) 77%
Adjusted Sensible Recovery Efficiency @ -13°F (-25°C)*	N/A	N/A	@ 68 CFM (32 L/s) 66%	@ 68 CFM (32 L/s) 66%	N/A	@ 57 CFM (27 L/s) 59%	@ 70 CFM (27 L/s) 66%
Sensible Recovery Efficiency @ -13°F (-25°C)*	N/A	N/A	@ 68 CFM (32 L/s) 64%	@ 68 CFM (32 L/s) 64%	@ 53 CFM (25 L/s) 54%	@ 57 CFM (27 L/s) 57%	@ 70 CFM (27 L/s) 63%
Latent Efficiency 95°F (35°C)*	@ 49 CFM (23 L/s) 44%	@ 49 CFM (23 L/s) 45%	@ 64 CFM (30 L/s) 61%	@ 64 CFM (30 L/s) 61%	@ 64 CFM (30 L/s) 38%	@ 64 CFM (30 L/s) 36%	@ 64 CFM (30 L/s) 54%
Total Efficiency 95°F (35°C)*	@ 49 CFM (23 L/s) 45%	@ 49 CFM (23 L/s) 51%	@ 64 CFM (30 L/s) 65%	@ 64 CFM (30 L/s) 65%	@ 64 CFM (30 L/s) 44%	@ 64 CFM (30 L/s) 46%	@ 64 CFM (30 L/s) 53%
*Certified by the Home Ventilating Institute (HVI) according to test procedures developed by HVI members and based on internationally recognized standards. For performance ratings at other conditions not shown, please visit the HVI website.							
Number of speeds available with BC02 basic control	2	2	2	N/A	2	2	2
Number of speeds available with BC03 basic control	1	N/A	N/A	N/A	1	N/A	1
Number of speeds available with BC04 basic control	2	N/A	N/A	N/A	2	N/A	2

# Specifications - ERV Units

**Table 2. ERV Specifications (continued)**

Specifications	Single-Core ERV Units						
	METRO 120ERV	METRO 120ERV-ECM	MAX XTR	MAX XTR PLUS	METRO 120ERVD	METRO 120ERVD-ECM	METRO XTR
Number of speeds available with DXPL03 Control	5	5	5	5	5	5	5
Ventilator Type	Energy Recovery	Energy Recovery	Energy Recovery	Energy Recovery	Energy Recovery	Energy Recovery	Energy Recovery
Energy Recovery Core	Enthalpic	Enthalpic	Enthalpic	Enthalpic	Enthalpic	Enthalpic	Enthalpic
Defrost Type	Fan	Fan	Fan	Fan	Damper	Damper	Fan
Balancing	N/A	N/A	Auto-Balance	Auto-Balance	N/A	N/A	Collar Port
Number of Ports	4	4	4	4	4	4	4
Pre-Filters Supply & Exhaust	MERV 6 or MERV 13**		MERV 8 or MERV 13	MERV 8 or MERV 13	MERV 6 or MERV 13**		
	** To be ordered separately. Comes in a set of 4 and is installed in the Fresh Side only. When a MERV 13 filter is installed for the first time, airflow will need to be balanced.						
Condensate Drain Connections: Spouts: qty. 2 (1/2" o.d.) Drain Tee: qty. 1 (1/2" o.d.)	No	No	No	No	No	No	No
Hanging Strap kit Included	No	No	No	No	No	No	No
Mounting Brackets Included	Yes	Yes	Yes	Yes	Yes	Yes	Yes
Electrical Characteristics: 120 Volts, 60 Hertz, 1 phase							
Motor type	PSC	ECM	ECM	ECM	PSC	ECM	PSC
*Fan watts @ HVI Test 32°F (0° C)	@ 49 CFM (23 L/s), 60W	@ 49 CFM (23 L/s), 22W	@ 64 CFM (30 L/s), 35W	@ 64 CFM (30 L/s), 35W	@ 64 CFM (30 L/s), 52W	@ 64 CFM (30 L/s), 26W	@ 64 CFM (30 L/s), 77W
Fan Watt Rating	160	84	130	130	160	84	104
Amp Rating	1.4	1.4	2	2	1.4	1.4	0.9
* Certified by the Home Ventilating Institute (HVI) according to test procedures developed by HVI members and based on internationally recognized standards. For performance ratings at other conditions not shown, please visit the HVI website.							

# Specifications - HRV Units

**Table 3. HRV Specifications**

Specifications	Single-Core HRV Units			
Model No.	METRO 120F	METRO 120F-ECM	METRO 120D	METRO 120D-ECM
Unit Weight in pounds (kg)	34 (15)	34 (15)	37 (17)	40 (19)
Unit Dimensions	Refer to “Dimensional Drawings” on pages 10 & 11.			
	High Speed (HVI Certified)			
Inches wg (Pa)	CFM (L/s)	CFM (L/s)	CFM (L/s)	CFM (L/s)
0.1 (25)	138 (65)	129 (61)	140 (66)	133 (63)
0.2 (50)	136 (64)	123 (58)	136 (64)	127 (60)
0.3 (75)	131 (62)	117 (55)	131 (62)	121 (57)
0.4 (100)	127 (60)	110 (52)	127 (60)	114 (54)
0.5 (125)	121 (57)	102 (48)	123 (58)	108 (51)
0.6 (150)	117 (55)	93 (44)	119 (56)	100 (47)
0.7 (175)	112 (53)	81 (38)	112 (53)	89 (42)
0.8 (200)	106 (50)	68 (32)	108 (51)	76 (36)
0.9 (225)	100 (47)	51 (24)	102 (48)	59 (28)
1.0 (250)	93 (44)		95 (45)	
Adjusted Sensible Recovery Efficiency @ 32°F (0°C)*	@ 64 CFM (31 L/s) 74%	@ 64 CFM (30 L/s) 71%	@ 66 CFM (31 L/s) 75%	@ 64 CFM (30 L/s) 71%
Sensible Recovery Efficiency @ 32°F (0°C)*	@ 64 CFM (31 L/s) 68%	@ 64 CFM (30 L/s) 69%	@ 66 CFM (31 L/s) 68%	@ 64 CFM (30 L/s) 68%
Adjusted Sensible Recovery Efficiency @ -13°F (-25°C)*	N/A	N/A	@ 70 CFM (33 L/s) 63%	@ 55 CFM (26 L/s) 60%
Sensible Recovery Efficiency @ -13°F (-25°C)*	N/A	N/A	@ 72 CFM (33 L/s) 60%	@ 55 CFM (26 L/s) 60%
Latent Efficiency 95°F (35°C)*	N/A	N/A	N/A	N/A
Total Efficiency 95°F (35°C)*	N/A	N/A	N/A	N/A
*Certified by the Home Ventilating Institute (HVI) according to test procedures developed by HVI members and based on internationally recognized standards. For performance ratings at other conditions not shown, please visit the HVI website.				
Number of speeds available with BC02 basic control	2	2	2	2
Number of speeds available with BC03 basic control	1	N/A	1	N/A
Number of speeds available with BC04 basic control	2	N/A	2	N/A

## Specifications - HRV Units

**Table 3. HRV Specifications (continued)**

Specifications	Single-Core HRV Units			
Model No.	METRO 120F	METRO 120F-ECM	METRO 120D	METRO 120D-ECM
Number of speeds available with DXPL03 Control	5	5	5	5
Ventilator Type	Heat Recovery	Heat Recovery	Heat Recovery	Heat Recovery
Heat Recovery Core	Aluminum	Aluminum	Aluminum	Aluminum
Defrost Type	Fan	Fan	Damper	Damper
Balancing	N/A	N/A	N/A	N/A
Number of Ports	4	4	4	4
Pre-Filters Supply & Exhaust	MERV 6 or MERV 13**			
	** To be ordered separately. Comes in a set of 4 and is installed in the Fresh Side only. When a MERV 13 filter is installed for the first time, airflow will need to be balanced.			
Cup Style Drain Connection:	Yes	Yes	Yes	Yes
Hanging Strap kit Included	No	No	No	No
Mounting Brackets Included	Yes	Yes	Yes	Yes
Electrical Characteristics: 120 Volts, 60 Hertz, 1 phase				
Motor type	PSC	ECM	PSC	ECM
*Fan watts @ HVI Test 32°F (0°C)	@ 64 CFM (30 L/s), 64W	@ 64 CFM (30 L/s), 22W	@ 66 CFM (31 L/s), 66W	@ 64 CFM (30 L/s), 22W
Fan Watt Rating	160	84	130	160
Amp Rating	1.4	1.4	2	1.4
*Certified by the Home Ventilating Institute (HVI) according to test procedures developed by HVI members and based on internationally recognized standards. For performance ratings at other conditions not shown, please visit the HVI website.				

# Optional Fan Curve Speeds - ERV Units

**Table 4. ERV Optional Fan Curves Speeds (Factory Tested)**

Single-Core ERV Units														
Model No.	METRO 120ERV		METRO 120ERV-ECM		MAX XTR		MAX XTR PLUS		METRO 120ERVD		METRO 120ERVD-ECM		METRO XTR	
Speed 5 - High														
IN. wg (Pa)	CFM	L/s	CFM	L/s	CFM	L/s	CFM	L/s	CFM	L/s	CFM	L/s	CFM	L/s
0.1 (25)	138	65			178	84	178	84	133	63			161	86
0.2 (50)	133	63	91	43	168	79	168	79	129	61	90	42	150	71
0.3 (75)	129	61	85	40	157	74	157	74	125	59	85	40	140	66
0.4 (100)	125	59	76	36	146	69	146	69	123	58	73	34	127	60
0.5 (125)	119	56	57	27	133	63	133	63	119	56	59	28	117	55
0.6 (150)	114	54	38	18	121	57	121	57	112	53	38	18	106	50
0.7 (175)	108	51			106	50	106	50	108	51			93	44
0.8 (200)	102	48			93	44	93	44	102	48			81	38
0.9 (225)	93	44			77	36	77	36	95	45			68	32
1.0 (250)	85	40			61	29	61	29	87	41			55	26
Speed 4 - Medium High														
IN. wg (Pa)	CFM	L/s	CFM	L/s	CFM	L/s	CFM	L/s	CFM	L/s	CFM	L/s	CFM	L/s
0.1 (25)	117	55			145	68	145	68	117	56			129	61
0.2 (50)	112	53	85	40	133	63	133	63	112	54	85	40	118	56
0.3 (75)	108	51	80	38	121	57	121	57	110	53	81	38	107	51
0.4 (100)	103	48	63	30	107	51	107	51	105	50	64	30	97	46
0.5 (125)	97	46	42	20	91	43	91	43	98	47	45	21	86	40
0.6 (150)	92	43			77	36	77	36	95	46			75	35
0.7 (175)	87	41			59	28	59	28	88	42			64	30
0.8 (200)	80	38			40	19	40	19	80	38			53	25
0.9 (225)	72	34			22	11	22	11					42	20
1.0 (250)													31	15
Speed 3 - Medium														
IN. wg (Pa)	CFM	L/s	CFM	L/s	CFM	L/s	CFM	L/s	CFM	L/s	CFM	L/s	CFM	L/s
0.1 (25)	100	47			120	57	120	57	100	48			110	52
0.2 (50)	95	45	80	38	107	51	107	51	96	46	80	38	99	47
0.3 (75)	91	43	70	33	93	44	93	44	92	44	72	34	89	42
0.4 (100)	89	42	57	27	74	35	74	35	89	43	55	26	78	37
0.5 (125)	85	40	31	15	59	28	59	28	84	40	31	15	67	32
0.6 (150)	80	38			39	18	39	18	80	38			57	27
0.7 (175)	75	35			20	9	20	9	75	36			46	22
0.8 (200)													36	17
Speed 2 - Medium Low														
IN. wg (Pa)	CFM	L/s	CFM	L/s	CFM	L/s	CFM	L/s	CFM	L/s	CFM	L/s	CFM	L/s
0.1 (25)	86	40			106	50	106	50					87	41
0.2 (50)	82	39	75	35	92	43	92	43			75	35	77	36
0.3 (75)	79	37	61	29	77	36	77	36			61	29	68	32
0.4 (100)	74	35	38	18	56	26	56	26			35	17	58	27
0.5 (125)	69	32			37	17	37	17					48	23
0.6 (150)	64	30			17	8	17	8					39	18
0.7 (175)	57	27											29	14
Speed 1 - Low														
IN. wg (Pa)	CFM	L/s	CFM	L/s	CFM	L/s	CFM	L/s	CFM	L/s	CFM	L/s	CFM	L/s
0.1 (25)	69	32			92	44	92	44	63	30			67	32
0.2 (50)	66	31	69	32	77	37	77	37	60	29	69	33	57	27
0.3 (75)	62	29	51	24	57	27	57	27	57	27	51	24	47	22
0.4 (100)	60	28	20	9	37	18	37	18	53	25	19	9	36	17
0.5 (125)	54	25			17	8	17	8	50	24			26	12
0.6 (150)	44	21							44	21				

# Optional Fan Curve Speeds - HRV Units

**Table 5. HRV Optional Fan Curves Speeds (Factory Tested)**

Single-Core HRV Units

Model No.	METRO 120F		METRO 120F-ECM		METRO 120D		METRO 120D-ECM	
Speed 5 - High								
IN. wg (Pa)	CFM	L/s	CFM	L/s	CFM	L/s	CFM	L/s
0.1 (25)	138	65			140	66		
0.2 (50)	136	64	90	42	136	64	90	42
0.3 (75)	131	62	85	40	131	62	85	40
0.4 (100)	127	60	73	34	127	60	73	34
0.5 (125)	121	57	59	28	123	58	59	28
0.6 (150)	117	55	38	18	119	56	38	18
0.7 (175)	112	53			112	53		
0.8 (200)	106	50			108	51		
0.9 (225)	100	47			102	48		
1.0 (250)	93	44			95	45		
Speed 4 - Medium High								
IN. wg (Pa)	CFM	L/s	CFM	L/s	CFM	L/s	CFM	L/s
0.1 (25)	114	54			114	54		
0.2 (50)	112	53	85	40	111	52	85	40
0.3 (75)	109	51	81	38	109	51	81	38
0.4 (100)	108	51	64	30	108	51	64	30
0.5 (125)	106	50	45	21	106	50	45	21
0.6 (150)	103	49			103	49		
0.7 (175)	96	45			96	45		
0.8 (200)	86	41			86	41		
0.9 (225)	73	34			73	34		
1.0 (250)								
Speed 3 - Medium								
IN. wg (Pa)	CFM	L/s	CFM	L/s	CFM	L/s	CFM	L/s
0.1 (25)	100	47			100	47		
0.2 (50)	96	45	80	38	95	45	80	38
0.3 (75)	94	44	72	34	94	44	72	34
0.4 (100)	93	44	55	26	92	43	55	26
0.5 (125)	88	42	31	15	88	42	31	15
0.6 (150)	82	39			81	38		
0.7 (175)	73	34			73	34		
0.8 (200)								
Speed 2 - Medium Low								
IN. wg (Pa)	CFM	L/s	CFM	L/s	CFM	L/s	CFM	L/s
0.1 (25)	81	47			80	47		
0.2 (50)	79	45	75	35	79	45	75	35
0.3 (75)	77	44	61	29	77	44	61	29
0.4 (100)	74	44	35	17	74	43	35	17
0.5 (125)	70	42			69	42		
0.6 (150)	65	39			64	38		
0.7 (175)	59	34			59	34		
Speed 1 - Low								
IN. wg (Pa)	CFM	L/s	CFM	L/s	CFM	L/s	CFM	L/s
0.1 (25)	64	30			65	31		
0.2 (50)	58	27	69	33	58	27	69	33
0.3 (75)	56	26	51	24	55	26	51	24
0.4 (100)	53	25	19	9	53	25	19	9
0.5 (125)	50	24			50	24		
0.6 (150)	43	20			42	20		

# Dimensional Drawings

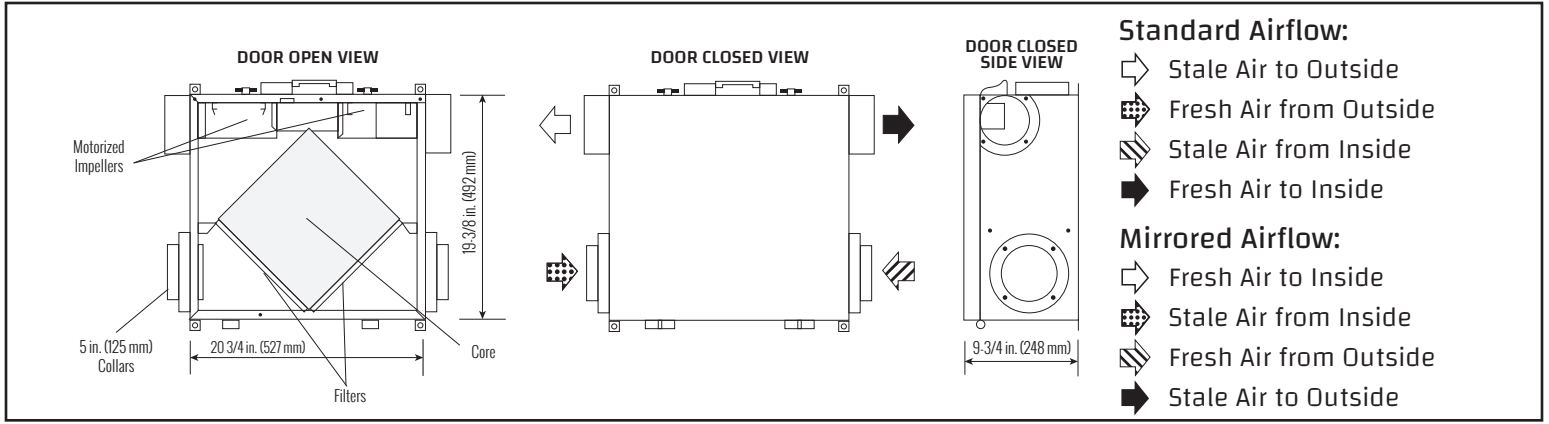

Figure 1. METRO-120ERV & METRO-120ERV-M

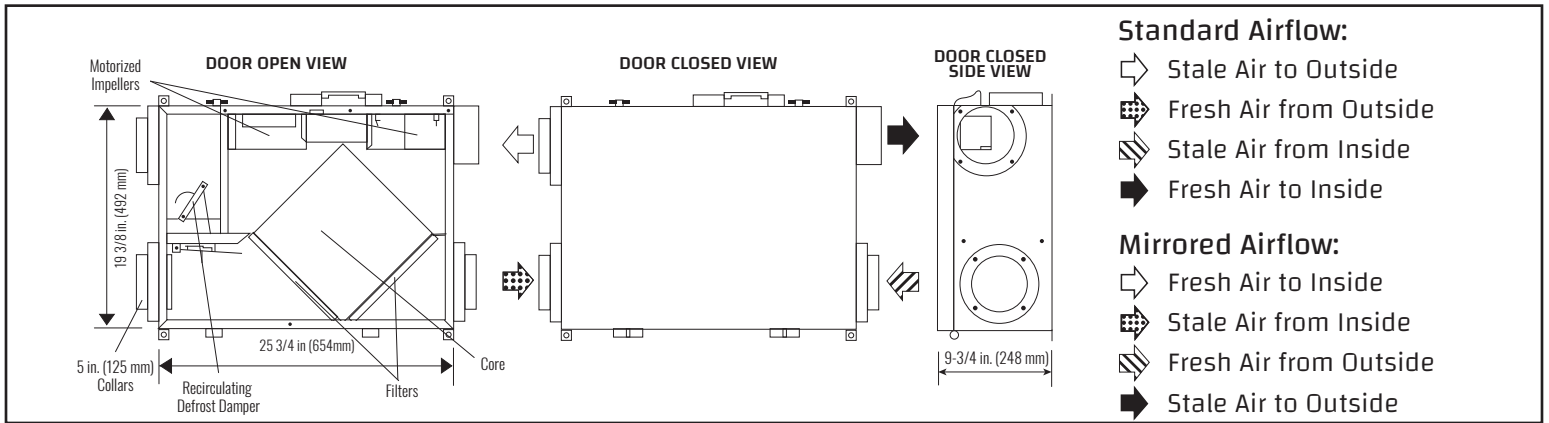

Figure 2. METRO 120ERVD & METRO120ERVD-M

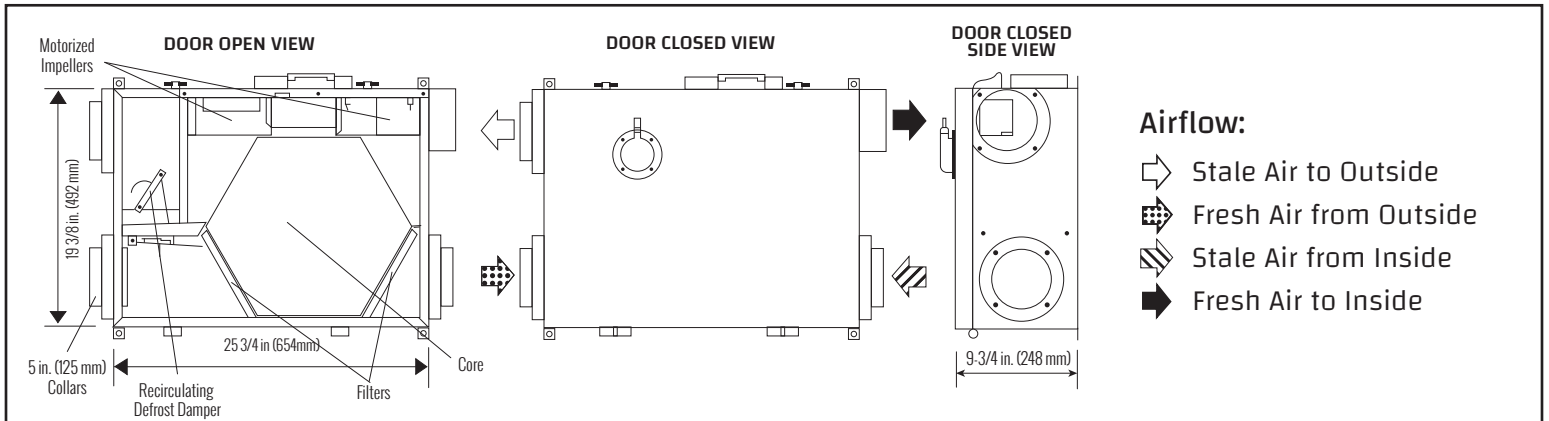

Figure 3. METRO 120D

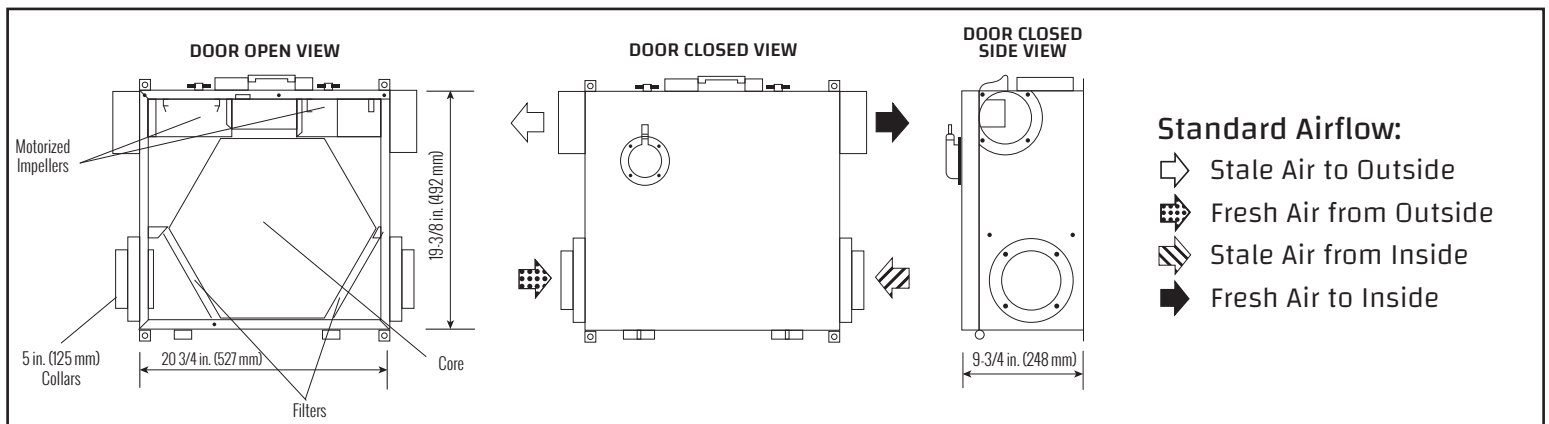

Figure 4. METRO 120F

# Dimensional Drawings (continued)

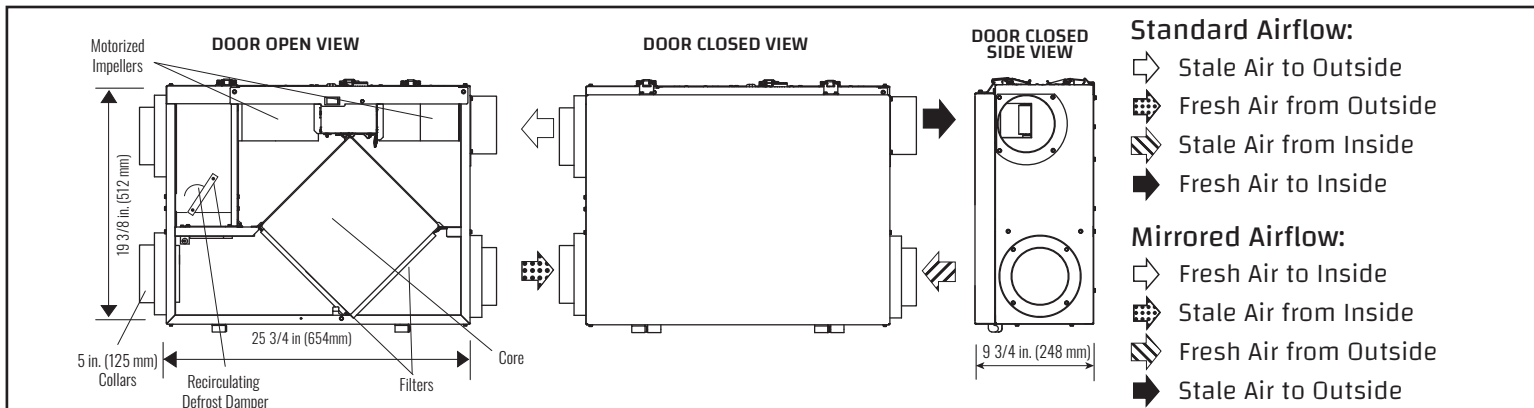

Figure 5. METRO 120 ERVD-ECM & METRO 120 ERVD-ECM-M

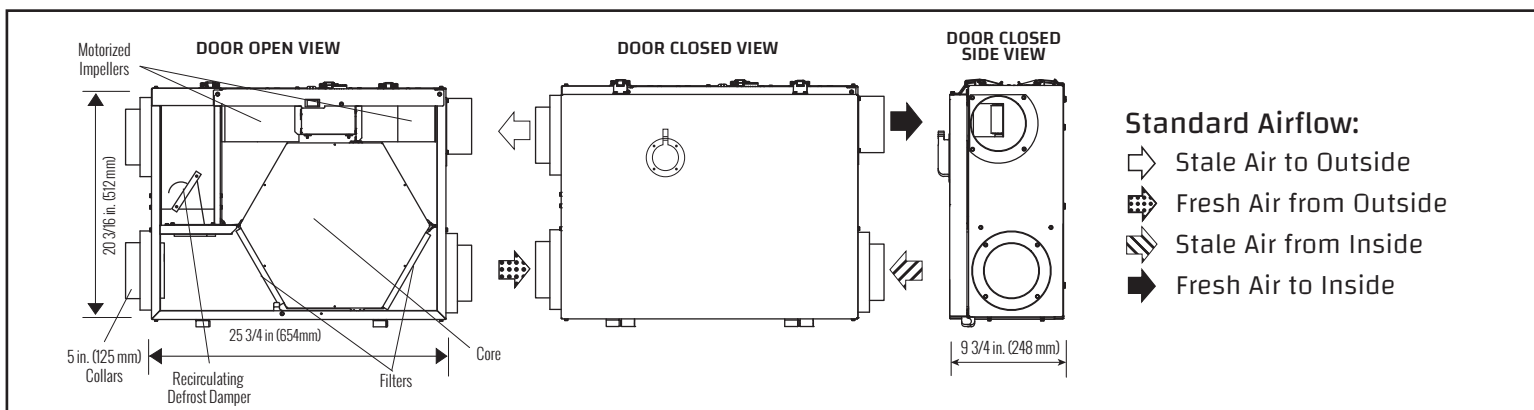

Figure 6. METRO 120D-ECM

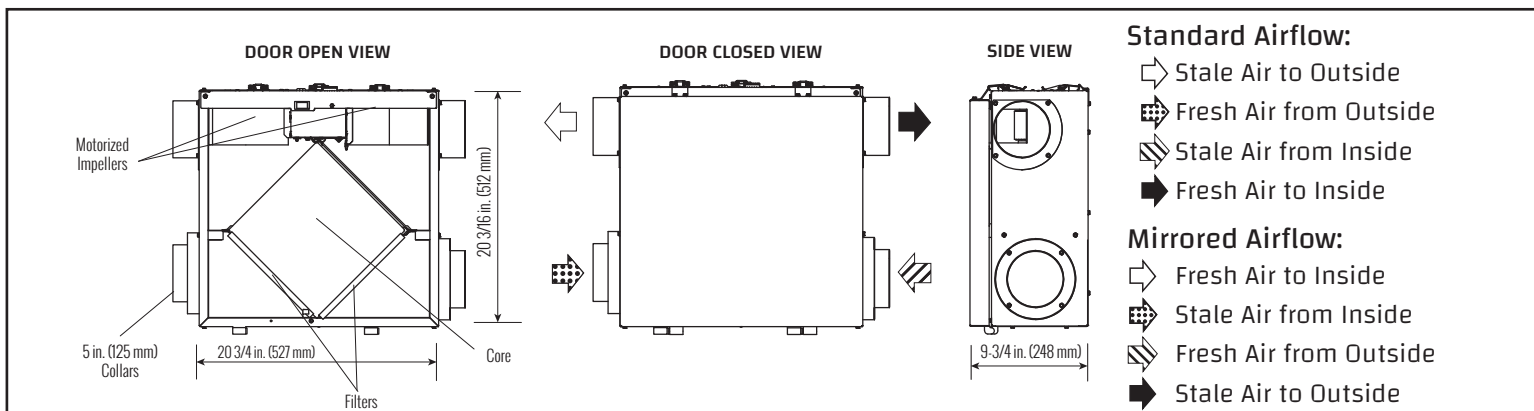

Figure 7. METRO 120 ERV-ECM

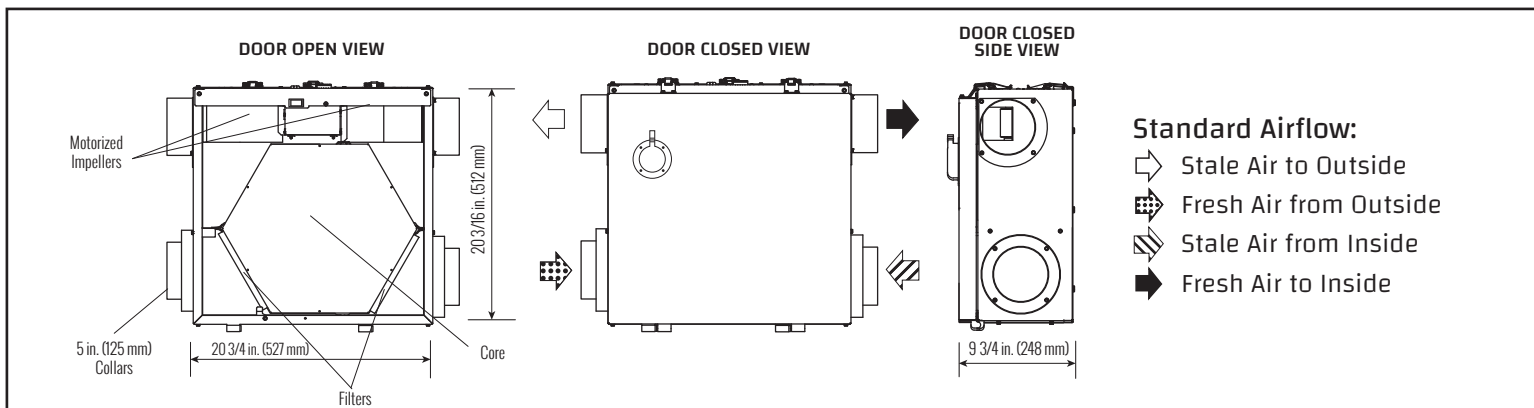

Figure 8. METRO 120F-ECM

# Dimensional Drawings (continued)

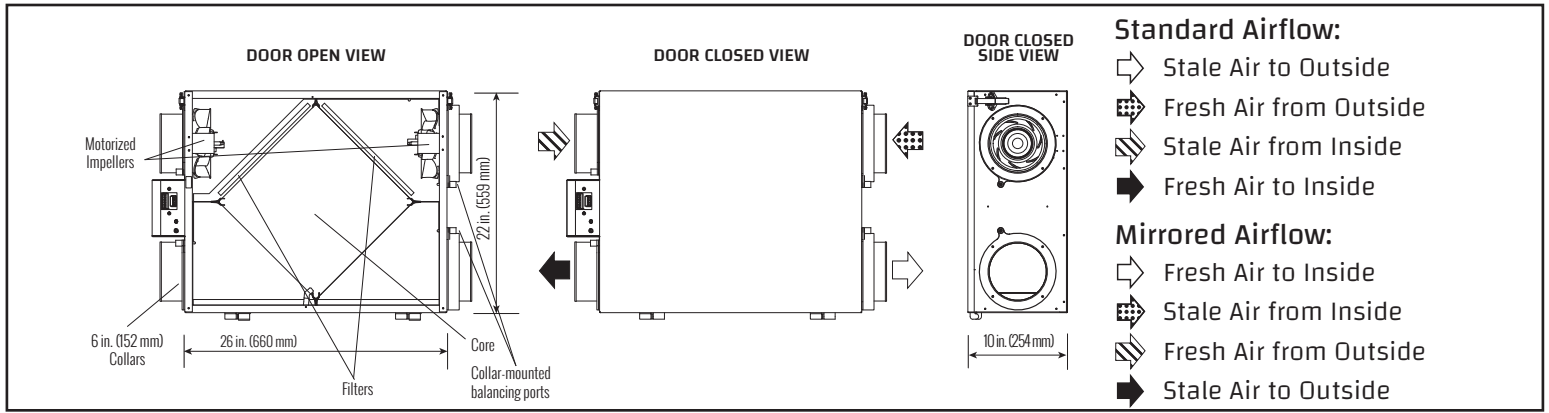

Figure 9. METRO XTR & MAX XTR

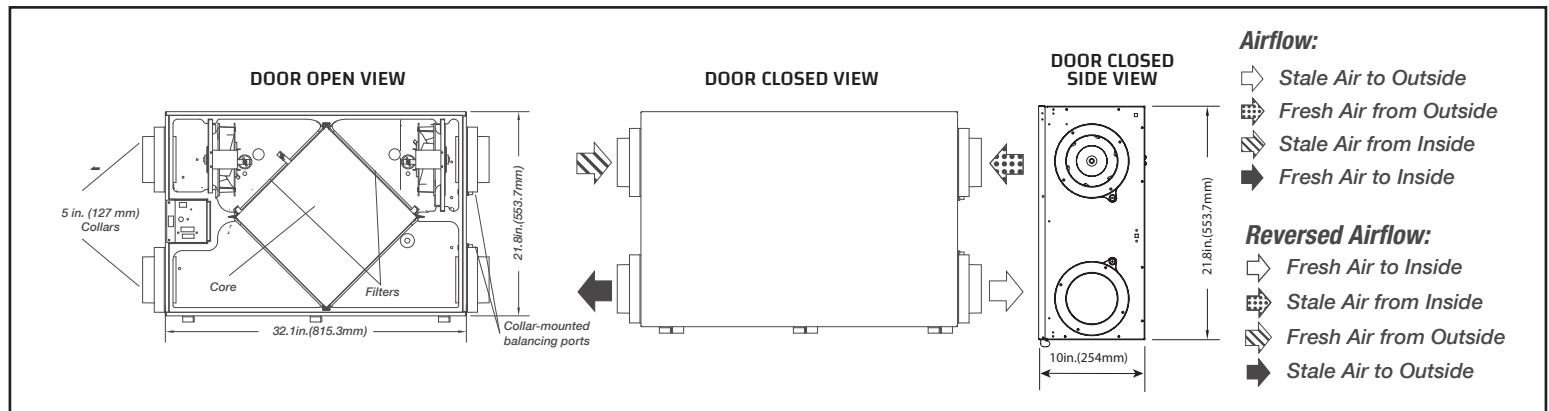

Figure 11. MAX XTR PLUS

## Defrost Cycle

The HRV/ERV has an electronically controlled defrost system. The defrost cycle is activated when the outdoor temperature drops below 27°F (-3°C). Incoming fresh air temperature is constantly measured to determine if defrost is required. The three defrost settings are:

- At 27°F (-3°C) HRV/ERV runs in defrost for 3 minutes and runs in ventilation for 25 minutes
- At -4°F (-20°C) HRV/ERV runs in defrost for 4.5 minutes and runs in ventilation for 17 minutes
- At -31°F (-35°C) HRV/ERV runs in defrost for 7 minutes and runs in ventilation for 15 minutes

No remote device can override this defrost mode until the cycle is complete. After the cycle is completed, the HRV/ERV defaults to previous settings. If the cycle is completed and the thermistor continues to measure defrost temperature the defrost cycle is repeated.

## Recirculating Damper Defrost

Applicable Units:

METRO 120ERVD, METRO 120ERVD-ECM, METRO 120D, & METRO 120D-ECM

During defrost a motor driven damper door mechanism closes off the supply air from outside allowing stale air to recirculate through the unit's core. During the defrost portion of the cycle no ventilation is occurring. After the defrost portion of the cycle, the damper operates in the opposite direction to reopen the fresh air port. The defrost cycle repeats until the temperature rises above 27°F (-3°C).

## Fan Defrost

Applicable Units: METRO 120ERV, METRO 120ERV-ECM, METRO 120F, METRO 120F-ECM, METRO XTR, MAX XTR & MAX XTR PLUS.

During defrost the supply fan shuts off while the exhaust fan continues to operate. This allows the heat from the stale air to defrost the unit's core. During the defrost portion of the cycle, the unit operates with only exhaust ventilation. After the defrost portion of the cycle, the supply fan powers on and operates with balanced ventilation. The defrost cycle repeats until the temperature rises above 27°F (-3°C).

## Required Ventilation

ASHRAE

- ASHRAE 62.2-2019 is a national standard that provides methods for achieving acceptable indoor air quality in typical residences. It was developed and is maintained by the American Society of Heating and Air-Conditioning Engineers (ASHRAE).
- This standard recommends Dwelling-Unit Ventilation, which is a mechanical exhaust system, supply system, or combination thereof.

Formula Method

The Building Ventilation rate is determined based on the floor area and the number of bedrooms, as defined in Section 4.1.1 equation 4-1a.

Formula

(Square feet x 0.03) + (bedrooms + 1) x 7.5 = Required Ventilation

(2000 x 0.03) + (4+1) x 7.5 = 97.5

Table Method

Example: A 2000 square foot building with 4 bedrooms from Section 4.1.1 Table 4-1a, a quick reference table predicts 98 cfm. The following table complies with ASHRAE Standard 62.2-2019, Section 4.1.1 Table 4-1a, Continuous Whole-Building Ventilation rate in cfm.

**Table 6. Whole Building Ventilation Air Requirements**

Floor Area (Square Feet)	Number of Bedrooms				
	1	2	3	4	5
	CFM	CFM	CFM	CFM	CFM
<500	30	38	45	53	60
501 - 1000	45	53	60	68	75
1001 - 1500	60	68	75	83	90
1501 - 2000	75	83	90	98	105
2001 - 2500	90	98	105	113	120
2501 - 3000	105	113	120	128	135
3001 - 3500	120	128	135	143	150
3501 - 4000	135	143	150	158	165
4001 - 4500	150	158	165	173	180
4501 - 5000	165	173	180	188	195

For more information about ASHRAE, go to: <https://www.ashrae.org>.

## How the Dehumidistat Works

When using either the BC02, BC03 or the DXPL03 a built-in dehumidistat is present. The following information is provided on how it works.

High indoor humidity levels, during the heating season, have become a problem in many well insulated, tight homes. Excessive condensation on the windows is a visual sign of high indoor humidity levels. High indoor humidity levels can result in mold, mildew and the eventual degradation of the building structure itself. Your HRV/ERV reduces indoor humidity levels when the outdoor air is drier than the indoor air.

These conditions usually occur during the heating season when outdoor temperatures are less than 59°F (15°C).

During the heating season, the operation of the HRV/ERV may reduce indoor humidity levels sufficiently to eliminate the need for further dehumidification. Use the adjustable dehumidistat feature located on the control if your home requires further dehumidification during the heating season.

The dehumidification function aggressively addresses high indoor humidity levels by initiating high speed ventilation when the indoor humidity levels rise above the set point on the control. Once the humidity in the house is reduced, the HRV/ERV will revert back to its previous setting.

It is recommended to operate the HRV/ERV for the first few days without use of the dehumidistat function to observe if a further dehumidification effect will be required.

The dehumidistat operates in percentage of RH (relative humidity) with 60 being high and 20 being low. If after a few days, further dehumidification is required (the building is still too humid), set the humidity level to a lower amount.

The average person is comfortable between 30% and 50% RH. The dehumidistat should be set to OFF for all seasons except the heating season since a dehumidifying effect only occurs when the outdoor air is dryer than the indoor air.

### **Dehumidification Sensing**

Every 6 hours the HRV/ERV will run and sample the outdoor air temperature for 3 minutes (this includes when the unit is in Standby mode) to read the outdoor temperature. The unit then resumes operations at the selected mode and speed. Dehumidistat Disable or Dehumidistat Re-enable may be initiated.

**Dehumidistat Disable** automatically disables the Dehumidistat function on the main wall control when outdoor temperatures exceed 15°C (59°F) for a full 24-hour period. All other HRV/ERV features, and functions operate normally while the Dehumidistat function is disabled.

**Dehumidistat Re-enable** automatically re-enables the Dehumidistat function if either the outdoor temperature drops below 15°C (59°F) for a full 24-hour period or if the HRV/ERV is reset (unplugged for 30 seconds).

## BC02 Basic Control

The control offers the following features to control your home's ventilation.

- Two-speed fan setting (LOW / HIGH)
- Standby setting (fan OFF)
- Electronic dehumidistat
- Compatible with wireless timers
- Connect to 3-wire 20 gauge (minimum) low voltage wire.
- Designed to be mounted in a standard 2 x 4" (51 x 102 mm) electrical box or surface mounted to a wall.

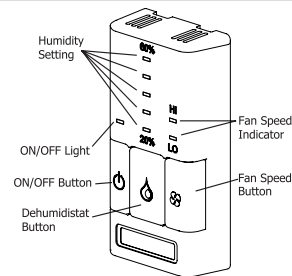





Figure 10. BC02 Basic Control

**Table 7. BC02 Basic Control**

Settings	Icon	Description
Turning on the Control		Press and release the ON/OFF button. The light above will illuminate.
Setting the Ventilation Speed		Press and release the Fan Speed button to select LOW or HIGH fan speed. The corresponding "Indicator Light" will illuminate. If both LO and Hi Indicator Lights are off, the fan is OFF but will turn ON if required by the Dehumidistat or remote Timer (if installed).
Humidity Control		Your unit will reduce indoor humidity when outdoor humidity levels are lower than indoor humidity levels. This feature is only effective when the outdoor temperature is below 59°F (15°C).
Setting the Dehumidistat		Press and release the Dehumidistat Button until the Dehumidistat Light is at the desired setting. After a few seconds the Dehumidistat light will either flash or be on continuous. A flashing light indicates the humidity level is higher than the setting and the unit is operating on high speed ventilation. A continuous light indicates the humidity level is lower than the setting. The Dehumidistat will override the current speed setting to HIGH speed. The Dehumidistat function can be turned OFF by pressing the button until no Dehumidistat Light is on. Refer to the "How the Dehumidistat Works" on page 13 of this instruction for a detailed description of Dehumidistat functionality.

### **IMPORTANT**

Only one control can be installed on the system.

Timers will not function when mode of operation is set to "OFF", unless specifically installed for that function. Refer to "Installing Standby Jumper" on page 32.

## BC03 Basic Control

**Note: The MAX XTR, MAX XTR PLUS, METRO 120D-ECM, METRO 120F-ECM, METRO 120 ERVD-ECM, & METRO 120 ERV-ECM CANNOT be controlled by a BC03 basic control.**

The control offers the following features to control your home's ventilation.

- Low-speed fan setting
- Electronic dehumidistat
- 20min on / 40min off mode (fan defrost models)
- 20min on / 40min recirculation mode (damper defrost models)
- Continuous recirculation mode (damper defrost models only)
- Compatible with Wireless Timers
- Connect to 3 wire 20 gauge low voltage wire
- Designed to be mounted in a standard 2 x 4" (51 x 102 mm) electrical box or surface mounted to a wall.

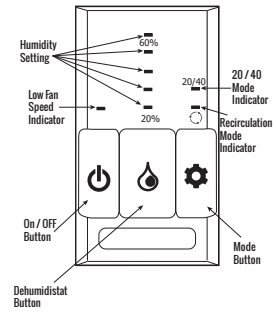

Figure 11. BC03 Basic Control

Table 8. BC03 Basic Control		
Settings	Icon	Description
Turning on the Control		Press and release the ON/OFF button. The light above will illuminate, and the unit will run at low speed.
Humidity Control		Your unit will reduce indoor humidity when outdoor humidity levels are lower than indoor humidity levels. This feature is only effective when the outdoor temperature is below 59°F (15°C).
Setting the Dehumidistat		Press and release the Dehumidistat button until the Dehumidistat Light is at the desired setting. After a few seconds the Dehumidistat Light will either flash or be on continuous. A flashing light indicates the humidity level is higher than the setting and the unit is operating on high speed ventilation. A continuous light indicates the humidity level is lower than the setting. The Dehumidistat will override the current speed setting to HIGH speed. The Dehumidistat function can be turned OFF by pressing the button until no Dehumidistat Light is on. Refer to the "How the Dehumidistat Works" on page 13 of this instruction for a detailed description of Dehumidistat functionality.
20/40 Mode		Press the Mode Button  until the 20/40 mode indicator light is illuminated. The 20/40 mode is a repeating cycle. The fan will run at LOW speed for 20 minutes, then turn OFF for 40 minutes. Some units are equipped to recirculate the air in your home during the 40-minute cycle with no ventilation. The control will automatically detect this feature and recirculate the air during the 40-minute cycle at LOW fan speed.

## BC04 Basic Control

**Note: The MAX XTR, MAX XTR PLUS, METRO 120D-ECM, METRO 120F-ECM, METRO 120 ERVD-ECM, & METRO**

**120 ERV-ECM CANNOT be controlled by a BC04 basic control.**

The control offers the following features to control your home's ventilation.

- Two-speed fan setting (LOW / HIGH)
- Standby setting (fan OFF)
- 20min on / 40min off mode (fan defrost models)
- 20min on / 40min recirculation mode (damper defrost models)
- Compatible with Wireless Timers
- Connect to 3 wire 20 gauge low voltage wire
- Designed to be mounted in a standard 2 x 4" (51 x 102 mm) electrical box or surface mounted to a wall.

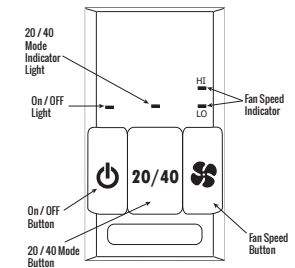

Figure 12. BC04 Basic Control

Table 9. BC04 Basic Control		
Settings	Icon	Description
Turning on the Control		Press and release the ON/OFF button. The light above will illuminate.
Setting the Ventilation Speed		Press and release the Fan button to select LOW or HIGH fan speed. The corresponding "Indicator Light" will illuminate. If both LO and Hi Indicator Lights are off, the fan is OFF but will turn ON if required by the Dehumidistat or remote Timer (if installed).
20/40 Mode	<b>20 / 40</b>	Press and release the 20/40 button. The light above will illuminate. The unit will run 20 min on / 40 min off mode in fan defrost models and 20 min on / 40 min recirculation mode on recirculation damper defrost models.

# DXPL03 Deluxe Control

**Note: ALL UNITS can be controlled by DXPL03 deluxe control.**

The control offers the most advanced features to control your home's ventilation.

- Five-speed fan setting
- Standby setting (fan speed 0)
- Electronic dehumidistat
- 20/40/60 HIGH Speed override Button
- Compatible with Wireless Timer
- Easy to read back-lit LCD screen
- Connect to 3-wire 20 gauge (minimum) low voltage wire
- Auto Balancing (applicable units)\*

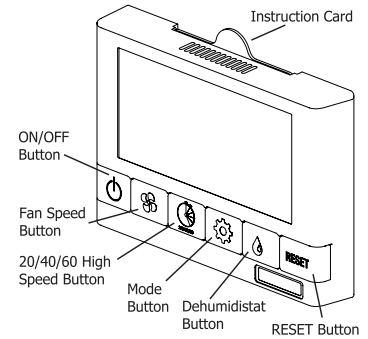

Figure 13. DXPL03 Deluxe Control

**Table 10. DXPL03 Operational Modes**

Function	Icon
Continuous Ventilation	
20 Minutes On, 40 Minutes Recirculation	
20 Minutes On, 40 Minutes OFF	
10 Minutes On, 50 Minutes OFF	
Continuous Recirculation	

**Table 11. DXPL03 Deluxe Control Settings**

Mode	Icon	Description
Turning on the Control		Press and release the ON/OFF button. The light above will illuminate.
Setting the Ventilation Speed		Press and release the Fan button to select one of the five fan speeds. The fan speed will be displayed on the screen beside to fan symbol. Standby mode (Fan OFF) is indicated as speed 0. The fan will turn ON if required by a remote timer (if installed).
20/40/60 High Speed Button		Press and release the 20/40/60 High Speed button to temporarily initiate HIGH Fan speed for 20, 40 or 60 minutes. Press once for 20 minutes, twice for 40 minutes, three times for 60 minutes and four times to disable. The timer symbol will appear on the screen and the corresponding section of the clock will flash to indicate the time interval selected. When the timer runs out, the unit will return to its previous operating speed.
Setting the Mode of Operation		There are five modes of operation available with the DXPL03 (see Table 10). Pressing the Mode button will display the different modes of operation on the screen. Fan defrost models do not have recirculation modes available.
Setting the Dehumidistat		The DXPL03 displays the current indoor humidity in LARGE numbers and the Dehumidistat setting in SMALL numbers on the screen. If the indoor humidity is above the set point, the control will initiate HIGH Fan speed operation in Ventilation mode until the indoor humidity has been reduced below the set point. Press and release the Dehumidistat button to adjust the Dehumidistat setting. The Dehumidistat can be set between 25% RH and 60% RH. To disable the Dehumidistat function on the control, cycle through the setting until OFF is displayed. Refer to "How the Dehumidistat Works" on page 12 in this instruction for a detailed description of the Dehumidistat function.
Reset Button	RESET	The RESET button will clear the current Fan, Timer, Mode and Dehumidistat settings and set the unit into LOW fan speed, Ventilation mode and a Dehumidistat setting of 40%.
Service Indicator		A service indicator appears when the unit requires routine maintenance. Press and hold the ON/OFF button for 5 seconds to reset the service indicator once maintenance has been performed.
Defrost		The defrost symbol will be displayed on the screen of the DXPL-03 when the defrost cycle is engaged and the unit is actively defrosting.
Wireless Symbol		The wireless connection symbol will be displayed on the screen of the DXPL-03 when a wireless signal is received from the DET-02, RX-02, and when the DXPL-03 is put into wireless pairing mode.

\*Refer to "Auto Balancing" on page 40.

## DET01 Wired Timer

Timers are available as wired or wireless. The timer will override the operational mode of the control (regardless of the setting) and initiate HIGH fan speed Ventilation for 20, 40 or 60 minutes. The HRV/ERV will return to the selected operational mode and fan speed setting upon completion of the timer cycle.

### Using Timers

Press the button to initiate high speed ventilation for 20, 40 or 60 minutes. The corresponding status light will illuminate to indicate either 20, 40 or 60 minutes of high speed fan operation. Press the button until the status lights are no longer illuminated to cancel high speed timer operation.

### Optional Lockout Mode

The Wired Timer has a lockout mode feature that can be set to disable the timer. Set the lockout mode by holding the button for five seconds. Disable lock-out mode by holding the button for 5 seconds. Connect to 3-wire, 20-gauge (min.) low-voltage wire and install in a standard 2 x 4" (51 x 102 mm) electrical box.

\*Refer to "Installation and Operation of DET01 Timer" on page 34.

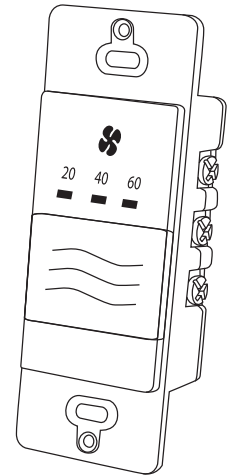

Figure 14. DET01 Wired Timer

## DET02 Wireless Timer

The DET02 Wireless Timer pairs wirelessly to the control. The DET02 Wireless Timers have an estimated range of 40 feet (12 meters) with no obstructions. To increase the range of the timer, a RX02 Repeater may be used. Multiple timers can be paired to a single control. They are designed to be mounted in a standard 2 x 4" (51 x 102 mm) electrical box or surface mounted to a wall.

### Replacing The Battery

The red LED battery indicator will illuminate when the battery on the timer needs to be replaced. Replace the battery by:

- Pulling the face plate off the wall.
- Replacing the battery located on the back of the Timer Face Plate.
- Re-attaching the face plate to the back plate. Be careful not to damage the tabs on the back plate when reattaching the face plate.

\* Refer to "Installation and Operation of DET02 Wireless Timer" on page 29 for pairing instructions.

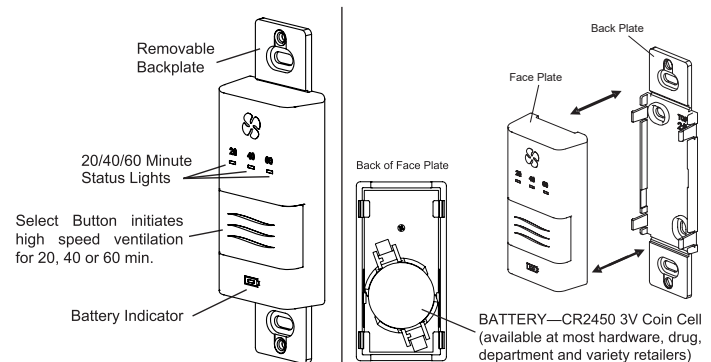

Figure 15. DET02 Wireless Timer

## RX02 Repeater

This device is used to extend the range of the DET02 Wireless Timer. The RX02 Repeater plugs directly into a 120 V power outlet.

The RX02 Repeater should be installed at the halfway point between the DET02 Minute Wireless Timer and the control if the timer is out of range.

When the RX02 Repeater is positioned correctly, a solid green LED will illuminate indicating the RX02 Repeater has a strong connection to the main wall control and may be moved farther away if necessary.

\* Refer to "Installation and Operation of RX02 Repeater" on page 30.

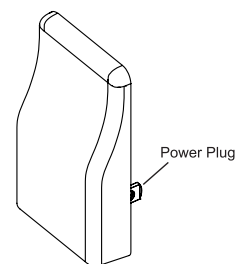

Figure 16. Wireless Repeater

## Overview of Installation Methods

There are three methods of installation for the HRV/ERV:

- Simplified installation - See “Installation Methods - Simplified (Return/Return)” on page 19.
- Partially dedicated installation - See “Installation Methods - Partially Dedicated” on page 20.
- Fully dedicated installation - See “Installation Methods - Fully Dedicated” on page 21.

## Connecting the Ductwork

The installer must ensure all ductwork is sized and installed as designed to ensure the system will perform as intended.

The amount of air that the HRV/ERV unit will deliver is directly related to the total external static pressure of the system. Static pressure is a measure of resistance imposed on the blower by the length of ductwork plus the number of fittings used in the ductwork.

A well designed and installed ducting system will allow the HRV/ERV to operate at its maximum efficiency.

All ducts should be kept as short as possible and have as few bends or elbows as possible to maximize airflow. 45° elbows are preferred to 90° elbows. Use Y-fittings instead of T-fittings whenever possible.

All duct joints must be fastened with screws, rivets or duct sealant and wrapped with mastic or quality duct tape to prevent leakage. Mastic is preferred but if duct tape is used it should be the aluminum foil type.

Use galvanized (rigid) ducting whenever possible although flexible duct can be used in moderation, if necessary.

A short length (approximately 12 inches [300 mm]) of non-metallic flexible duct should be connected between the HRV/ERV and the supply/exhaust duct system to avoid possible noise transfer through the duct system.

All ducts running through attics and unheated spaces must be sealed and insulated to code.



### IMPORTANT

Applications such as greenhouses, atriums, swimming pools, saunas, etc. have unique ventilation requirements which should be addressed with an isolated ventilation system.

## Installation Methods - Simplified (Return/Return)

The simplified method draws stale air from the cold air return duct of the air handler/furnace and introduces an equal amount of fresh air farther downstream into the cold air return as illustrated in the following figures.

### Key Points

The HRV/ERV unit should be balanced.

- It is recommended that either the furnace blower run continuously or HRV/ERV unit operation be interlocked with the furnace blower.
  - \* Refer to “Interlocking HRV/ERV to Air Handler / Furnace Blower” on page 31.
- The duct configuration may change depending on the HRV/ERV model. See specifications for your unit.
- Check local codes and authority having jurisdiction for acceptance.

### Installation Notes

- See unit specifications for exact port locations (METRO XTR / MAX XTR / MAX XTR PLUS shown in image below).
- Unit is normally balanced on HIGH speed with the furnace blower ON.
- Ensure as much distance as possible between the supply and exhaust connections to the cold air return of the furnace.
- The exhaust air connection should be upstream of the supply air connection to prevent exhausting any fresh air.
- Weatherhood arrangement is for drawing purposes only. The weatherhoods are to be installed in accordance with local building codes or manufacturer recommendations.
- The airflow can be confirmed on site using the balancing procedures found in this manual.

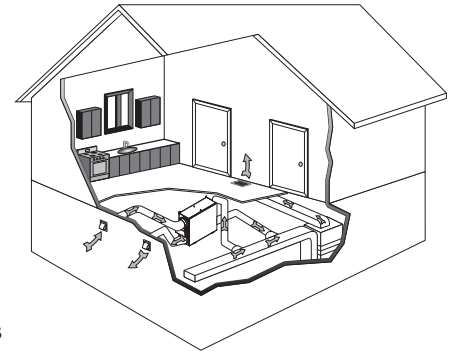

Figure 17. Simplified Installation (Return/Return)

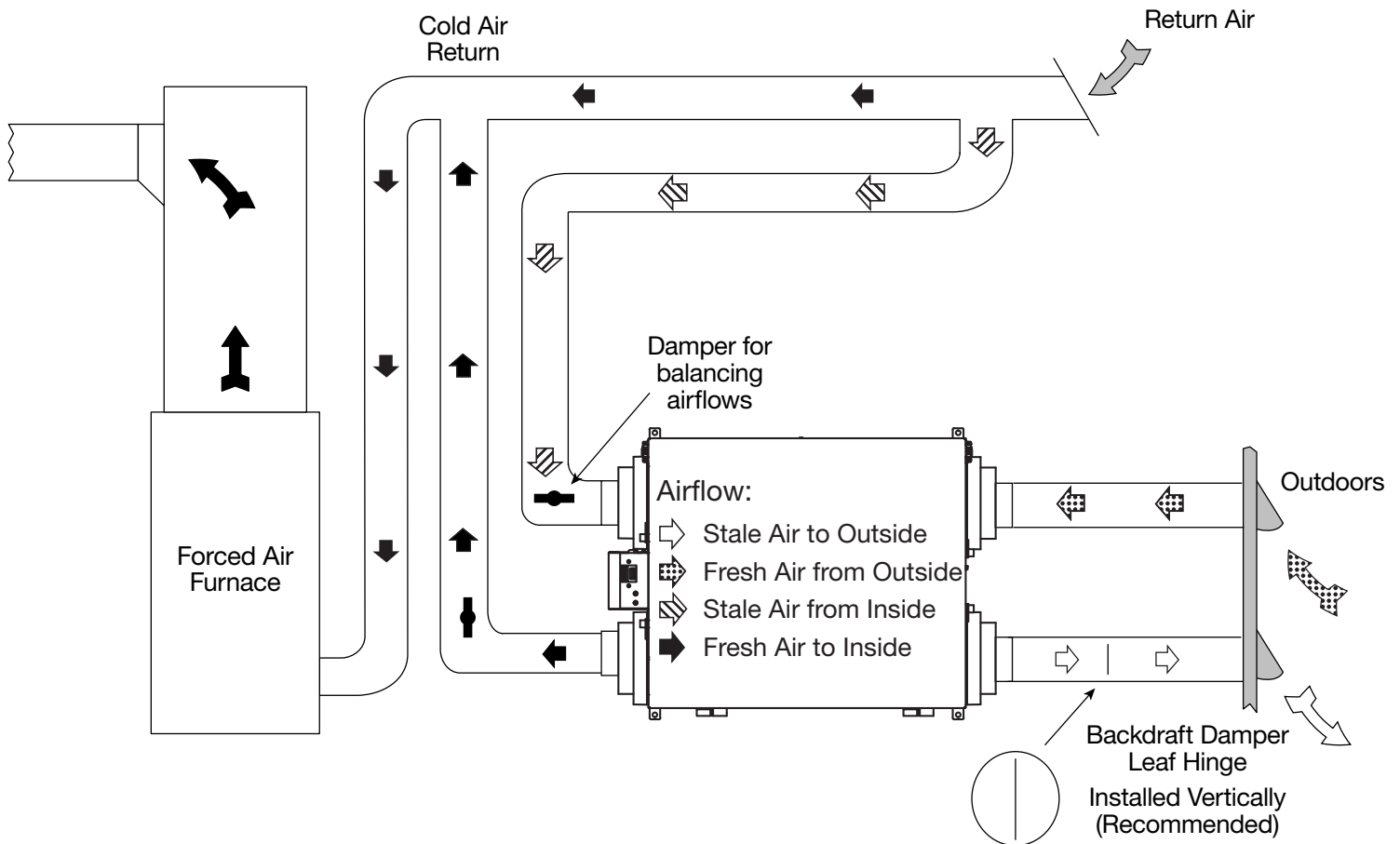

Figure 18. Simplified Installation (Return/Return)

## Installation Methods - Partially Dedicated

The partially dedicated installation draws stale air from specific points in the house and introduces an equal amount of fresh air into the cold air return as illustrated in the following building figures.

### Key Points

The HRV/ERV unit should be balanced.

- It is recommended that the furnace blower run continuously or HRV/ERV operation be interlocked with the furnace blower to evenly distribute the fresh air throughout the house. Refer to building code.  
\* Refer to “Interlocking HRV/ERV to Air Handler / Furnace Blower” on page 31.
- The duct configuration may change depending on the HRV/ERV model. See specifications for your unit.
- Check local codes and authority having jurisdiction for acceptance.

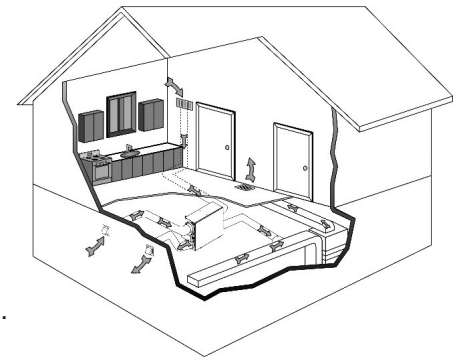

Figure 19. Partially Dedicated System

### Installation Notes

- See unit specifications for exact port locations (METRO XTR / MAX XTR / MAX XTR PLUS shown in image below).
- Unit is normally balanced on HIGH speed with the furnace blower ON.
- Weatherhoods are to be installed in accordance with local building codes or manufacturer recommendations.
- The airflow must be confirmed on site using the balancing procedures found in this manual.

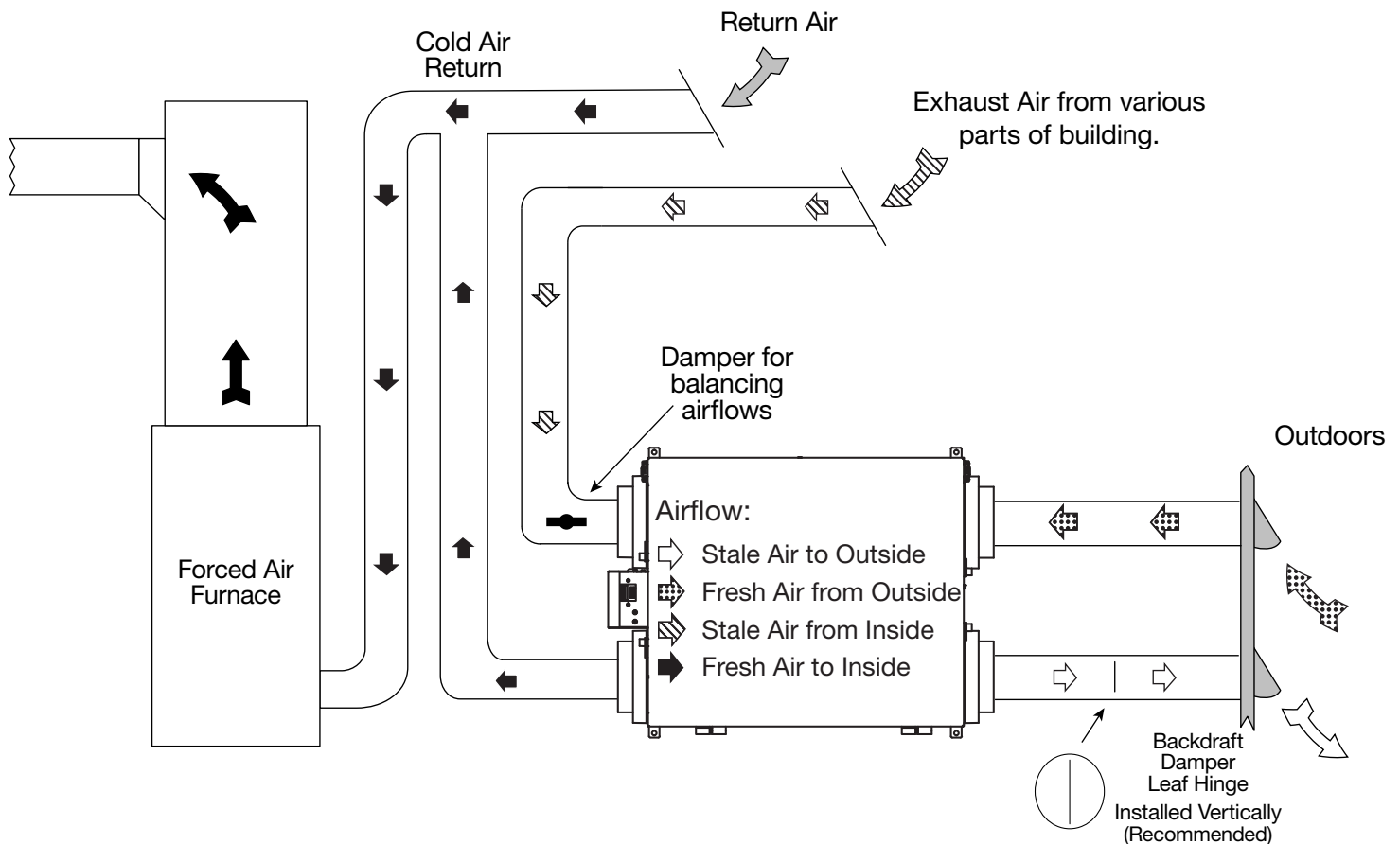

Figure 20. Direct Connection of Supply Air Stream to the Furnace Cold Air Return (Stale air drawn from key areas of home)

## Installation Methods - Fully Dedicated

The fully dedicated installation draws stale air from specific points in the building and delivers fresh air to specific locations of the building. This system is not connected to an air handler/ furnace (see the following figures).

### KEY POINTS

The HRV/ERV unit should be balanced.

- The duct configuration may change depending on the HRV/ERV model. See specifications for your unit.
- Check local codes and authority having jurisdiction for acceptance.

### Installation Notes

- See unit specifications for exact port locations (METRO XTR / MAX XTR / MAX XTR PLUS shown in image below).
- Unit is normally balanced on HIGH speed.
- Weatherhoods are to be installed in accordance with local building codes or manufacturer recommendations.
- The airflow must be confirmed on site using the balancing in this instruction.

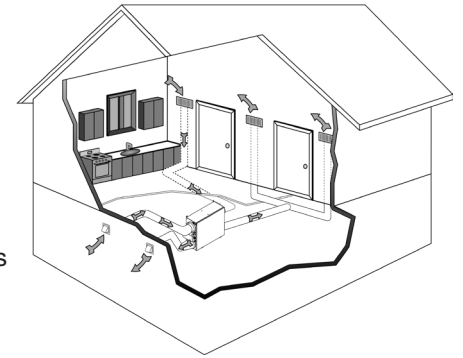

Figure 21. Fully Dedicated System

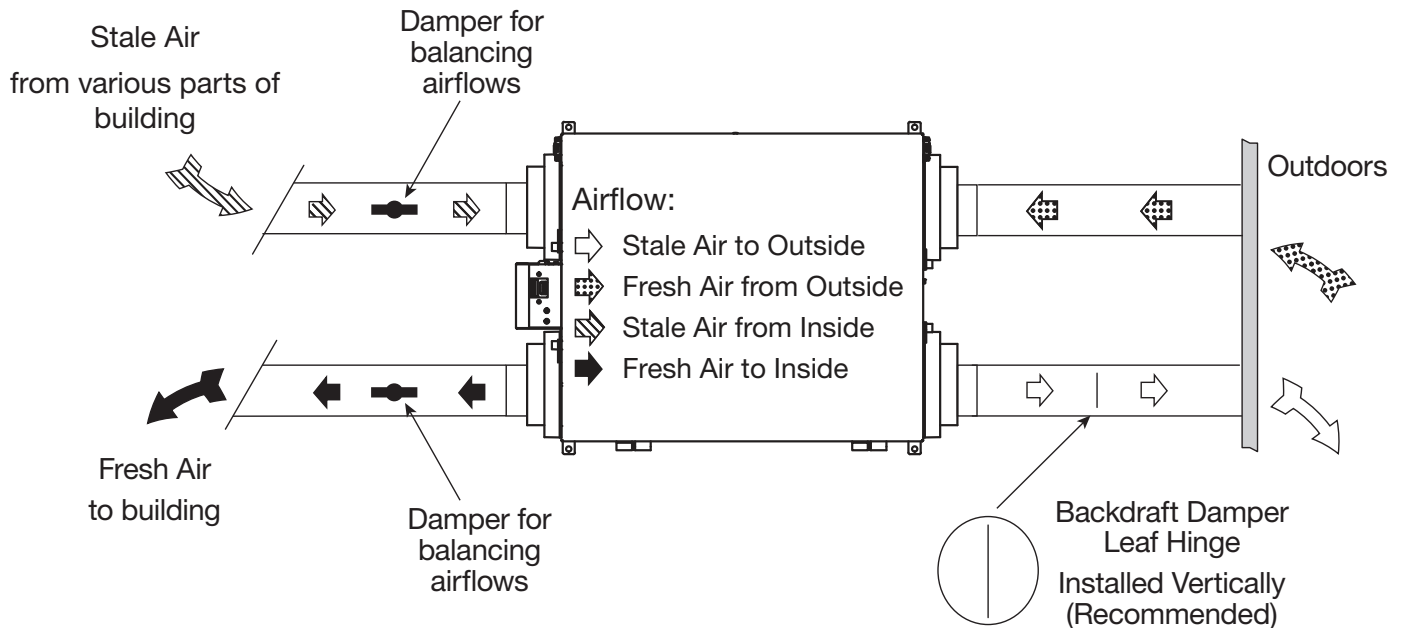

Figure 22. Fully Dedicated System (Not connected to forced air system)

## Unit Installation Location

Install the unit in a heated space that provides clearance for service access. A typical location is in either a mechanical room or an area close to the outside wall within proximity to where the weather hoods are mounted. If a basement area is inconvenient or non-existent, install the unit in a utility room or laundry room.

Slim design units are ideal for installation in multi unit residential buildings (MURBs). The slim design allows the unit to fit in a standard 10 inch drop down ceiling with an access panel for maintenance. Other common installation locations are in a closet, above a hot water tank, or above a stacked washing machine and dryer. MURB installations often use the slim design units as the sole stale ventilation means for the bathroom.

Attic installations are not recommended due to:

- The complexity of work to install
- Difficulty of access for servicing and cleaning
- Freezing conditions in the attic

If attic installation is necessary, the unit must be situated in a conditioned space.

## Unit Installation Restrictions

The following appliances should not be connected to the HRV/ERV unit:

- Clothes dryer
- Stove top fan
- Central vacuum system

NOTE: Failure to follow this instruction will void the HRV/ERV unit warranty.

### CAUTION

If possible, avoid installing units above areas or equipment that are sensitive to water damage. Otherwise, the use of an auxiliary drain pan under the installation is recommended.

Risk of carbon monoxide poisoning and/or explosion.

Can cause injury or death.

Combustion and flue gases from heating appliances must never be allowed to enter living spaces.

HRV/ERV unit must be properly balanced (see page 35 - 37) to prevent negative pressure in structure. Negative pressure can cause back-drafting of combustion gases in other household appliances such as gas furnaces, oil furnaces, hot water heaters, wood stoves, fireplaces, etc.

## Mounting the Unit

**Note:** Only the METRO XTR, MAX XTR & MAX XTR PLUS have the option of wall mounting the unit.

1. Using the hardware provided, install the mounting brackets on the unit. It is important to isolate the mounting brackets from the mounting surface to minimize vibration.
2. Install the unit to the mounting surface, using the mounting brackets provided.

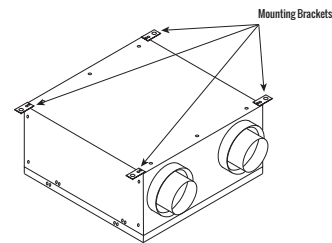
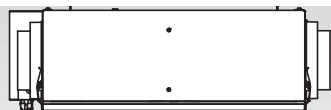
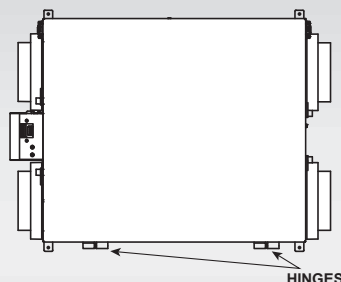

Figure 23. Mounting Brackets



Ceiling Mounted



**Wall Mounted**  
Must have hinges downward  
towards the floor  
(METRO XTR, MAX XTR & MAX XTR PLUS only)

Figure 24. Ceiling Mounting vs. Wall Mounting



### IMPORTANT

Do not drill additional holes in the HRV/ERV  
Due to natural condensate accumulation, the unit must have the door hinges directed towards the floor in wall mount configuration (METRO XTR, MAX XTR & MAX XTR PLUS only).

## Installing the Drain Connection (HRV's only)

Applicable Units: METRO 120F, METRO 120D, METRO 120F-ECM, & METRO 120D-ECM.

The HRV's have a 4-position drain spout to allow for easy and quick installation of the condensate drain hose (see below). The HRV may produce some condensation during a defrost cycle. This water should flow into a nearby drain or be taken away by a condensate pump.

### Figure Callouts:

1. Drain Spout
2. Drain Pan Inside Door
3. 1/2 in. Drain Hose

### Installation Steps:

1. Position drain spout and fasten to HRV cabinet with 4 sheet metal screws provided. The preferred direction is with spout directed towards the hinges of the door for ease of future maintenance of the unit.
2. Seal drain spout to bottom of HRV cabinet with silicone.
3. Cut one length of 1/2 in. drain hose (not included) and connect to the drain spout.

**PLEASE NOTE:** Installer should consider location of the drain spout in respect to the service and maintenance.

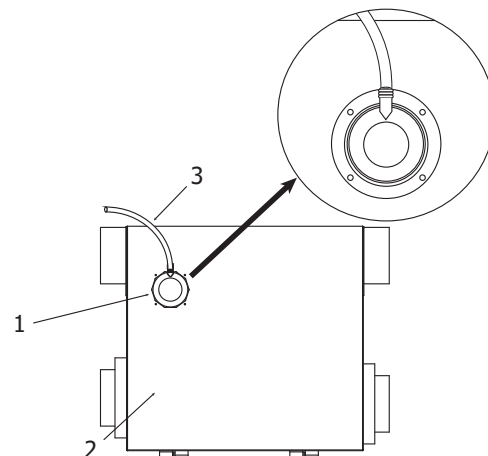

### CAUTION

- The HRV and all condensate lines must be installed in a space where the temperature is maintained above the freezing point or freeze protection must be provided.
- Drain trap and tubing must be below bottom of door with 1/4 in per foot downwards slope away from unit.
- A secondary drain pan may be required to protect from condensate leakage.

## Directions to Field Mirror the METRO 120ERV-ECM

The METRO 120ERV-ECM model with corded configuration, can be mirrored in the field by following steps 1 through 9.

Step 1: Open door of unit.

Step 2: Remove core from unit.

Step 3: Remove screw to swing open the EBOX (1).

Step 4: Reroute the thermistor through the opposite side of Ebox. There are two gromets located inside the EBOX compartment. Reroute the thermistor through the other grommet (2).

Step 5: Route the thermistor along the motor housing and down the side of the cabinet (3).

Step 6: Using a pencil or small screwdriver, poke a hole through the insulation where the hole is located on the metal core support (4).

Step 7: Feed the thermistor through the hole and position it so that approximately 2" is exposed past the insulation piece (5).

Step 8: Silicone around the hole where the thermistor is positioned.

Step 9: Swap the supply and exhaust motor connections from their default positions (6) so that the correct motor will shut off during defrost.

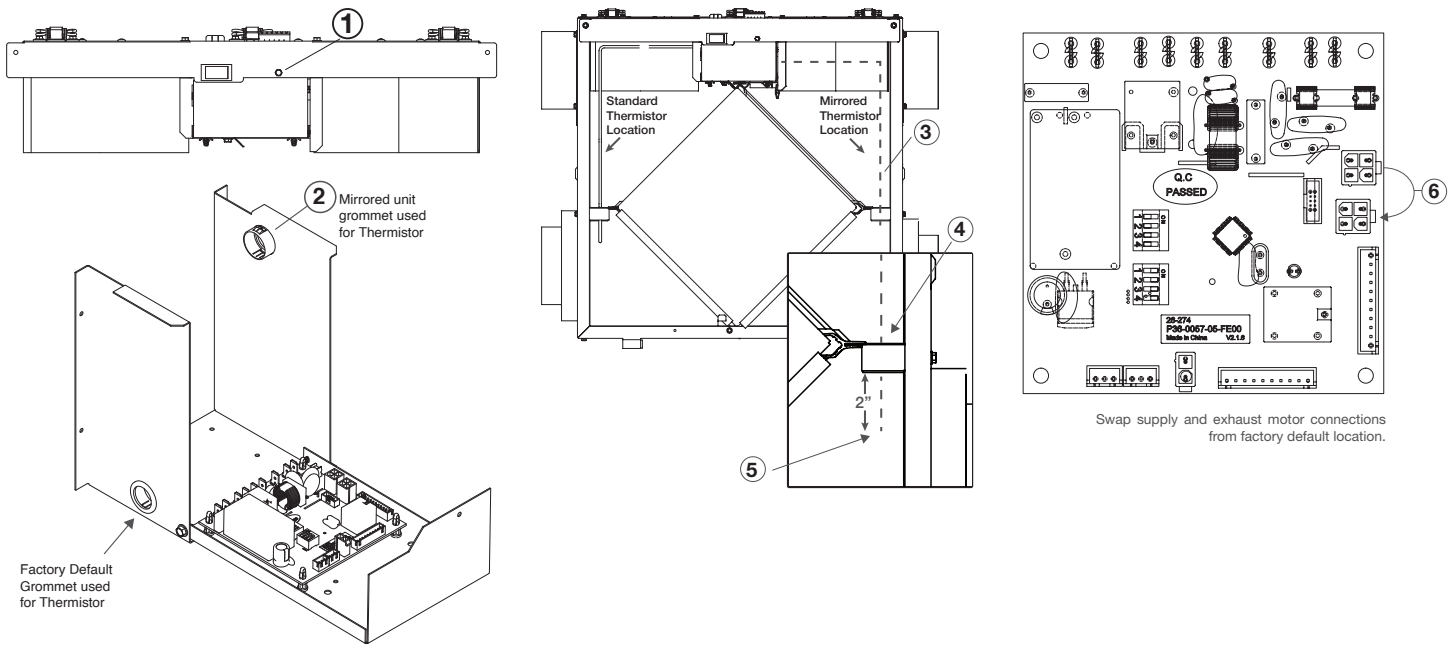

## Directions to Field Mirror the MAX XTR PLUS

POSITION 1

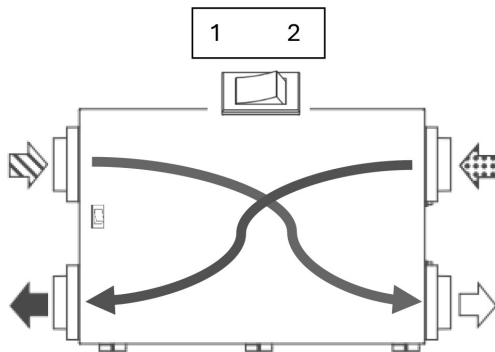

POSITION 2

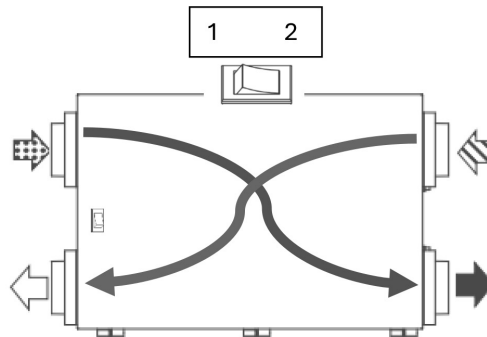

Position 2 requires jumper on TB04B connector

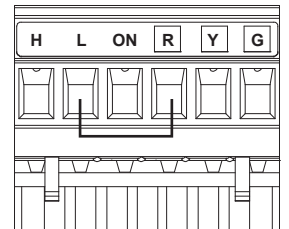

### Airflow:

⇨ Stale Air to Outside

⇨ Fresh Air from Outside

⇨ Stale Air from Inside

⇨ Fresh Air to Inside

# Grilles

## Installation Notes:

Adjustable grilles should be used to balance the flow rates into and out of various rooms. The grilles should not be adjusted after balancing the unit.

Grilles or diffusers should be positioned high on the wall or in the ceiling. Kitchen exhaust should never be connected to the range hood. They should be installed at least 4 ft (1.2 m) horizontally away from the stove.

Field supplied balancing dampers should be installed external to the unit to balance the amount of stale air being exhausted with the amount of fresh air being brought into the house. Refer to airflow balancing section.

## The Kitchen Grille

The Kitchen Grille includes a removable grease filter. Most building codes require that kitchen grilles are equipped with washable filters.

- Part# 99-10-002, 6 in x 10 in

Removable Filter

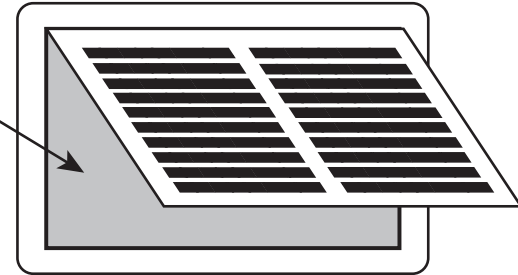

## The TechGrille

The TechGrille is a round, fully adjustable grille, which provides quiet air distribution.

- Part# 99-EAG4, 4 in (100 mm)
- Part# 99-EAG5, 5 in (125 mm)
- Part# 99-EAG6, 6 in (150 mm)
- Part# 99-EAG8, 8 in (200 mm)

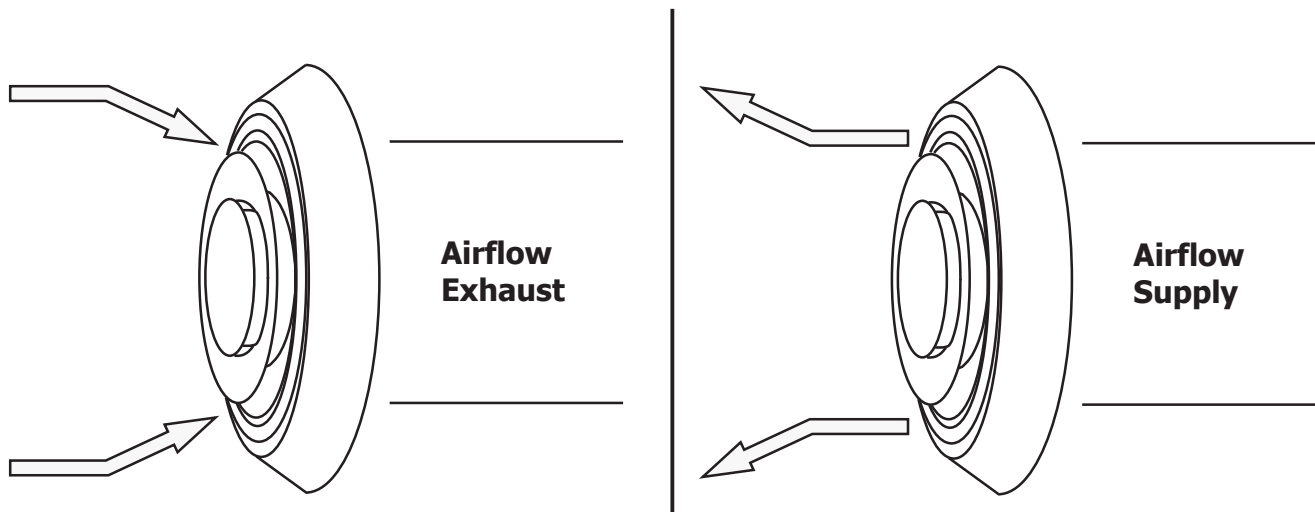

## Grille Fittings

### Quick Mount Fitting (Part# 99-QM6)

- Use this rough-in fitting before the drywall is installed.
- Nail fitting onto the stud.
- Available size: 6 in.

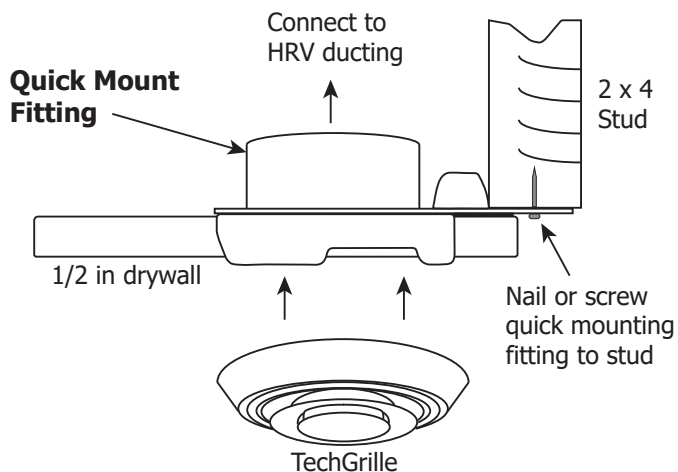

### Stack Head Elbow (Part# 99-WF 4/6)

- Use this rough-in fitting before the drywall is installed.
- This fitting is ideal for running ducting through 2 x 4 (min.) studded walls.
- Nail to stud.
- Available sizes are 4 in. and 6 in.

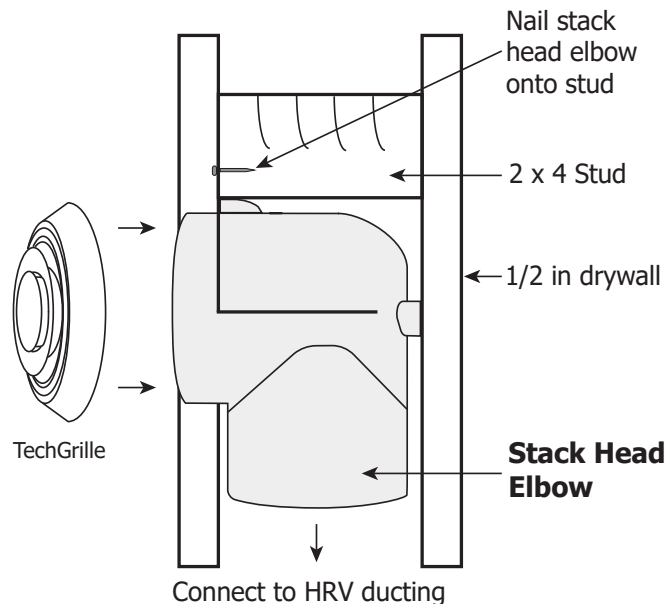

### Terminator Fitting (Part# 99-TM 4/5/6)

- Use this rough-in fitting before the drywall is installed.
- Nail or screw fitting onto the stud or joist.
- Available sizes: 4 in, 5 in, and 6 in.
- Adapts to ridged and flex ducting.
- Strong attachment for grilles, either vertically or horizontally.

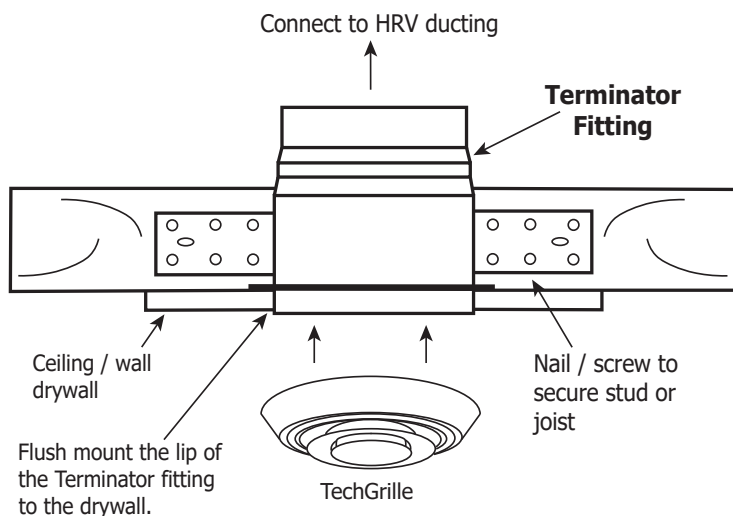

### Suspended Ceiling Fitting (Part# 99-CF6)

- Use this fitting for ceiling tiles or finished/installed drywall.
- Cut a hole through the ceiling tile, insert the fitting and use the retaining ring to hold the fitting in place.
- For finished/installed drywall, use caulking around the lip if you do not have access to attach the retaining ring.
- Available size: 6 in.

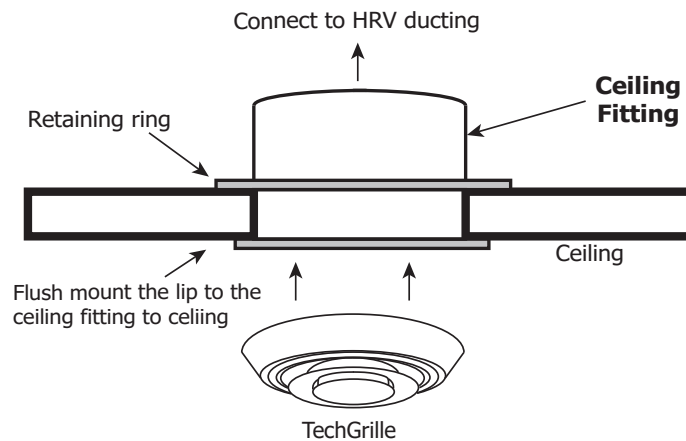

## ⚠ CAUTION

Do not mount exhaust grille within 4 ft (1.2 m) (horizontally) of a stove to prevent grease from entering the unit.

## Lifebreath Weather Hoods

Fixed covered weather hoods have a built-in bird screen with a 1/4 in. (6 mm) mesh to prevent foreign objects from entering the ductwork.

### Installation Notes:

- The inner and outer liners of the flexible insulated duct must be clamped to the sleeve of the weatherhoods (as close to the outside as possible) and the appropriate port on the HRV / ERV. It is very important that the fresh air intake line be given special attention to make sure it is well sealed. A good bead of high-quality caulking (preferably acoustical sealant) will seal the inner flexible duct to both the HRV / ERV port and the weatherhood prior to clamping.
- The flexible insulated duct that connects the two outside weatherhoods to the HRV / ERV should be stretched tightly and be as short as possible to minimize air flow restrictions.
- Twisting or folding the duct will severely restrict airflow.
- Hard (rigid) ducting which has been sealed and insulated should be used for runs over 10 ft (3.3 m). Refer to your local building code.

### Figure Callouts:

1. Thermal Collar
2. 12 in. long Galvanized Sleeve
3. Exterior Wall
4. 1/4 in. (6mm) Mesh Screen

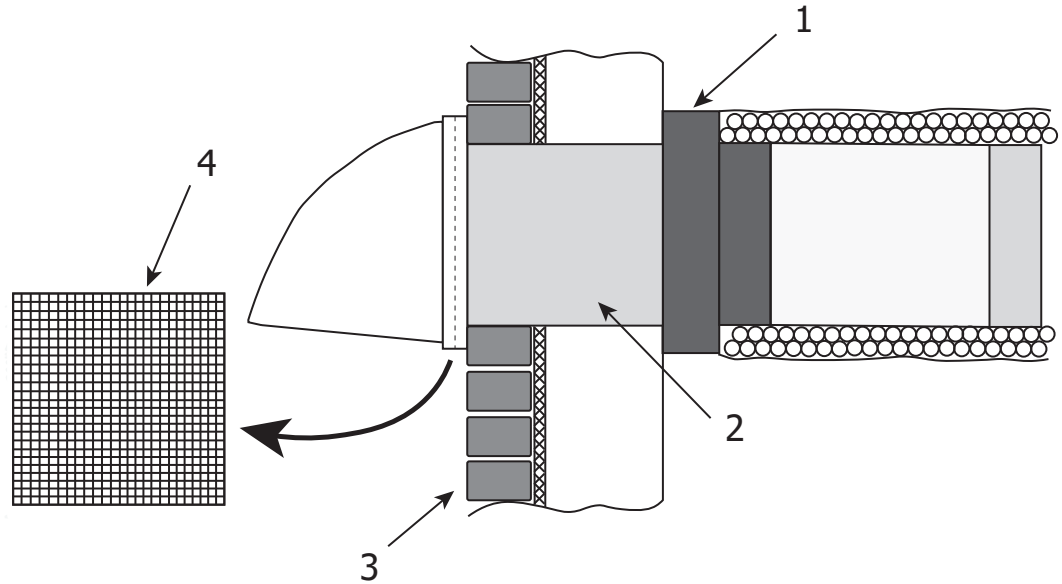

### Installation Steps:

1. Thermal collar slides over galvanized sleeve to ensure vapor barrier is 100% sealed to wall plate.
2. Fasten thermal collar to belt.
3. Slide the insulated flexible ducting over galvanized sleeve and fasten it to the thermal collar.
4. Weatherhood is hinged to allow for easy access for cleaning of mesh screen.

## ATTENTION

- **Weather Hood Requirements:** Check local codes/authority having jurisdiction for acceptance and space requirements for weatherhoods. Do not locate in garage, attic, or crawl space.
  - i. Intake: Should be located upstream (if there are prevailing winds) from the exhaust outlet. Not near dryer vents, furnace exhaust, driveways, oil fill pipes, gas meters, or garbage containers.
  - ii. Exhaust: Not near a gas meter, electric meter or a walkway where fog or ice could create a hazard.

# Dual Hood Kit

The Dual Hood Kit offers the benefit of requiring only one 6" (152 mm) hole in the exterior wall (as opposed to two separate weatherhoods) to complete the connections for fresh air intake and stale air exhaust. The pressure drop/airflow charts should be referred to when matching the Dual Hood to the HRV/ERV. The Dual Intake and Exhaust Hood Kit is compatible with 5" or 6" diameter duct.

Available Units:

- 99-194 – 4 in. Dual Hood (not shown)
- 99-190 – 5-6 in. Dual Hood

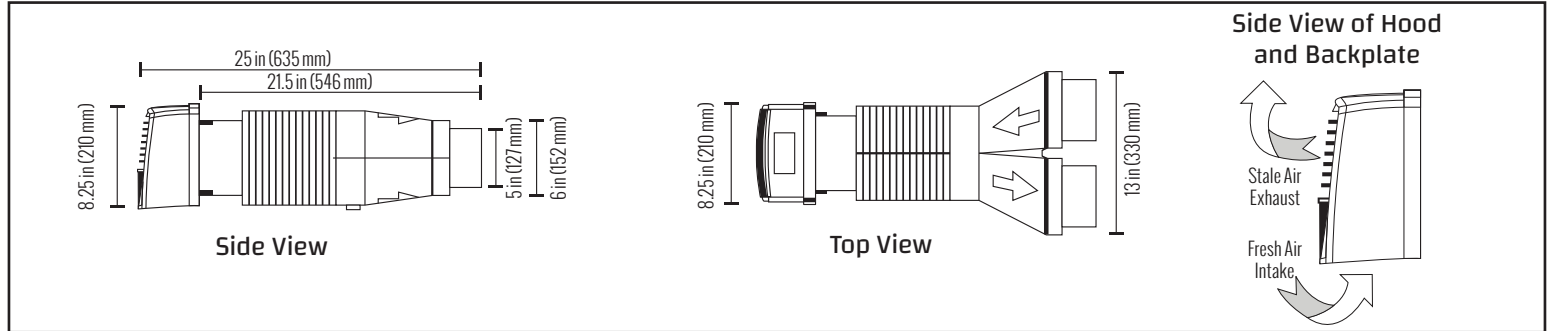

Figure 25. Dual Intake and Exhaust Hoods

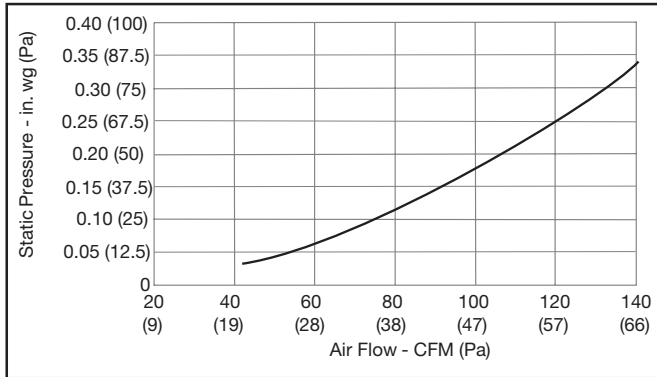

Figure 26. Intake Airflow Chart

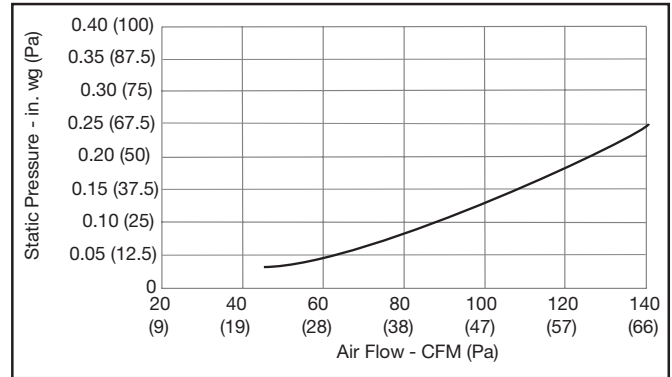

Figure 27. Exhaust Airflow Chart

## CAUTION

Follow installation instructions located in Dual Intake and Exhaust Hood kit. Contact your local building authority before installation of the Dual Intake and Exhaust Hood kit to verify compliance with local building codes.

- Sealant must be applied as per instructions or leakage and condensation may occur.
- Insulate the Fresh Air Supply and Stale Air Exhaust duct work back to the unit.

# Terminal Blocks

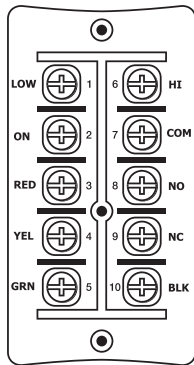

Figure 28. Type A

The METRO 120ERV, METRO 120D, METRO 120ERVD, & METRO 120F, have a TB01 Terminal Block.

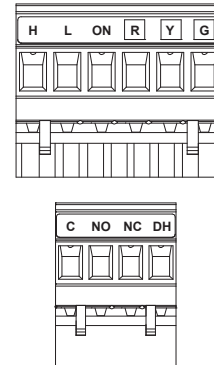

Figure 29. Type B

The METRO XTR, MAX XTR, MAX XTR PLUS, METRO 120ERV-ECM, METRO 120ERVD-ECM, METRO 120F-ECM, & METRO 120D-ECM, have a TB04 Terminal Block.

# Installation of Controls

The BC02, BC03, or BC04 Basic Controls may either be installed onto a flush mounted electrical switch box or surface mounted onto the wall. The DXPL03 Deluxe Control is to be surface mounted onto a wall. Only one control can be installed with a ventilation system.

- For the DXPL03 Deluxe Control, remove the operating instructions card from the top of the control (Figure 29, Box A).
- Separate the face plate from the back plate by firmly pulling apart (Figure 26, Boxes B or C). Be careful not to damage face plate contact pins.
- For the DXPL03 Deluxe Control, place the back plate of the control in the desired location on the wall and pencil mark the wall with the right and left screw holes (Figure 29, Box D).
- For the BC02, BC03, or BC04 Basic Controls, place the back plate of the control in the desired location on the wall and pencil mark the top and bottom screw holes (Figure 29, Boxes E or F). For mounting the control without a decorative plate, break off top and bottom tabs and refer to Figure 29, Box F for mounting.
- Remove the back plate from the wall and mark the center hole for the wires in the middle of the screw holes. Refer to Figure 29, Boxes D, E or F for dimensions.
- Drill (two) 1/8" (3 mm) holes for the screws and wall anchors (Figure 29, Boxes D, E or F). For the DXPL03 Deluxe Control, drill a one inch hole in the center (Figure 29, Box D). For the BC02, BC03, BC04 Basic Controls, cut in a 3/4" (19 mm) by 1" (25 mm) oval hole in the center (Figure 29, Boxes E or F).
- Pull 3-wire 20 gauge (minimum) 100 feet (30-1/2 meters) length (maximum), through the opening in the wall.
- Connect red, green, and yellow to the wiring terminals located on the back plate (Figure 29, Boxes D, E or F).
- Attach the back plate to the wall using two supplied screws and anchors.
- Attach the face plate to the back plate (Figure 29, Boxes B or C).
- NOTE: Be careful to correctly align the face plate to avoid damaging the face plate contact pins.
- For the DXPL03 Deluxe Control, insert the instructions card into the control (Figure 29, Box A).
- Connect the 3-wire 20 gauge (minimum) 100 feet (30-1/2 meters) length maximum to the terminal block located on ventilator (Red, Yellow, and Green).
- On the terminal block connect a jumper wire between ON and RED. Refer to "Installing Standby Jumper" on page 32.

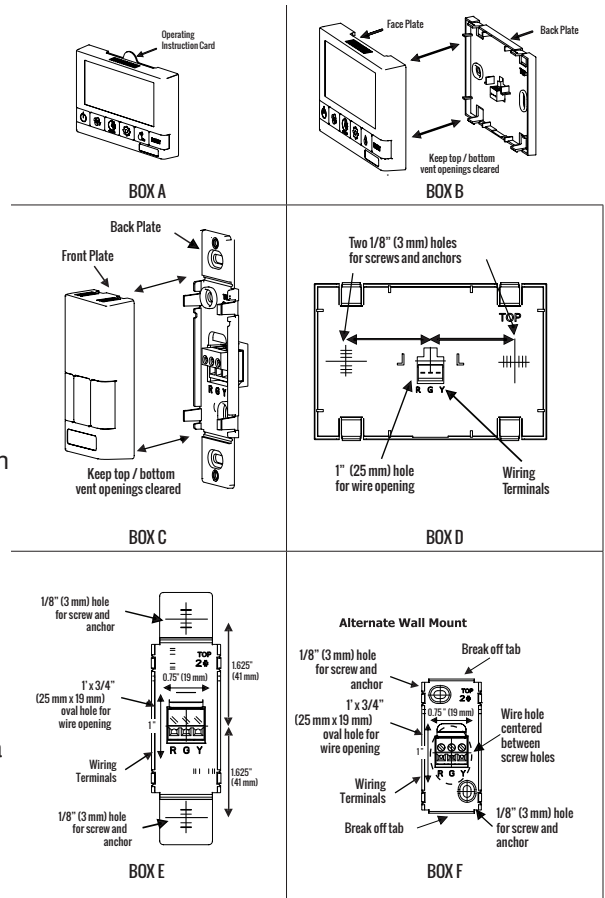

Figure 30. Installation of Controls

## ! IMPORTANT

Pay special attention not to damage the contact pins when removing and detaching the face plate.





# Installation and Operation of DET02 Wireless Timer

NOTE: DET02 Wireless timers can only be used with wall mounted BC02, BC03, BC04, DXPL02, or DXPL03 controls.

The DET02 wireless timers may be installed onto a flush mounted electrical switch box or it may be surface mounted onto a wall. Multiple DET02 wireless timers (maximum six timers) may be installed with ventilation system.

To increase the range of a DET02 wireless timer, a RX02 Repeater should be used.

## Pairing

1. Turn on the main wall control by pressing the ON/OFF button  and remove the battery from DET02 Wireless Timer.
2. **Pairing with DXPL02 or DXPL03 Deluxe Control:** Press the left and right buttons simultaneously on the control  and RESET buttons. The screen will go blank and the wireless symbol  appear flashing on the bottom right of the display. This indicates that the control is now in pairing mode (Figure 27, Box D).
3. **Pairing with BC02, BC03, or BC04 Basic Controls:** Press the left and right buttons simultaneously on the control buttons. The bottom row of three LEDs will begin flashing. This indicates that the main control is now in pairing mode (Figure 27, Box E).
4. Keep the timer within 16" (406 mm) of the control when pairing.
5. Install the battery in the DET02 Wireless Timer. All four lights on the timer will immediately flash five times, then only the red battery light will remain on for approximately 12 seconds after which the 40 light flashes. 20, 40, 60 lights will flash until paired or will stop if not paired within 12 seconds. If pairing was not successful you now must return to step 1 to restart the pairing process.
6. Press the  button on the control to exit pairing mode when wireless timers have been successfully paired.

Should Pairing be unsuccessful, please refer to to Unpairing Instructions on Page 30.

To pair additional DET02 wireless timers with the same wall control, or if pairing was not successful, repeat steps 1-6.

When paired, the DET02 wireless timers can be moved and installed elsewhere.

Estimated range of the DET02 wireless timer is 40' with no obstructions. A RX02 Repeater may be installed to increase the range of the DET02 Wireless Timer.

For BC02, BC03, or BC04 Basic Controls: To test if the pairing was successful, ensure the unit is in low speed then press the button on the DET02 Wireless Timer and listen for the HRV/ERV to initiate HIGH fan speed ventilation.

For DXPL02 and DXPL03 Deluxe Control: To test if the pairing was successful press the button on the DET02 Wireless Timer and look for the wireless symbol  to display on the LED screen next to the fan speed.

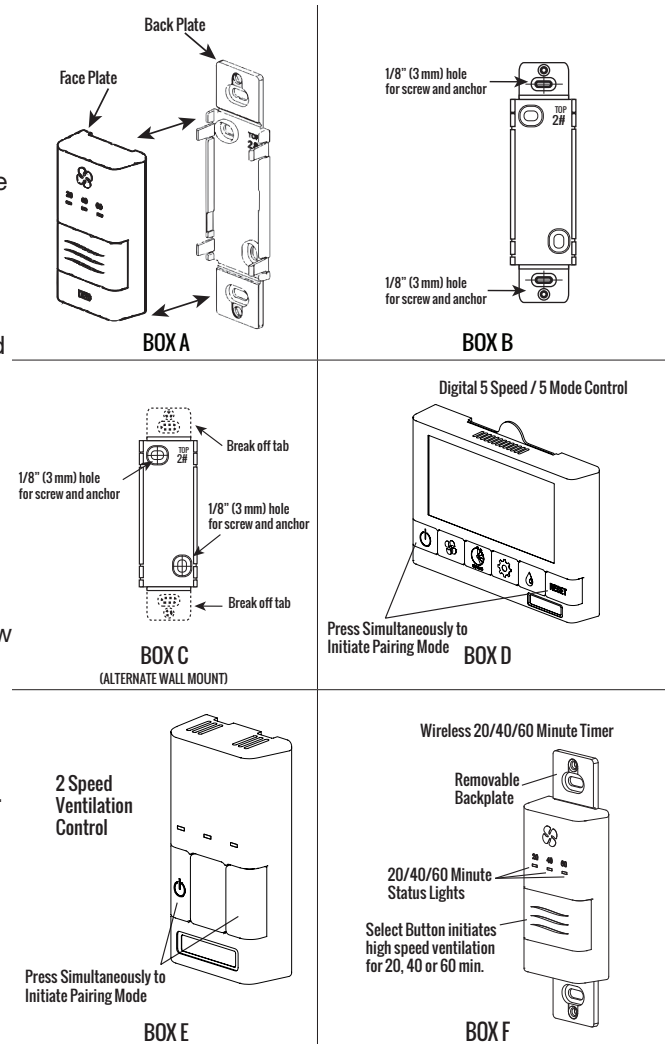

Figure 31. Installation of Timer

## Installation and Operation of DET02 Wireless Timer (continued)

### Unpairing

1. Remove the battery from the back of the wireless timer.
2. Press and hold the button on the front of the DET02 Wireless Timer.
3. While holding the button, reinsert the battery in the DET02 Wireless Timer. Continue holding the button, until all lights on the DET02 Wireless Timer stop flashing. The DET02 Wireless Timer will now be unpaired with the control.

Note: Use this procedure when the pairing procedure is not working to factory-reset the wireless timer.

### Installation

1. Separate the face plate from the back plate by firmly pulling apart (Figure 27, Box A).
2. For mounting the control without a decorative plate, break off top and bottom tabs and refer to Figure 30, Box C for mounting.
3. Place the back plate of the control in the desired location on the wall and pencil mark the top and bottom screw holes (Figure 27, Boxes B or C). Drill two 1/8" (3 mm) holes.
4. Attach the back plate to the wall using the two supplied screws and anchors.
5. Attach the face plate to the back plate (Figure 27, Box F).









### IMPORTANT

The wireless timers and RX02 Repeater must be paired to the wall control of the ERV. Multiple Timers and RX02 Repeater can be paired to a single wall control.

## Installation and Pairing of RX02 Repeater

A RX02 Repeater may be necessary if the distance of the DET02 Wireless Timer is too great to communicate directly with the control. The RX02 Repeater is plugged directly into a 120V power outlet.

1. Turn on the main wall control by pressing the ON/OFF button .
2. Pairing RX02 Repeater with DXPL03 Deluxe Control: Press the left and right buttons simultaneously on the main wall control  and RESET buttons. The screen will go blank and the wireless  symbol will appear flashing on the bottom right of the display. This indicates that the control is now in pairing mode.
3. Pairing RX02 Repeater with BC02, BC03, or BC04 Basic Control: Press the left and right buttons simultaneously on the control , , and . The bottom row of three LED's will begin flashing. This indicates that the control is now in pairing mode.
4. The RX02 Repeater must be powered within 16" (406 mm) of the control for pairing. If an outlet is not available an extension cord should be used to power the RX02 Repeater during pairing.
5. Plug the RX02 Repeater into the power outlet. The green light will flash after approximately 12 seconds indicating that the RX02 Repeater is paired with the control.
6. Press the  button on the control to exit pairing mode and the RX02 Repeater may now be unplugged and moved to its permanent location midway between DET02 Wireless Timer and Control.

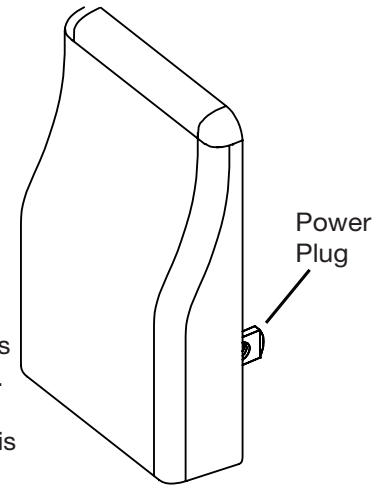

Figure 32. Wireless Repeater

To pair additional RX02 Repeater with the same control, repeat steps 1-5 until all RX02 Repeaters have been paired.

When installed in its permanent location, the green LED will indicate the quality of communication with the wall control. See Table 12 below.

Table 12. Wireless Range Extender LED Indication

LED Indication	Quality of Communication
Solid green	Best
Flashing green	Good
Solid Red	Bad

# Installation and Operation of DET01 Timer

## Installation Requirements

The following installation requirements must be followed:

- Timers mount in standard 2 x 4" (51 x 102 mm) electrical boxes.
- If multiple timers are used, individually wire each timer to the unit.
- Use 3-wire 20-gauge (min.) low-voltage wire.

## Lockout Mode

The timer can be set to lockout mode (timers disabled) as follows: press and hold the button for five seconds; the status lights will flash; then release the button. The timer is now in lockout mode.

If the button is pressed during lockout mode, the status lights will momentarily illuminate but no override will be initiated. If lockout mode is initiated when the timer is activated, the timer will continue its timed sequence but will not allow any further overrides to be initiated.

To unlock lockout mode, press and the button for five seconds; until the high-speed status lights stop flashing; then release the button. The timer will now operate normally.

**Recommendation:** Use shielded wire to reduce communication noise.

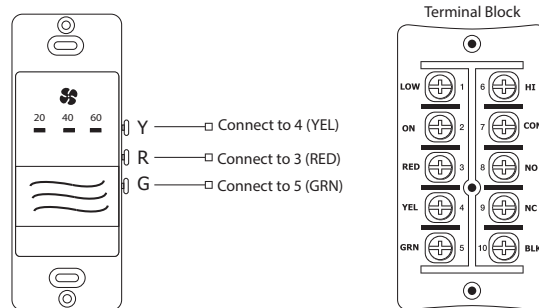

Figure 33. DET01 Timer with Type A terminal block

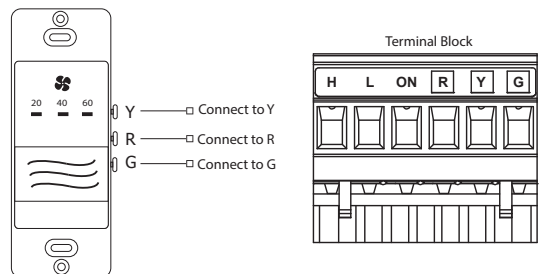

Figure 34. DET01 Timer with Type B terminal block

## Installation of Third Party Mechanical Timers

The HRV/ERV is compatible with two wire, "dry contact" third party mechanical timers. This may be useful for retrofit situations where only two wires are available for the timer.

Install the two wire timer by connecting a jumper wire between ON and RED. Connect the two timer wires to ON and HI.

NOTE: An alternative to using the 2-wire timers is to install the system with wireless timers.

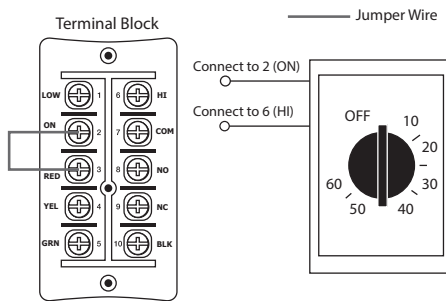

Figure 35. Dry Contacts Connections with Type A terminal block

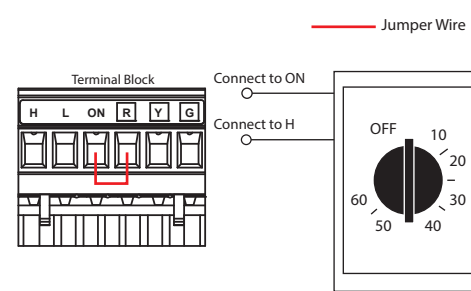

Figure 36. Dry Contacts Connections with Type B terminal block

## Interlocking HRV/ERV to Air Handler/Furnace Blower

Connecting the HRV/ERV unit as illustrated will ensure the air handler/furnace blower motor is operating whenever the HRV/ERV is ventilating.

The HRV/ERV unit must be interlocked to the furnace/air handler with a simplified (return/return) installation and a partially dedicated installation as illustrated in the following figure.

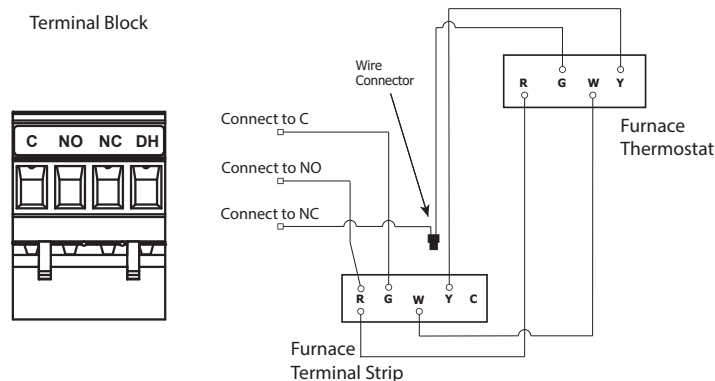

Figure 37. Air Handler/Furnace Blower Connections with Type B Terminal Block

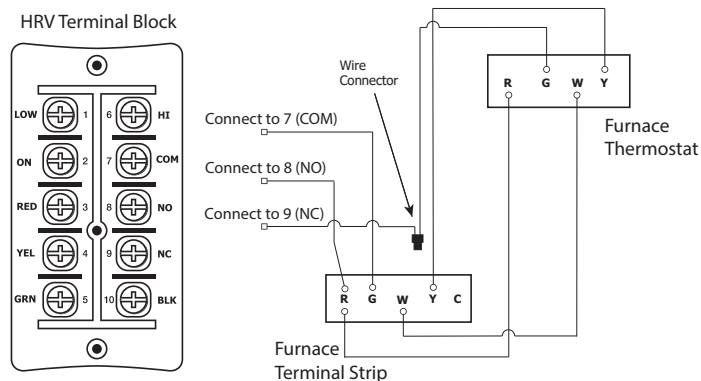

Figure 38. Air Handler/Furnace Blower Connections with Type A Terminal Block

# Electrical Connections

Plug the HRV/ERV directly into a standard designated 120VAC electrical outlet. Use of an extension cord is NOT RECOMMENDED for this appliance.

If further wiring is required, then a licensed electrician should make all electrical connections. It is recommended that a separate 15A/120V circuit be used. See wiring diagrams for the units described in section titled "Unit Wiring Diagrams" on pages 33 - 34.

## ! IMPORTANT

### Electric Shock Hazard

Can cause injury or death.

Confirm the polarity of the 120VAC supply source at the receptacle for the HRV/ERV device. The door safety switch of the HRV/ERV can cause an electrical shock hazard if the polarity is not properly wired. The grounding means of the HRV/ERV device should also be confirmed. The proper polarity and ground can be checked at the receptacle using a 3-prong plug device called a 'polarity tester'. Another method to check for proper polarity is to use a volt-ohm meter to check for voltage from line voltage to ground (chassis) at the HRV/ERV.

### Installing "Standby" Jumper

A jumper must be installed between the ON and R terminals to change the default OFF setting from "fully-OFF" to "standby-OFF". Timers will continue to initiate high speed ventilation while unit is in "standby-OFF" with the exception of the DET02 Wireless Timer.

The HRV/ERV will be "fully-OFF" when OFF is selected on the main control and no jumper is installed between the ON and R terminals. Timers and/or controls will not function when the HRV/ERV is "fully-OFF".

On the DXPL03 Deluxe Control "standby-OFF" can be achieved by setting the control to ON and selecting speed 0. Timers will initiate high speed ventilation when activated.

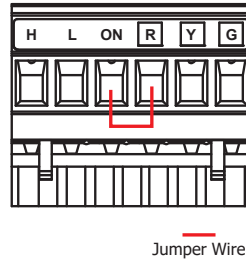

Figure 39. Low Speed Ventilation

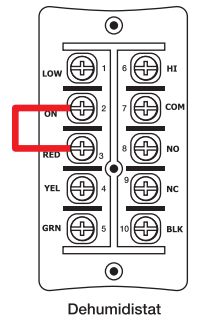

Figure 40. High Speed Ventilation

## ! CAUTION

Building codes in some areas require fully-off functionality. Check with your local building authority before modifying the unit to standby-off. Unintentional operation of the ERV by the end user may occur if the unit is modified from fully-off to standby-off.

### Activating Dry Contact Controls

Dry contact connections can be used to connect any third party controls or simple wire jumpers can be used. Dry contacts will engage continuous low speed ventilation, continuous high speed ventilation, or dehumidification. See Table 12 below. The dehumidification dry contact will be disabled in accordance with the dehumidification disable function (see page 12).

The NO NC and COM connections are a relay that switches when the fans are turned on or off. These connections can be used to control third party devices such as motorized dampers.

Note: contacts NO, NC and COM can only receive a 12 V signal.

#### Exception: MAX XTR PLUS

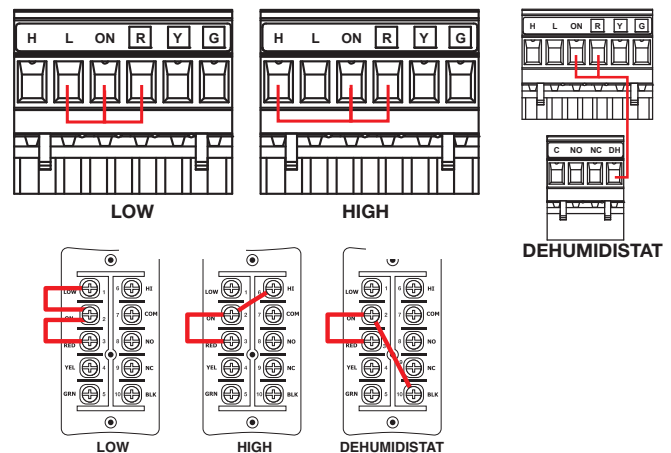

Figure 41. Dry Contact Controls

Table 13. Dry Contacts

Speed	Description
Low speed	A jumper between 2 (ON) and 1 (LOW) initiates low speed ventilation.
High speed	A jumper between 2 (ON) and 6 (HI) initiates high speed ventilation.
Dehumidistat	A dry contact for a dehumidistat is connected between 2 (ON) and 10 (BLK).

## ! IMPORTANT

The ERV must have a jumper in place between 2 (ON) and 3 (RED) on the Terminal Block when installing the unit without a Control.

# Unit Wiring Diagrams

Applicable units prior to 021826 (MMDDYY):  
METRO 120ERV, METRO 120F, & METRO XTR

**CAUTION: ELECTRICAL CONTROL PANEL, SERVICE BY ELECTRICIAN ONLY**

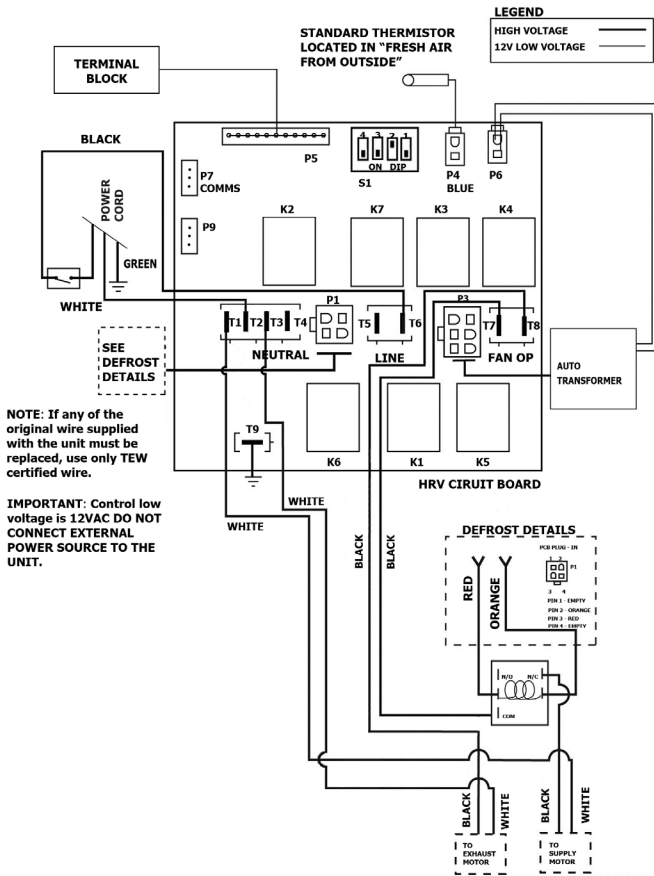
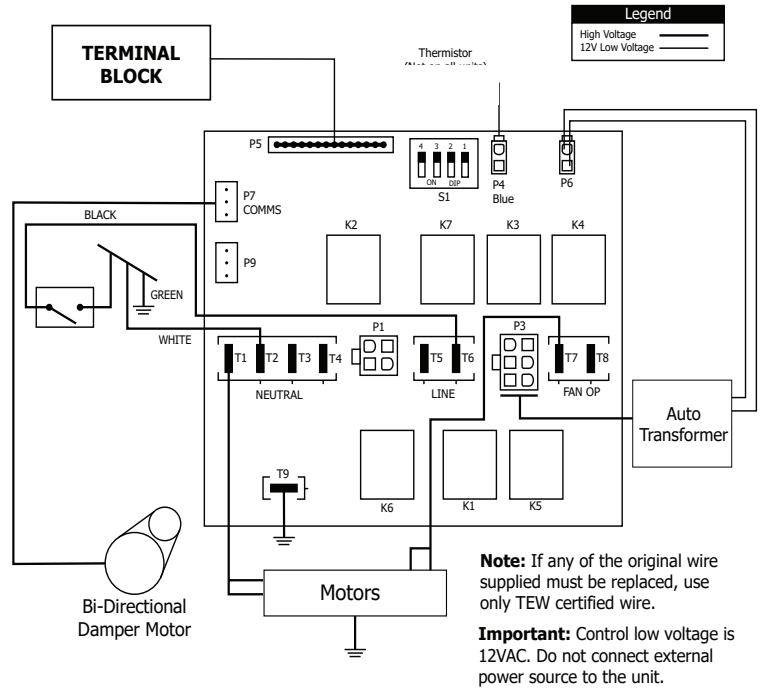

Figure 42. Wiring Diagram

Applicable units prior to 021826 (MMDDYY):  
METRO 120D & METRO 120ERVD

**CAUTION: ELECTRICAL CONTROL PANEL, SERVICE BY ELECTRICIAN ONLY**



59-TPD-3SP  
NEW2023

Figure 43. Wiring Diagram

Applicable units post 021826 (MMDDYY):  
METRO 120ERV/M, METRO 120F, METRO XTR,  
METRO 120D & METRO 120ERVD/M

**CAUTION: ELECTRICAL CONTROL PANEL, SERVICE BY ELECTRICIAN ONLY**

Note: If any of the original wires supplied must be replaced, use only TEW certified wire.  
Important: Control wiring low voltage 12VAC.  
Do not connect external power source to the unit.

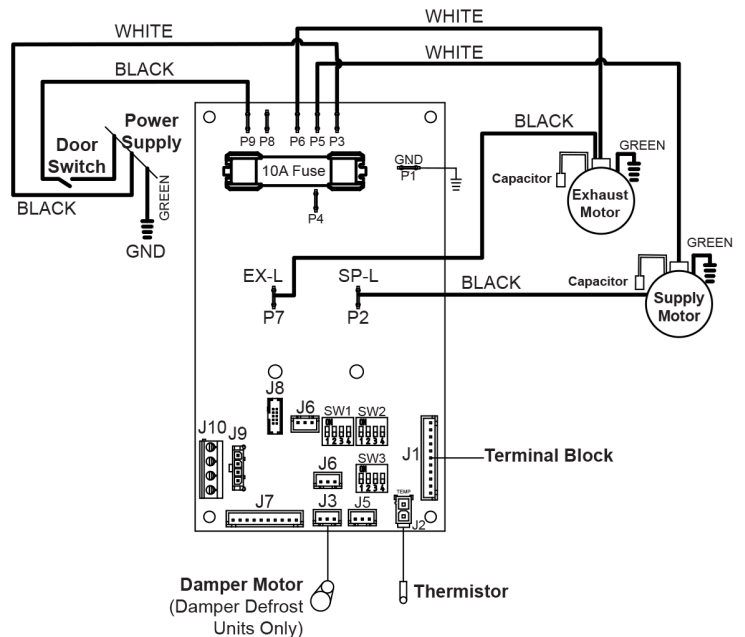
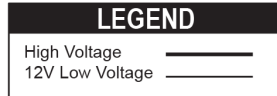

# Unit Wiring Diagrams

Applicable Unit: MAX XTR, METRO 120ERV-ECM, METRO 120ERVD-ECM, METRO 120F-ECM, METRO 120D-ECM

**CAUTION: ELECTRICAL CONTROL PANEL, SERVICE BY ELECTRICIAN ONLY**

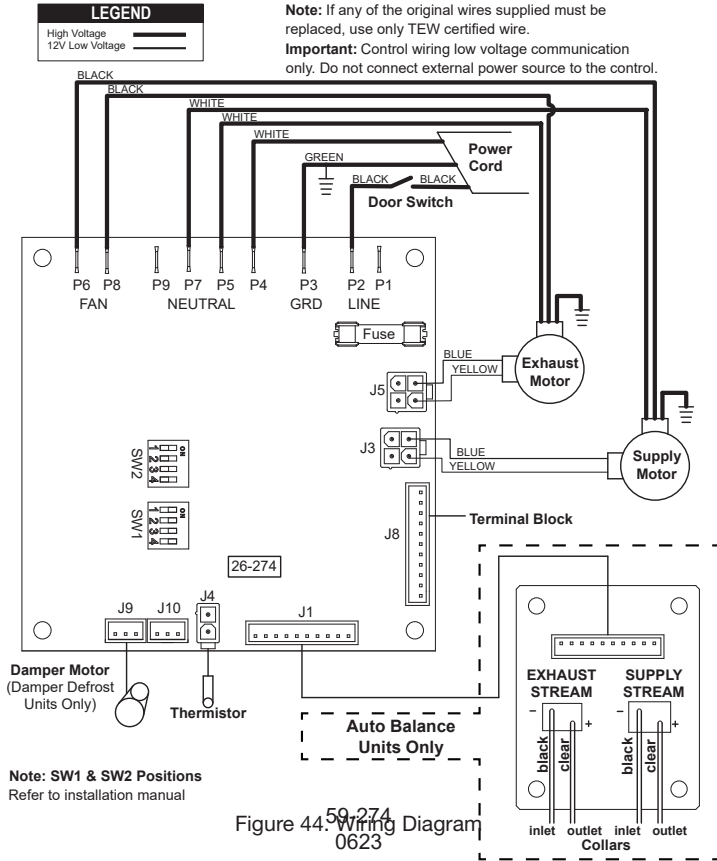

Applicable Unit: MAX XTR-FID, METRO 120F-ECM-FID, METRO 120 ERV-ECM-FID

**CAUTION: ELECTRICAL CONTROL PANEL, SERVICE BY ELECTRICIAN ONLY**

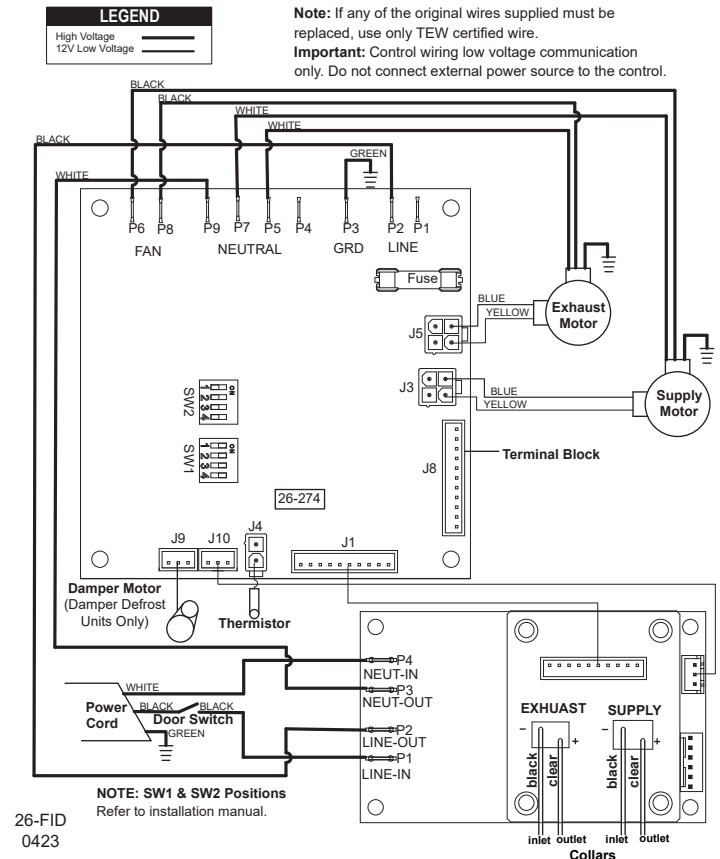

Applicable Unit: MAX XTR PLUS

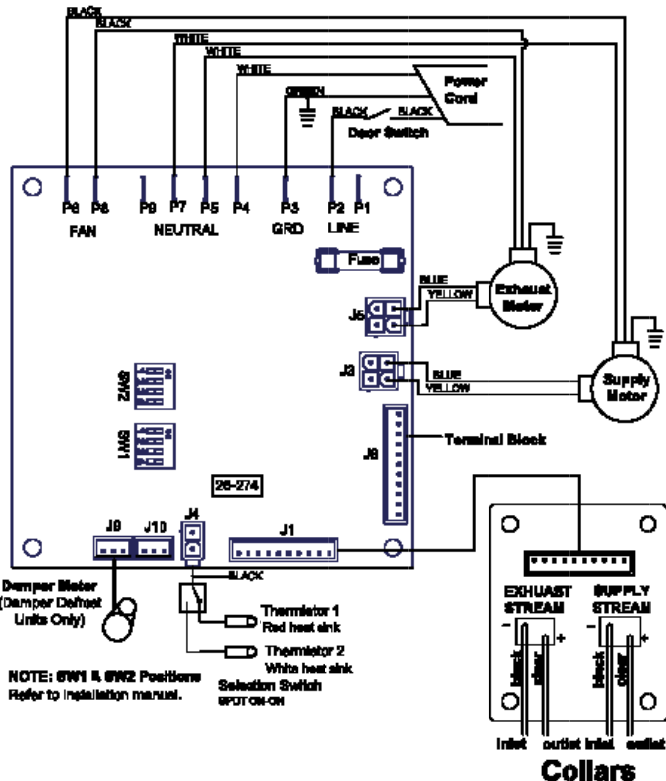

**CAUTION: ELECTRICAL CONTROL PANEL, SERVICE BY ELECTRICIAN ONLY**

**Note:** If any of the original wires supplied must be replaced, use only TEW certified wire.  
**Important:** Control wiring low voltage communication only. Do not connect external power source to the control.



# Unit Dip Switch Orientation

Applicable Units: MAX-XTR, METRO 120 ERV-ECM, METRO 120 ERVD-ECM, METRO 120F-ECM, METRO 120D-ECM, METRO 120ERV-ECM-AB, METRO 120ERV-ECM-FID, METRO 120F-ECM-AB, METRO 120F-ECM-FID

The circuit board on the units have adjustable DIP switches to select the maximum air flow at high speed. Adjusting high speed can be useful to accurately satisfy the calculated ventilation rate. The table below indicates how to adjust high speed to speed 4 (Hi 2) and speed 3 (Hi 1). Refer to the specification pages in the manual for the air flow rates for speeds 5, 4 and 3. The factory setting is speed 5 (Hi 3).

**Table 14. DIP Switch Configuration – General Information**

First 6 digits of Unit Serial Number (MMDDYY)	Switch 1	Switch 2		
Prior to 092123	All four DIPs Unit Selection	DIP 1 ON: R2000 Defrost cycle disabled; DIP 1 OFF: R2000 Defrost cycle enabled; DIP 2 ON: FID enabled; DIP 2 OFF: FID disabled; DIP 3 and 4: Selectable High Speed*		
		* Selectable High Speed		
		Speed	DIP 3	DIP 4
		Hi 3 (Speed 5)	ON	ON
		Hi 2 (Speed 4)	OFF	ON
		Hi 1 (Speed 3)	ON	OFF
Post 092123	All four DIPs Unit Selection	DIP 1 ON: R2000 Defrost cycle disabled; DIP 1 OFF: R2000 Defrost cycle enabled; DIP 2 ON: FID enabled; DIP 2 OFF: FID disabled;		

**Table 15. DIP Switch Configuration – Factory Settings**

Model Name	First Character of Serial Number Alpha Code*	Second Character of Serial Number Alpha Code*	First 6 digits of Unit Serial Number (MMDDYY)*	Switch 1				Switch 2			
				DIP 1	DIP 2	DIP 3	DIP 4	DIP 1	DIP 2	DIP 3	DIP 4
MAX-XTR	F	A or '-'	Post 092123	OFF	ON	OFF	OFF	ON	OFF	ON	ON
		F	Post 092123	OFF	ON	OFF	OFF	ON	ON	ON	ON
	B	A or '-'	Post 092123	OFF	ON	OFF	OFF	ON	OFF	ON	OFF
		F	Post 092123	OFF	ON	OFF	OFF	ON	ON	ON	OFF
	E	A or '-'	Post 092123	OFF	ON	OFF	OFF	ON	OFF	OFF	ON
		F	Post 092123	OFF	ON	OFF	OFF	ON	ON	OFF	ON
	F	A or '-'	Prior to 092123	ON	ON	OFF	OFF	ON	OFF	ON	ON
		F	Prior to 092123	ON	ON	OFF	OFF	ON	ON	ON	ON
	B	A or '-'	Prior to 092123	OFF	OFF	OFF	ON	ON	OFF	ON	ON
		F	Prior to 092123	OFF	OFF	OFF	ON	ON	ON	ON	ON
	E	A or '-'	Prior to 092123	OFF	OFF	OFF	OFF	ON	OFF	ON	ON
		F	Prior to 092123	OFF	OFF	OFF	OFF	ON	ON	ON	ON
	E	A	Post to 092123	ON	OFF	OFF	OFF	ON	OFF	ON	ON

**Note:** Replacement circuit boards will follow the post-092123 DIP switch configuration

# Unit Dip Switch Orientation

Table 15. DIP Switch Configuration – Continued

Model Name	First Character of Serial Number Alpha Code*	Second Character of Serial Number Alpha Code*	First 6 digits of Unit Serial Number (MMDDYY)*	Switch 1				Switch 2			
				DIP 1	DIP 2	DIP 3	DIP 4	DIP 1	DIP 2	DIP 3	DIP 4
METRO 120 ERV-ECM	F	A or '-'	Post 092123	OFF	OFF	OFF	OFF	ON	OFF	ON	ON
		F	Post 092123	OFF	OFF	OFF	OFF	ON	ON	ON	ON
	B	A or '-'	Post 092123	OFF	OFF	OFF	OFF	ON	OFF	ON	OFF
	E	A or '-'	Post 092123	OFF	OFF	OFF	OFF	ON	OFF	OFF	ON
	F	-	Prior to 092123	OFF	OFF	ON	ON	ON	OFF	ON	ON
	B	-	Prior to 092123	ON	ON	ON	ON	ON	OFF	ON	ON
METRO 120 ERVD-ECM	F	-	Post 092123	OFF	OFF	OFF	ON	ON	OFF	ON	ON
	B	-	Post 092123	OFF	OFF	OFF	ON	ON	OFF	ON	OFF
	E	-	Post 092123	OFF	OFF	OFF	ON	ON	OFF	OFF	ON
	F	-	Prior to 092123	ON	ON	OFF	ON	ON	OFF	ON	ON
	B	-	Prior to 092123	OFF	ON	ON	ON	ON	OFF	ON	ON
METRO 120F - ECM	F	A or '-'	Post 092123	OFF	OFF	ON	OFF	ON	OFF	ON	ON
		F	Post 092123	OFF	OFF	ON	OFF	ON	ON	ON	ON
	B	A or '-'	Post 092123	OFF	OFF	ON	OFF	ON	OFF	ON	OFF
	F	-	Prior to 092123	OFF	ON	OFF	ON	ON	OFF	ON	ON
	B	-	Prior to 092123	ON	OFF	ON	ON	ON	OFF	ON	ON
METRO 120D - ECM	F	-	Post 092123	OFF	OFF	ON	ON	ON	OFF	ON	ON
	B	-	Post 092123	OFF	OFF	ON	ON	ON	OFF	ON	OFF
	E	-	Post 092123	OFF	OFF	ON	ON	ON	OFF	OFF	ON
	F	-	Prior to 092123	ON	OFF	OFF	ON	ON	OFF	ON	ON
	B	-	Prior to 092123	ON	ON	ON	OFF	ON	OFF	ON	ON
MAX XTR PLUS	F	A	Post 092123	ON	OFF	OFF	OFF	ON	OFF	ON	ON

Note: Replacement circuit boards will follow the post-092123 DIP switch configuration

# Unit Dip Switch Orientation

Applicable Units: METRO-120F, METRO-120ERV/M, METRO-120D, METRO-120D, METROERV/D/M.

**Table 16. DIP Switch Configuration - General Information**

First 6 digits of Unit Serial Number (MMDDYY)	Switch 1			Switch 2			Switch 3
Prior to 021826	DIP 1 ON: R2000 Defrost cycle disabled; DIP 1 OFF: R2000 Defrost cycle enabled DIP 2 ON: Recirculation Enabled (damper defrost models only); DIP 2 OFF: Recirculation Disabled (fan defrost models only); DIP 3 and 4: Selectable High Speed*			-			-
	* Selectable High Speed						
	Speed	DIP 3	DIP 4				
	Hi 3 (Speed 5)	ON	ON				
	Hi 2 (Speed 4)	OFF	ON				
	Hi 1 (Speed 3)	ON	OFF				
Prior to 021826	All four DIPs Unit Selection			DIP 1 ON: R2000 Defrost cycle disabled; DIP 1 OFF: R2000 Defrost cycle enabled DIP 2 ON: FID enabled; DIP 2 OFF: FID disabled; DIP 3 and 4: Selectable High Speed*			DIP 1, 2, 3 and 4 - Null
				* Selectable High Speed			
				Speed	DIP 3	DIP 4	
				Hi 3 (Speed 5)	ON	ON	
				Hi 2 (Speed 4)	OFF	ON	
				Hi 1 (Speed 3)	ON	OFF	
	Hi 0 (Speed 2)	OFF	OFF				

**Table 17. DIP Switch Configuration - Factory Settings**

	First 6 digits of Unit Serial Number (MMDDYY)*	Switch 1				Switch 2				Switch 3			
		DIP 1	DIP 2	DIP 3	DIP 4	DIP 1	DIP 2	DIP 3	DIP 4	DIP 1	DIP 2	DIP 3	DIP 4
<b>METRO 120F</b>	Prior to 021826	ON	OFF	ON	ON	n.a.	n.a.	n.a.	n.a.	n.a.	n.a.	n.a.	n.a.
<b>METRO 120F</b>	Post 021826	ON	OFF	OFF	ON	ON	ON	ON	ON	ON	ON	ON	ON
<b>METRO 120ERV/M</b>	Prior to 021826	ON	OFF	ON	ON	n.a.	n.a.	n.a.	n.a.	n.a.	n.a.	n.a.	n.a.
<b>METRO 120ERV/M</b>	Post 021826	ON	OFF	ON	OFF	ON	ON	ON	ON	ON	ON	ON	ON
<b>METRO XTR</b>	Prior to 021826	ON	OFF	ON	ON	n.a.	n.a.	n.a.	n.a.	n.a.	n.a.	n.a.	n.a.
<b>METRO XTR</b>	Post 021826	ON	OFF	OFF	OFF	ON	ON	ON	ON	ON	ON	ON	ON
<b>METRO 120D</b>	Prior to 021826	ON	ON	ON	ON	n.a.	n.a.	n.a.	n.a.	n.a.	n.a.	n.a.	n.a.
<b>METRO 120D</b>	Post 021826	ON	OFF	OFF	ON	OFF	ON	ON	ON	ON	ON	ON	ON
<b>METRO 120ERV/D/M</b>	Prior to 021826	ON	ON	ON	ON	n.a.	n.a.	n.a.	n.a.	n.a.	n.a.	n.a.	n.a.
<b>METRO 120ERV/D/M</b>	Post 021826	ON	OFF	ON	OFF	OFF	ON	ON	ON	ON	ON	ON	ON

**Note:** Replacement circuit boards will follow the post-092123 DIP switch configuration

## Balancing the Airflows

Balancing the airflows is critical to ensure that the amount of air coming into the building equals the amount of air exhausted to the outside of the building. If these two airflows are not properly balanced, the following issues may occur:

A positive or negative pressure in the house

- HRV/ERV will not operate at its maximum efficiency
- HRV/ERV will not defrost properly

The METRO 120ERV, METRO 120ERVD, METRO 120ERV-ECM, METRO 120ERVD-ECM, METRO 120F, METRO 120D, METRO 120F-ECM, & METRO 120D-ECM are considered “factory balanced”. Due to the design of the unit, if the supply and exhaust static pressure of the duct installation are within 0.3 (in w.g.) of each other, the supply and exhaust airflows will be within 10% of each other. These units, therefore, do not require balancing during installation if these conditions are met. If these conditions are not met then follow the manual balancing procedure below.

The METRO XTR, METRO 120 ERV-ECM-AB, METRO 120ERV-FID, METRO 120F-ECM-AB, or METRO 120F-ECM-FID should be balanced using the Collar Port Method. See page 41.

The MAX XTR & MAX XTR PLUS should be balanced using the Auto Balance feature of the DXPL03 Deluxe Control.

## Manual Balancing

**Airflow Measuring Gauge:**

A digital manometer is a suitable instrument for the balancing of airflows.

**Gauge Attachments:**

When sampling an airflow, various attachments are available for use on a digital manometer. The illustration below shows a digital manometer with a pitot tube attachment. This combination will measure the system air velocity pressure accurately, regardless of the duct size or shape (either round or rectangular).

**Balancing Preparation:**

Prior to performing the air balancing procedure, perform the following steps:

1. Seal the ductwork.
2. Confirm the installation and proper operation of all the components of the HRV/ERV.
3. Fully open the balancing dampers.
4. Turn off all household exhaust devices (range hood, clothes dryer, bathroom fans).
5. Set the system at high speed.
6. Prior to balancing the unit, first adjust airflows in the branch lines to specific areas of the house.
7. If the outdoor temperature is below 0°C (32°F), ensure the unit is not running in defrost.
8. If the system is a Simplified or Partially Dedicated installation, operate the furnace/air handler at high speed.

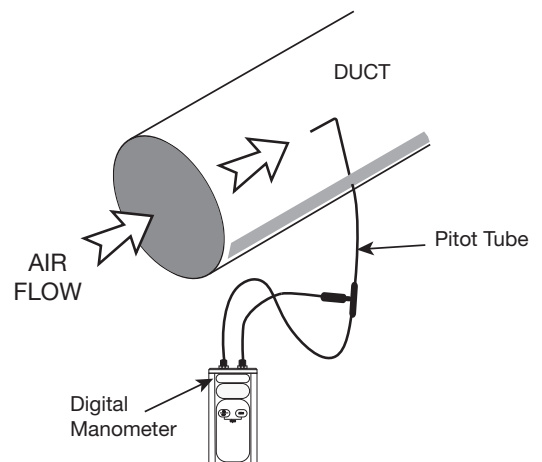

Figure 46. Manual Balancing



### ATTENTION

Continuous, excessive, positive pressure may drive moist indoor air into the external walls of the building. Once inside the external walls, moist air may condense (in cold weather) and degrade structural components or cause locks to freeze. Continuous, excessive, negative pressure may have several undesirable effects. In some geographic locations, soil gases such as methane and radon gas may be drawn into the home through basement or ground contact areas and may also cause the backdrafting of vented combustion equipment.

## Manual Balancing (continued)

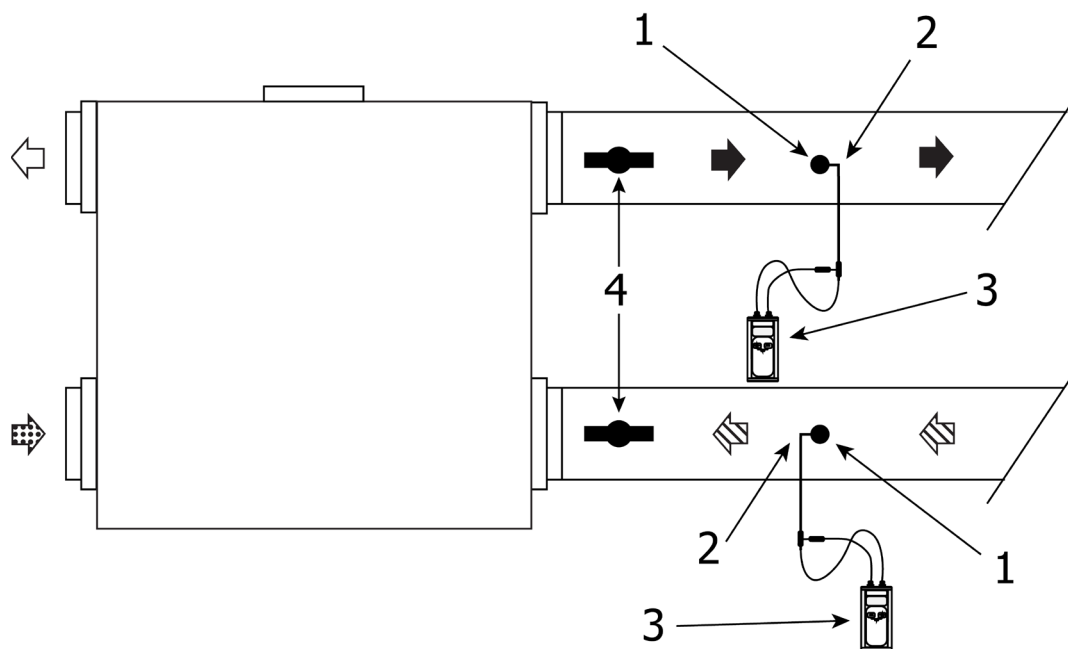

### Airflow:

- Stale Air to Outside
- Fresh Air from Outside
- Stale Air from Inside
- Fresh Air to Inside

### Figure Callouts:

- 1. 3/16 in. Hole
- 2. Pitot Tube Tip
- 3. Digital Manometer
- 4. Balancing Damper

### Steps:

1. Drill a 3/16 in. hole in the duct, ideally 3 ft. downstream and 1 ft. upstream of any elbows or bends in the fresh air and stale air streams.
2. Insert the pitot tube with the tip facing into the air stream in the “Stale Air from Inside” stream. Move the pitot tube around in the duct (facing toward the airstream) and take an average reading. Record the reading.
3. Repeat Step 2 to measure the “Fresh Air to Inside” stream.
4. Review the readings and damper down the duct with the highest duct velocity pressure. Repeat Steps 2 and 3 until both ducts show identical readings. Upon completion of balancing, seal the holes with foil tape.

### Determining the CFM:

After balancing the airflows, calculate the CFM flow rate.

### Example:

This example shows how to determine the airflow for a 6 in diameter duct. If the duct velocity pressure reads 0.025 in w.g. on the digital manometer, use the chart that came with the pitot tube to determine a duct velocity of 640 ft/min. for a duct velocity pressure of 0.025 in w.g.

### CFM Calculation:

$$\begin{aligned}
 \text{CFM} &= \text{feet per minute} \times \text{cross section area of duct} \\
 &= 640 \times 0.196 \\
 &= 125
 \end{aligned}$$

**Table 23. Cross section area of some common duct sizes:**

Cross-Section Area (ft <sup>2</sup> )	Duct Size (in.)
0.087	4 duct
0.139	5 duct
0.196	6 duct
0.267	7 duct



## ATTENTION

Installations where the ERV is ducted directly to the return of a furnace may require additional dampening on the fresh air to building duct. This is due to the high return static pressures found in some furnace installations.

## Balancing The Airflows – Collar Port Method

Balancing ports are designed to be used in conjunction with a digital manometer to determine the stale and fresh airflows. Refer to “Collar Port Locations” to locate the ports for a particular model.

### Figure Callouts:

1. Measuring Device Digital Manometer
2. Protective Covers
3. Balancing Ports
4. 3/16” Tubing

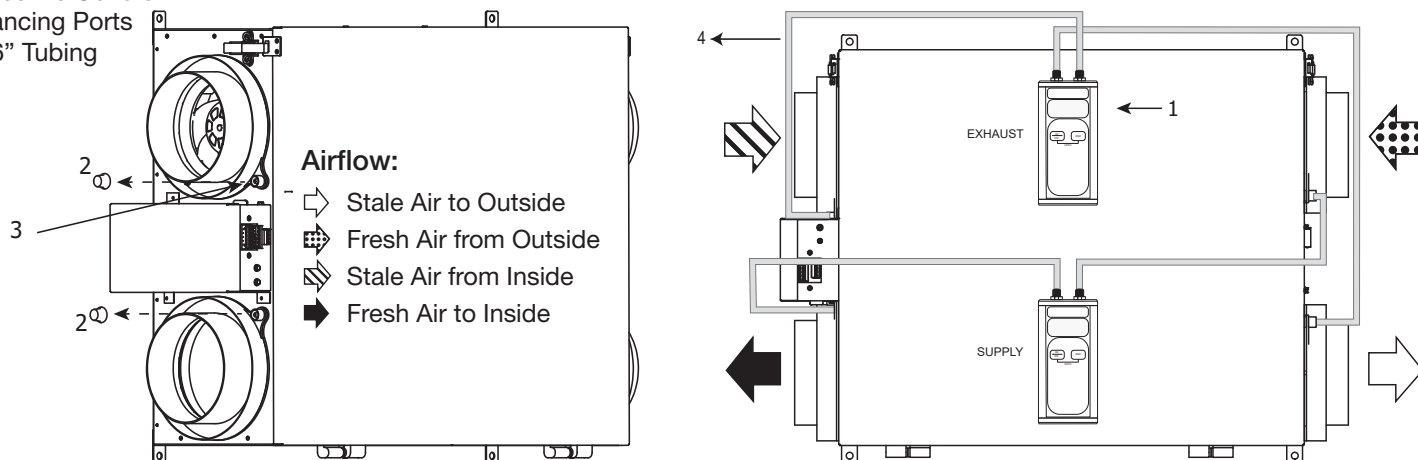

Figure 47. Balancing the Airflows - Collar Port Method

1. Prepare the pressure measuring device by connecting two hoses to the low and high pressure connections on the device. The illustrations show a digital manometer.
2. Ensure that the balancing ports located on the interior of the unit’s collars are plugged (open unit’s door to gain access to interior of unit’s collars).
3. Close door, initiate power and operate the HRV/ERV on high speed. Operate the forced air system on high speed if the HRV/ERV is connected to the forced air system.
4. Remove the protective covers on the exhaust stream balancing ports located on the exterior of the unit’s collars. Connect the two hoses from the measuring device to the two balancing ports on the exhaust stream collars. Record your reading. If you read a negative value, the two hoses need to be reversed. Re-plug collars.
5. Remove the protective covers on the supply stream balancing ports located on the exterior of the unit’s collars. Connect the two hoses from the measuring device to the two balancing ports on the supply stream collars. Record your reading. If you read a negative value, the two hoses need to be reversed. Re-plug collars.
6. Refer to the “Airflow Chart for Collar Port on METRO XTR” on page 39 and determine the supply and exhaust airflow rates.
7. Damper down the higher airflow and repeat steps 4 through 7 as required until both airflows are suitably balanced.
8. Remove pressure measuring device and reinstall the four protective covers on the exterior of unit’s collars.

## Collar Port Locations

### Door Ports:

1. Supply Balance Port Low (-)
2. Supply Balance Port High (+)
3. Exhaust Balance Port Low (-)
4. Exhaust Balance Port High (+)

### Airflow:

- ⇨ Stale Air to Outside
- ⇦ Fresh Air from Outside
- ⇩ Stale Air from Inside
- ⇨ Fresh Air to Inside

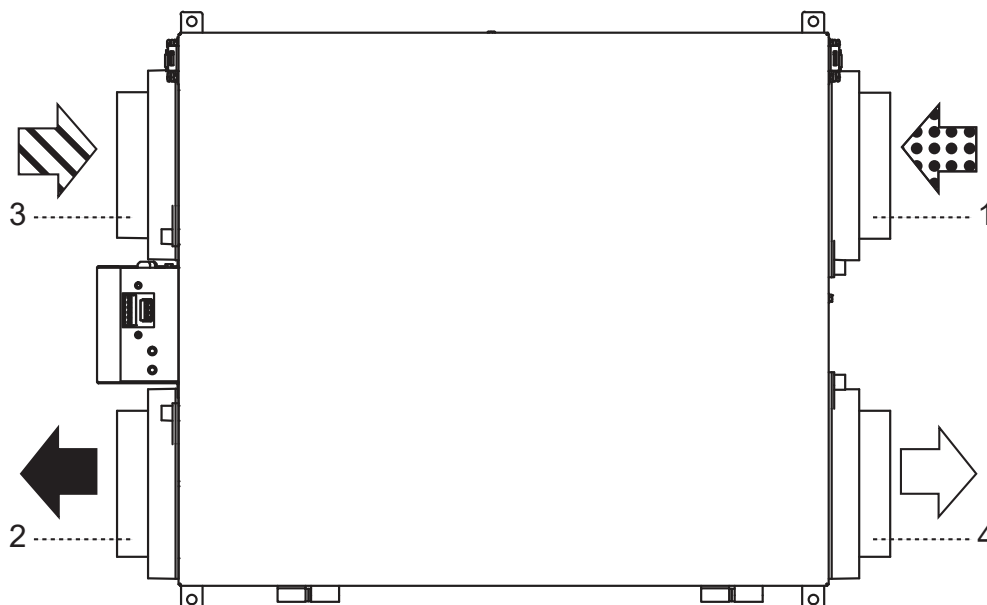

# Airflow Charts for Collar Port Balancing on METRO XTR

Hi 3				Hi 2				Hi 1			
Pressure Drop		Supply Airflow	Exhaust Airflow	Pressure Drop		Supply Airflow	Exhaust Airflow	Pressure Drop		Supply Airflow	Exhaust Airflow
("w.g.)	(Pa)	(cfm)	(cfm)	("w.g.)	(Pa)	(cfm)	(cfm)	("w.g.)	(Pa)	(cfm)	(cfm)
0.00	0	169	177	0.00	0	147	155	0.00	0	135	139
0.05	12	164	171	0.05	12	141	149	0.05	12	129	132
0.10	25	158	165	0.10	25	135	142	0.10	25	123	126
0.15	37	152	158	0.15	37	129	136	0.15	37	117	119
0.20	50	147	152	0.20	50	123	129	0.20	50	110	113
0.25	62	141	146	0.25	62	117	123	0.25	62	104	106
0.30	75	135	139	0.30	75	111	116	0.30	75	98	100
0.35	87	129	133	0.35	87	105	109	0.35	87	92	93
0.40	100	123	127	0.40	100	99	103	0.40	100	86	87
0.45	112	117	120	0.45	112	93	96	0.45	112	80	80
0.50	125	111	113	0.50	125	87	90	0.50	125	74	74
0.55	137	105	107	0.55	137	81	83	0.55	137	67	67
0.60	150	98	100	0.60	150	75	76	0.60	150	61	61
0.65	162	92	93	0.65	162	69	70	0.65	162	55	54
0.70	174	86	86	0.70	174	63	63	0.70	174	49	48
0.75	187	79	79	0.75	187	57	57	0.75	187	43	41
0.80	199	73	72	0.80	199	51	50	0.80	199	37	35
0.85	212	66	65	0.85	212	45	44	0.85	212	30	28
0.90	224	59	58	0.90	224	39	37	0.90	224	24	22
0.95	237	53	51	0.95	237	33	30	0.95	237	18	16
1.00	249	46	43	1.00	249	27	24	1.00	249	12	9
1.05	262	39	36	1.05	262	21	17	1.05	262	6	
1.10	274	32	29	1.10	274	15	11	1.10	274		
1.15	287	25	21	1.15	287	9	4	1.15	287		
1.20	299	18	14	1.20	299			1.20	299		
1.25	311	11	6	1.25	311			1.25	311		
1.30	324	4		1.30	324			1.30	324		

# Auto Balancing

Auto balancing enables the installer to dial in precise airflow to meet design and code requirements and the units will maintain the airflows through auto balancing after they are set.

Applicable units:

MAX XTR, MAX XTR PLUS, MAX XTR-FID, METRO 120ERV-ECM-AB, METRO 120ERV-ECM-FID, METRO 120F-ECM-AB, METRO 120F-ECM-FID

## Note:

- DXPL03 Control **MUST** be used for Auto Balancing
- Perform auto balancing with only the DXPL03 controller connected. Ensure timer is disconnected before initiating the process. Reconnect the timer once auto balancing is complete.

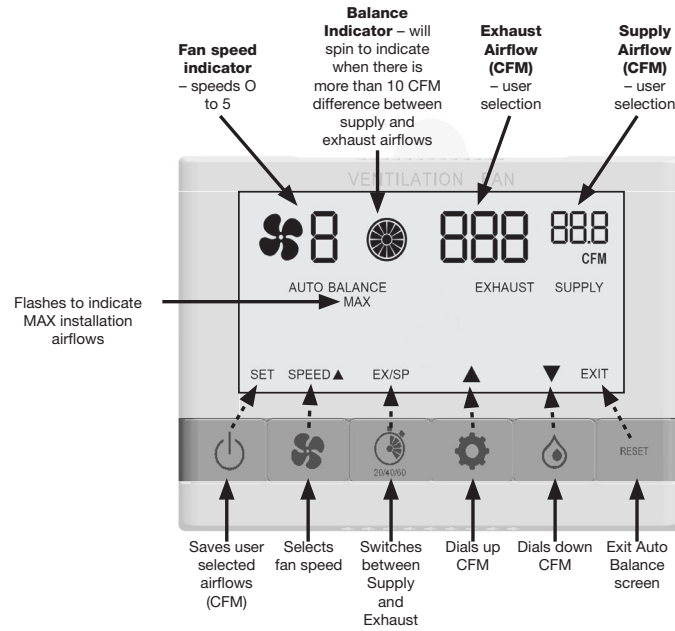

Figure 46. DXPL03 Deluxe Control Auto Balance Function

1. Power the HRV / ERV and allow Self test to complete. Self test takes approximately one minute in duration.
2. Press the power button to turn on the DXPL03 Deluxe Control.
3. Simultaneously press and hold the fan and gear buttons for 5 seconds until the screen changes and “Auto Balance” appears, then release the buttons.

*Do not attempt to operate the DXPL03 Deluxe Control once the buttons are released. For approximately 15 seconds the HRV / ERV will test for its installation maximum supply and exhaust airflows. The maximum airflows will be displayed for approximately 10 seconds. “MAX” will flash during this time. Speed 5 will then be displayed and “MAX” will no longer appear on the screen. The maximum supply and exhaust airflows values (CFM) are the maximum values (CFM) that units speeds 1 to 5 can be set to. Repeat this step if “Man Balance”\* is shown.*

4. Once speed 5 is displayed, select the airflow (supply or exhaust) to be adjusted by pressing the timer button . “SUPPLY” or “EXHAUST” will flash, indicating which airflow is selected for adjustment.
5. Press the gear button to increase the value (CFM) of the selected airflow until the target value (CFM) is reached. Press the water drop button to decrease the value (CFM) of the selected airflow until the target value (CFM) is reached. Once the target value (CFM) has been reached, the fans will adjust to meet the target value (CFM). Pause until the airflow values (CFM) have stabilized.

*Airflow values (CFM) increase and decrease in increments of 5 CFM. CFM fluctuations of +/- 10 CFM from target is acceptable. A Balance Indicator icon is located to the right of the fan speed. The Balance Indicator icon will spin to indicate when there is more than 10 CFM difference between supply and exhaust airflows.*

6. Once both the supply and exhaust airflows have stabilized to the target values, press the power button to save the settings. *No changes will be saved unless the power button is pressed before exiting the Auto Balance Screen. Saving the settings can be done at any time. Saving the settings after setting all 5 speeds is sufficient, however it is recommended to save after setting each speed, beginning with speed 5.*
7. Press the fan button to switch to the other 4 speeds and adjust using steps 4-6.

*When switching fan speeds, the HRV / ERV will take approximately 5 seconds to identify the default airflow values (CFM) before displaying it. Note: All speeds do not have to be adjusted. After speed 5 is adjusted, speeds 1 to 4 will adjust proportionally to the selected speed 5 value, for both airflows. These default values can be overridden if desired by setting speeds 1 to speed 4 following steps 4-6.*

8. To exit auto balance mode and return to the main screen press the RESET button. *After approximately 3 seconds the screen will change back to the main screen. The screen will display “Auto Balance”. If this is not shown, restart from step 3.*

*Over time, if the unit is unable to remain balanced “Auto Balance” will no longer appear on the main screen and the unit will run its five speeds at factory default. The unit will continuously adjust to maintain selected airflow values.*

## NOTE

Should any unexpected behaviour occur on the Auto Balance Screen or on the HRV/ERV, disconnect the HRV/ERV from the outlet, wait approximately 30 seconds and start from step 1.

\* Man Balance is used for diagnostic purposes only.

# Fault Indicator Display Board (FID)

## DESCRIPTION OF OPERATION:

A FID enabled HRV or ERV is capable of displaying error codes for certain types of faults which impact operation of the system. These errors are displayed on the screen during normal operation (i.e. not while on any installer/service screens). Active error codes are displayed for approximately 1 second on a 5 second interval.

An error will be displayed in place of the relative humidity (RH) numbers. For example, error 1 would appear as the letters "Err" in place of the RH reading and "1" would appear in place of the RH setting.

In the case of multiple active errors only the highest priority error (smallest error number) is displayed.



### List of Error codes

List of Error codes	
<b>Err 1</b>	Pressure Sensor Failure (either Supply or Exhaust)
<b>Err 2</b>	Temperature Sensor Failure
<b>Err 3</b>	Supply Airflow Too Low or Too High
<b>Err 4</b>	Exhaust Airflow Too Low or Too High
<b>Err 8</b>	Clean Filter (same as Wrench/Timer)
<b>Watts</b>	Displays Watts

## DESCRIPTION OF ERRORS:

Err 1: This error is activated if either the supply sensor or the exhaust sensor fails to respond or if the sensor is overloaded.

Err 2: This error is activated if the thermistor connection is broken.

Err 3: This error is activated if the HRV is unable to achieve the supply cfm air flow requested for the selected speed.  
The limit for cfm deviation from requested is:  $\pm(15\text{cfm} + 10\% \text{ of setting})$ .

Err 4: This error is activated if the HRV is unable to achieve the exhaust cfm air flow requested for the selected speed.  
The limit for cfm deviation from requested is:  $\pm(15\text{cfm} + 10\% \text{ of setting})$ .

Err 8: Filter change reminder activated.

### Notes:

- Err 5, 6, 7 are spare and not currently used.
- Err 1, 3 & 4 will only be activated in Auto Balancing Mode.
- To prevent false alarms Err 1, 3 & 4 have a time delay built-in. These also tie into the fail-retry logic when in Auto Balancing. For example, the sequence of events for a pressure sensor failure would be:
  - After selecting a speed or changing mode the system will disable speed/cfm alarms for 1-minute to allow the airflow to stabilize.
  - After 1 minute has passed the system will identify an issue with the sensor and start a 2-minute timer while it continues to attempt to communicate with the sensor.
  - After 2 minutes an alarm will be activated which is communicated to the DXPL03
  - The system will revert to Manual Mode for 3 minutes. During this time the alarm is still active.
  - After 3 minutes the alarms are cleared and the system attempts to restore Auto Balancing.
  - System goes back to step (a)

The result of this sequence is that the alarm will flash on the DXPL03 display for 3 minutes then get cleared for 3 minutes. This repeats until the issue is resolved or the system is switched to Man Balance.

## Power Monitor Description

Power monitor mode is activated on DXPL03 by pressing GEAR icon followed by POWER icon and holding both for 5 seconds on DXPL03 after unit has completed self-test.

Power is displayed in watts in place of the relative humidity (RH) numbers. Power monitor mode is cancelled by cycling power. This mode will time out in 5 minutes after it is first activated.

**Table 24. Troubleshooting**

Symptom	Cause	Solution
Poor airflow(s)	<ul style="list-style-type: none"> <li>• Mesh on outside hoods plugged</li> <li>• Filters plugged</li> <li>• Core obstructed</li> <li>• House grilles closed or blocked</li> <li>• Dampers closed (if installed)</li> <li>• Poor power supply at site</li> <li>• Ductwork is restricting HRV/ERV</li> <li>• Improper speed control setting</li> <li>• HRV/ERV airflow improperly balanced</li> </ul>	<ul style="list-style-type: none"> <li>• Clean exterior hoods or vents</li> <li>• Remove and clean both filter and core</li> <li>• If unit is equipped with MERV 13 filters, replace every 3 months</li> <li>• Check and open grilles</li> <li>• Open and adjust dampers</li> <li>• Have electrician check supply voltage at house</li> <li>• Check duct installation</li> <li>• Increase the speed of the HRV/ERV</li> <li>• Have contractor balance the HRV/ERV</li> </ul>
Supply air feels cold	<ul style="list-style-type: none"> <li>• Poor location of supply grilles</li> <li>• Airflow may irritate occupants</li> <li>• Outdoor temperature extremely cold</li> </ul>	<ul style="list-style-type: none"> <li>• Locate the grilles high on the walls or under the baseboards</li> <li>• Install ceiling mounted diffuser or grilles so as not to direct airflow onto occupants (e.g. over a couch)</li> <li>• Turn down the HRV/ERV supply speed</li> <li>• A small duct heater (1kw) could be used to temper the supply air</li> <li>• Placement of furniture or closed doors restricting movement of air in home; consider rearranging</li> <li>• If supply air is ducted into furnace return, the furnace fan may need to run continuously to distribute ventilation air comfortably</li> </ul>
Dehumidistat is not operating	<ul style="list-style-type: none"> <li>• Outdoor temperature is above 59°F (15°C)</li> <li>• Improper low-voltage connection</li> <li>• External low voltage is shorted out by a staple or nail</li> <li>• Check dehumidistat setting; it may be OFF</li> </ul>	<ul style="list-style-type: none"> <li>• Dehumidistat is functioning normally (see “Dehumidistat Disable” on page 13)</li> <li>• Check that the correct terminals have been used</li> <li>• Check external wiring for a short</li> <li>• Set the dehumidistat at the desired level</li> </ul>
Humidity levels are too high; condensation is appearing on windows	<ul style="list-style-type: none"> <li>• Dehumidistat set too high</li> <li>• HRV/ERV unit is undersized to handle a hot tub, indoor pool, etc. (Occupant Lifestyle)</li> <li>• Moisture coming into the home from a non-vented or non-heated crawl space</li> <li>• Moisture remaining in washroom and/or kitchen areas</li> <li>• Condensation seems to form in the spring and fall seasons</li> <li>• HRV/ERV is set at too low a speed</li> </ul>	<ul style="list-style-type: none"> <li>• Set dehumidistat at lower level</li> <li>• Cover pool or hot tub when not in use</li> <li>• Avoid hanging clothes to dry indoors, storing wood indoors, and venting dryer inside</li> <li>• Vent crawl space and place a vapor barrier on the floor of the crawl space</li> <li>• Ducts from washroom should be sized to remove moist air as effectively as possible; use of a bathroom fan for short periods will remove additional moisture</li> <li>• On humid days, as seasons change, some condensation may appear but the home’s air quality will remain high with some HRV/ERV use</li> <li>• Increase speed of HRV/ERV</li> </ul>
Humidity levels are too low	<ul style="list-style-type: none"> <li>• Dehumidistat control set too low</li> <li>• Blower speed of HRV/ERV is too high</li> <li>• Occupant lifestyle issue</li> <li>• HRV/ERV airflows may be improperly balanced</li> </ul>	<ul style="list-style-type: none"> <li>• Set dehumidistat at higher level</li> <li>• Decrease HRV/ERV blower speed</li> <li>• Humidity may have to be added through use of humidifiers</li> <li>• Have a contractor balance HRV/ERV airflows</li> </ul>
HRV/ERV units and/or ducts frosting up	<ul style="list-style-type: none"> <li>• HRV/ERV air flows are improperly balanced</li> <li>• Malfunction of the HRV/ERV defrost system</li> </ul>	<ul style="list-style-type: none"> <li>• NOTE: Minimal frost build-up is expected on cores before unit initiates defrost cycle</li> <li>• Have HVAC contractor balance the HRV/ERV airflows</li> <li>• Ensure damper defrost is operating during self-test</li> </ul>
Condensation or ice build-up in insulated duct to the outside	<ul style="list-style-type: none"> <li>• Incomplete vapor barrier around insulated duct</li> <li>• Hole or tear in outer duct covering</li> </ul>	<ul style="list-style-type: none"> <li>• Tape and seal all joints</li> <li>• Tape any holes or tears made in the outer duct covering</li> <li>• Ensure that the vapor barrier is completely sealed</li> </ul>
Water in the bottom of the HRV/ERV unit	<ul style="list-style-type: none"> <li>• Drain pans plugged</li> <li>• Improper connection of HRV/ERV drain lines</li> <li>• HRV/ERV is not level</li> <li>• Drain lines obstructed</li> <li>• HRV/ERV heat exchange core is not properly installed</li> </ul>	<ul style="list-style-type: none"> <li>• Look for kinks in the drain line</li> <li>• Check water drain connections</li> <li>• Make sure water drains properly from pan(s)</li> </ul>
Incorrect temperature reading / unit not defrosting properly / erratic airflow control.	<ul style="list-style-type: none"> <li>• Thermistor switch wired in the incorrect position</li> <li>• Thermistor switched to the wrong side</li> </ul>	<ul style="list-style-type: none"> <li>• Verify the thermistor switch is installed and wired to the correct terminal</li> <li>• Confirm the switch position corresponds with correct thermistor for sensing</li> <li>• This unit uses a manual switch, ensure it is set to the active thermistor side</li> <li>• Swap switch position as provided in manual</li> </ul>

### **WARNING**



Electric Shock Hazard.

Can cause injury or death.

Disconnect all remote electrical power supplies before servicing.

Unit may have multiple power supplies. Unit must be connected to a grounded power supply in accordance with national and local codes.

1. Inspect exterior hoods and vents at least once a month and make sure stale and fresh air supply hoods are not blocked or restricted by leaves, grass, or snow. In winter, it is especially important to make sure snow is not blocking the hoods or that frost has not built up on the wire mesh (bird screen).

### **IMPORTANT**

Blockage of hoods or vents may cause an airflow imbalance.

2. Clean or replace air filters 4 times a year. Clean factory provided MERV 6 polyester filter and replace MERV 13 paper framed filter, MERV 8 for MAX XTR PLUS:
  - a. Disconnect power to the unit.
  - b. Open access door.
  - c. Slide the core out slightly.
  - d. Remove filter clips if present.
  - e. Remove filters off the core.
  - f. Rinse filters with water or a combination of mild soap and water. Do not clean in the dishwasher.
  - g. To reassemble, place clean filter(s) – wet or dry – back into their positions against the core and return clips to their original position.
  - h. Slide core back into its original position.
3. Clean core and inside of cabinet 2 times a year
  - a. Disconnect power to the unit.
  - b. Open access door.
  - c. Carefully grip ends of core and pull evenly outward. Core may be snug, but will slide out of the channel.
  - d. Remove filters as above.
  - e. ERV Core - vacuum ONLY to clean core, do not get wet.
  - f. Install clean filters.
  - g. Wipe down the inside of the cabinet with a damp cloth to remove dirt, bugs, and any debris.

### **IMPORTANT**

Vacuum ONLY to clean ERV core.

4. Install clean core as follows:
  - a. Install the bottom flange of the core guide into the bottom H channel approximately 1/4" (6 mm).
  - b. Install the left or right side flange of the core guide approximately 1/4" (6 mm) followed by the other side flange.
  - c. Install the top flange of the core guide into the top H channel approximately 1/4" (6 mm).
  - d. With all four corners in place and the core straight and even, push hard in the center of the core until the core stops on the back of the cabinet.

NOTE: Core will appear to stick out from cabinet approximately 1/8" (3 mm). This is designed this way so that the access door will fit tight against the core.
5. Clean drain (condensate) line 2 times a year. Inspect drain line, drain spout, and P-trap for blockage, mold, or kinks in the line. Flush with warm soapy water and replace line if worn, bent, or cannot be cleaned.
6. Clean duct system if required. The duct system may accumulate dirt. Wipe and vacuum the inside of the duct once every year. (A capable HVAC service company will best perform this procedure.)

7. Motors are maintenance free, however, impeller blades must be cleaned.

NOTE: Impellers may accumulate dirt causing an imbalance and/or excessive vibration of the HRV/ERV unit. A reduction in the airflow may also occur. In new construction, this may result within the first year due to heavy dust.

- a. Disconnect power to the unit.
- b. Open access door.
- c. Remove the core.
- d. Remove ducting (metal and/or flexible insulated type) from the ports which are connected immediately in-line with the fan assembly.
- e. Use a small brush and scrub individual fan blades until clean. Avoid moving or damaging balancing flat weight (clip is usually found on one or more of the fan blades).
- f. Vacuum and wipe out.
- g. Reassemble. Be sure ducting is attached firmly. Seal and tape insulation and moisture barrier.

A capable HVAC service company will best perform this procedure.