

1500E-ECM

HEAT RECOVERY VENTILATOR



ENGINEERING DATA:

AIRFLOW

1500 CFM (705 L/s) at 1.0 in. w.g. ESP.

PERFORMANCE

65% effective at 1500 CFM (705 L/s).

CORES

Six patented aluminum heat recovery cores arranged for efficient cross-flow ventilation.

BLOWERS

Two direct-drive centrifugal blowers, one per air stream.

FILTERS

Two 20 in. x 16 in. x 2 in. (508 mm x 406 mm x 50 mm) pleated filters in each air stream. MERV 8 efficiency.

CONNECTION DUCT SIZES

Two 19 in. x 16 in. (482 mm x 406 mm) to and from building under cabinet. Two 18 in. x

17 in. (457 mm x 431 mm) hoods included on side of cabinet with washable screens.

CABINET

20 gauge powder coated steel 1 in. (25 mm) thick Elastomeric insulation.

DRAIN

Two powder coated galvanized steel drain pans with 1/2 in. (12 mm) O.D. drain connections.

MOUNTING

Rooftop mounted on optional curb (Part No. 53-1500)

ELECTRONICS

Integrated microprocessor board. Three independently adjustable motor speeds.

DEFROST

Factory set defrost time. Supply motor is shut off while exhaust air defrosts core.

VOLTAGE OPTIONS:

| VOLTAGE | PHASE | MOTOR | AMPS | MCA | MOP | SKU |
|---------|-------|---|------|------|-----|----------------------|
| 208 | 1 | Two ECM, 1.0 hp, single shaft, variable speed | 20.6 | 25.8 | 30 | 200-1500E-ECM-240SP* |
| 240 | 1 | | 18.2 | 20.5 | 30 | |

* Dual voltage unit

CONTROLS

99-BC02 - Lifebreath Ventilation Control

2 speed fan setting (Low/High). Humidity control through adjustable Dehumidistat. Compatible with 99-DET02 Wireless Timers. 3 wire connection: 20 gauge wire (minimum).

99-500 - 3 Speed Control

3 speed fan setting (Low/Medium/High). 4 wire connection: 20 gauge wire (minimum).

TIMER OPTIONS

99-DET01 - Lifebreath 20/40/60 Minute Timer

Initiates high speed ventilation for 20, 40 or 60 minutes. 3 wire connection.

99-DET02 - Wireless Lifebreath 20/40/60 Minute Timer

Initiates high speed ventilation for 20, 40 or 60 minutes. Wirelessly connects to main control for ease of installation. 40' approximate range. **Exclusive to Lifebreath.**

99-RX02 - Wireless Lifebreath Repeater

Extends range of 99-DET02 Wireless Timers. Plugs into 120V power outlet. Wirelessly connects to main control and 99-DET02. Install at halfway point between timer and main wall control if timer is out of range.

1500E-ECM

HEAT RECOVERY VENTILATOR



Airflow Performance

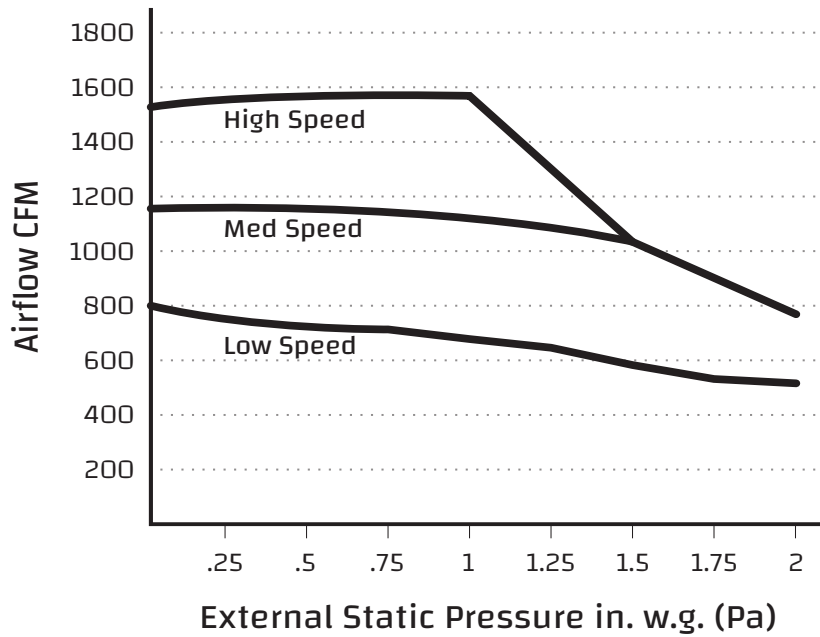

**ISO
9001
REGISTERED**

WEIGHT:
530 LBS (240 KG)

SHIPPING WEIGHT:
650 LBS (290 KG)

NOTE:
Service clearance is 30 in. All specifications are subject to change without notice.

DIMENSIONS

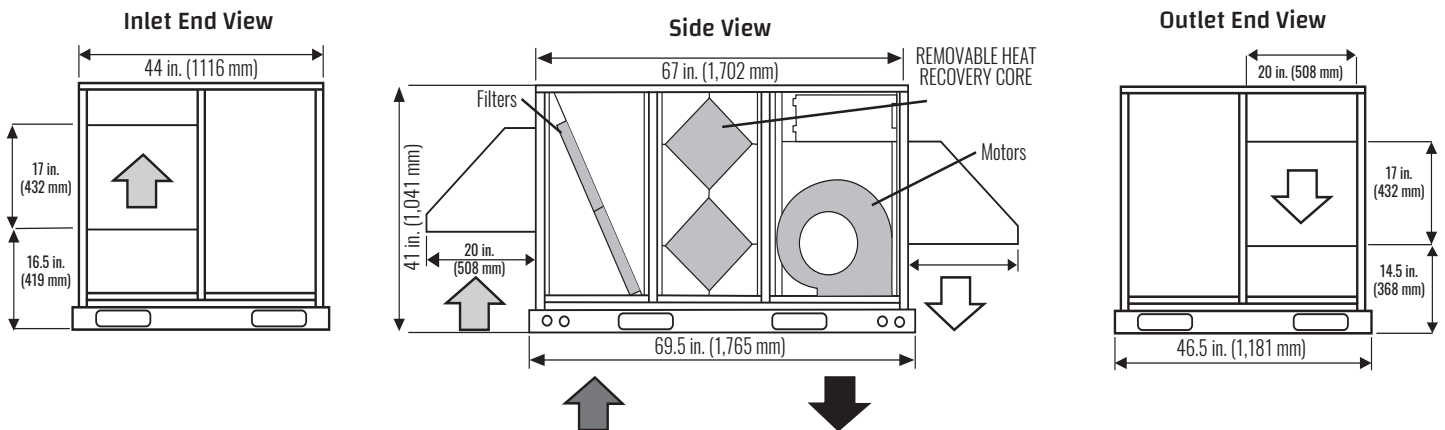

Airflow:

- ☐ Stale Air to Outside
- ☐ Fresh Air from Outside
- ☐ Stale Air from Inside
- ☐ Fresh Air to Inside

Date: _____ Contractor: _____

Tag: _____ Supplier: _____

Project: _____ Qty: _____ Quote #: _____

Engineer: _____ Submitted By: _____

Control: _____ Timer: _____ Timer Qty: _____

WARRANTY

Units carry a 15 year warranty on the HRV core and a 2 year replacement parts warranty.

All units conform to CSA and UL standards



www.lifebreath.com