

170 ERVD
172 CFM @ 0.3 (75) IN. W.G. (PA)

SUPERIOR PERFORMANCE TOP CHOICE ERV

- -25C HVI Cold Weather Certified ERV
- Three units in one by the way of the high-speed select feature allows for maximum control of airflow and comfort
- Enthalpy energy exchange core
- Top port design with built-in balancing dampers
- No drains required
- Door Port Balancing & Adjustable Dampers
- Energy Star: This product earned the ENERGY STAR® by meeting strict energy efficiency guidelines set by Natural Resources Canada and the US EPA. It meets ENERGY STAR® requirements only when used in Canada.

NOTE: Front clearance of 25 in. (635 mm) is recommended for servicing unit.
All ducts use 6 in. (152 mm) oval collars.
Balancing dampers are located on all collars.
All units conform to CSA and UL standards.

DIMENSIONS

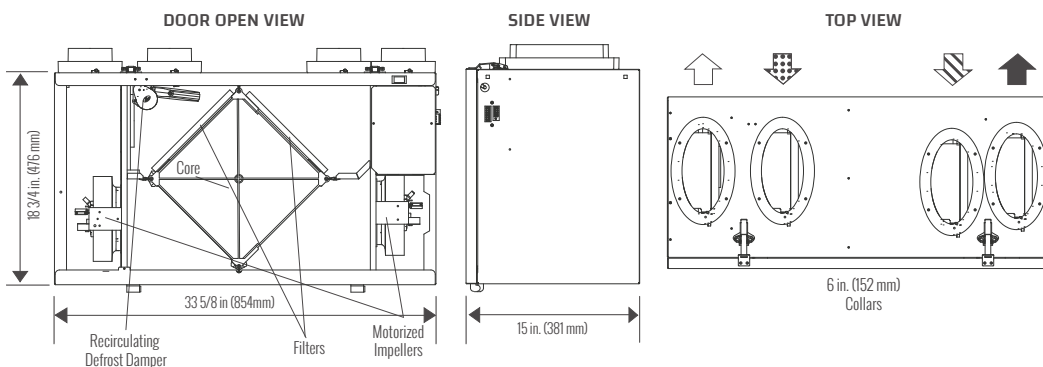

FEATURES

TOTAL RECOVERY CORE

Cross-flow energy recover core transfers heat and water vapor between two airstreams. Easily removed for cleaning or service.

MOTORS AND BLOWERS

Each airstream has an independent motorized impeller with multiple fan speed operation.

MERV 6 FILTERS

Washable air filters in exhaust and supply airstreams.
MERV 13 Upgrade: 65-195-6R.

MOUNTING

Adjustable hanging straps supplied.

DEFROST

Recirculating damper defrost system.

CASE

22 gauge prepainted galvanized steel for superior corrosion resistance, insulated to prevent exterior condensation.

INSTALLER SELECTABLE HIGH SPEED SETTINGS

Adjustable DIP switches are located on the circuit board, Hi3 is the factory setting. Refer to the installation manual for adjustment instructions.

ELECTRONICS

The main control can be wall mounted in a central location of the home. 3 wire 20 gauge (min.) 100 ft length (max.).

Weight: 57 lbs (25.8 KG) • Shipping Weight: 67 lbs (30 KG)

LIFEBREATH[®] 170 ERVD

Indoor Air Systems ENERGY RECOVERY VENTILATOR

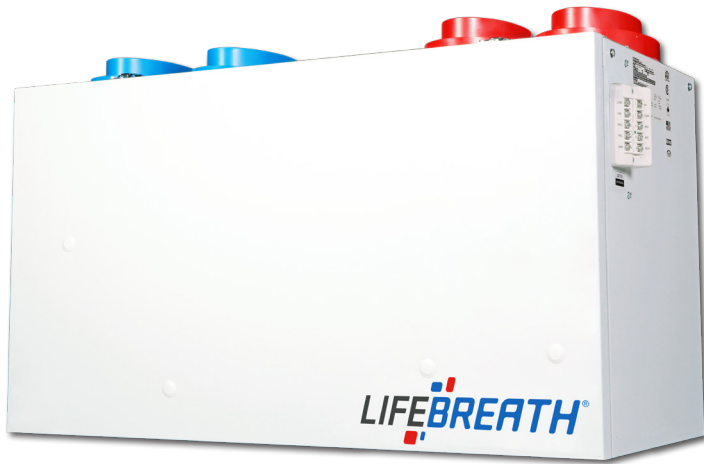

SPECIFICATIONS

MODEL:	170 ERVD
VOLTAGE:	120 V
FREQUENCY:	60 Hz
WATTS @ 49 CFM (23 L/S):	60 W
CURRENT:	1.4 A
AIRFLOW @ 0.3:	172 CFM
WEIGHT:	51 lbs / 23 kg
DRAIN:	Optional
MCA:	2.0 A
MOP:	15 A
WARRANTY:	Units carry a 5 year warranty on the ERV core and a 5 year replacement parts warranty.



PERFORMANCE

IN. W.G. (PA)	0.2 (50) CFM (L/s)	0.3 (75) CFM (L/s)	0.4 (100) CFM (L/s)	0.5 (125) CFM (L/s)	0.6 (150) CFM (L/s)	0.7 (175) CFM (L/s)	0.8 (200) CFM (L/s)	0.9 (225) CFM (L/s)
Net Supply Airflow	182 (86)	172 (81)	161 (76)	150 (71)	140 (66)	127 (60)	117 (55)	104 (49)
Gross Supply Airflow	191 (90)	180 (85)	167 (79)	157 (74)	146 (69)	133 (63)	121 (57)	108 (51)
Gross Exhaust Airflow	180 (85)	170 (80)	159 (75)	148 (70)	138 (65)	125 (59)	114 (54)	104 (49)

Sensible Effectiveness (ASE)
@ 66 CFM (31 L/s) 32°F (0°C) 89%

Sensible Efficiency (SRE)
@ 49 CFM (23 L/s) 32°F (0°C) 77%

Sensible Efficiency (SRE)
@ 66 CFM (31 L/s) 32°F (0°C) 75%

Total Efficiency (TRE)
@ 64 CFM (30 L/s) 95°F (35°C) 51%

Sensible Efficiency (SRE)
@ 68 CFM (32 L/s) -13°F (-25°C) 62%

