

LIFEBREATH[®] 205 MAX

Indoor Air Systems **HEAT RECOVERY VENTILATOR**



205 MAX
182 CFM @ 0.3 (75) IN. W.G. (PA)

TOP PORT DESIGN FOR FLEXIBLE INSTALLATIONS, WITH DOOR PORT BALANCING, & FEATURING A HIGH EFFICIENCY HEX CORE

- High Efficiency Hex Core
- Door Port Balancing & Adjustable Dampers
- Top Ported
- DXPL03 Digital Wall Control included, for easy programmability
- Outstanding Cold Weather Performance

NOTE: Front clearance of 25 in. (635 mm) is recommended for servicing unit.
All ducts use 5 in. (125 mm) round collars.
All units conform to CSA and UL standards.

DIMENSIONS

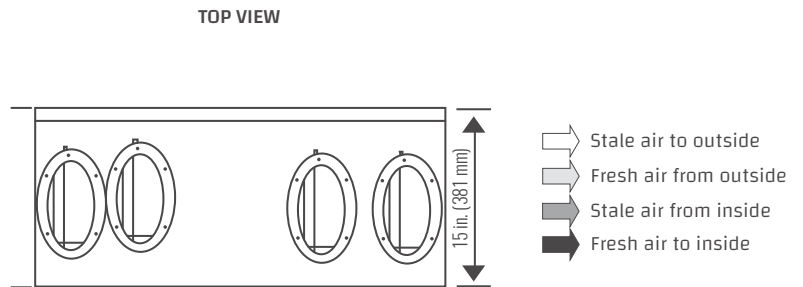
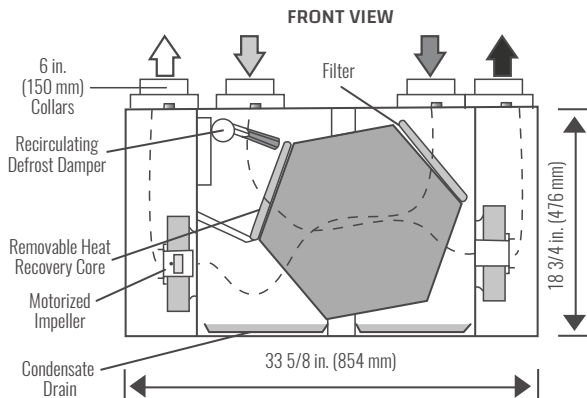

FEATURES

THERMALLY CONDUCTIVE HEX CORE

Counter-flow heat recovery core transfers heat between two airstreams. It is easily removed for cleaning or service.

MOTORS AND BLOWERS

Each airstream has one centrifugal blower driven by a common PSC motor, with multiple fan speed operations.

MERV 6 FILTERS

Washable air filters in exhaust and supply airstreams.
MERV 13 Upgrade: 65-195-6R.

MOUNTING

Four threaded inserts at corners of the cabinet designed to accept the "S" hooks and hanging straps supplied with the unit

DEFROST

Intelligent recirculating damper defrost system.

CASE

22 gauge prepainted galvanized steel for superior corrosion resistance, insulated to prevent exterior condensation. Drain connections 2 - 1/2 in. (12 mm) OD. Balancing ports are located on door.

INSTALLER SELECTABLE HIGH SPEED SETTINGS

Adjustable DIP switches are located on the circuit board, Hi3 is the factory setting. Refer to the installation manual for adjustment instructions.

ELECTRONICS

The optional control can be wall mounted in a central location of the home. 3 wire 20 gauge (min.) 100 ft length (max.).

LIFEBREATH[®] 205 MAX

Indoor Air Systems **HEAT RECOVERY VENTILATOR**



SPECIFICATIONS

MODEL:	205 MAX
VOLTAGE:	120 V
FREQUENCY:	60 Hz
WATTS @ 64 CFM (30 L/S):	61 W
CURRENT:	1.4 A
AIRFLOW @ 0.3:	182 CFM
WEIGHT:	57 lbs / 25.8 kg
DRAIN:	Yes
MCA:	2.0 A
MOP:	15 A
WARRANTY:	Units carry a lifetime warranty on the HRV core and a 5 year replacement parts warranty.



PERFORMANCE

IN. W.G. (PA)	0.1 (25) CFM (L/s)	0.2 (50) CFM (L/s)	0.3 (75) CFM (L/s)	0.4 (100) CFM (L/s)	0.5 (125) CFM (L/s)	0.6 (150) CFM (L/s)	0.7 (175) CFM (L/s)	0.8 (200) CFM (L/s)	0.9 (225) CFM (L/s)
Net Supply Airflow	203 (96)	193 (91)	182 (86)	170 (80)	159 (75)	146 (69)	133 (63)	121 (57)	106 (50)
Gross Supply Airflow	206 (97)	195 (92)	184 (87)	174 (82)	161 (76)	148 (70)	136 (64)	123 (58)	108 (51)
Gross Exhaust Airflow	212 (100)	197 (93)	184 (87)	172 (81)	157 (74)	144 (68)	129 (61)	114 (54)	102 (48)

**Sensible Efficiency (ASE)
@ 64 CFM (30 L/s)** 32°F (0°C) 85%

**Sensible Efficiency (SRE)
@ 64 CFM (30 L/s)** 32°F (0°C) 76%

**Sensible Efficiency (SRE)
@ 102 CFM (48 L/s)** -13°F (-25°C) 70%

