



RNC6-ES  
163 CFM @ 0.3 (75) IN. W.G. (PA)

**5" DUCT CONNECTIONS, TOP PORT DESIGN, DOOR PORT BALANCING, AND 3 SELECT HIGH-SPEED SETTINGS**

- Cross Flow Core
- Door Port Balancing & Adjustable Dampers
- Top Ported
- Excellent Low Temperature Performance
- Energy Star: This product earned the ENERGY STAR® by meeting strict energy efficiency guidelines set by Natural Resources Canada and the US EPA. It meets ENERGY STAR® requirements only when used in Canada

NOTE: Front clearance of 25 in. (635 mm) is recommended for servicing unit.  
Round duct connections are 5 in. (127 mm).  
Oval collars use 6 in. (152 mm) connections.  
All units conform to CSA and UL standards.

**DIMENSIONS**

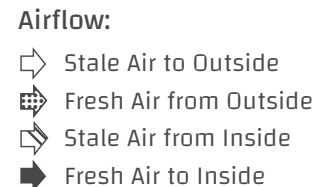
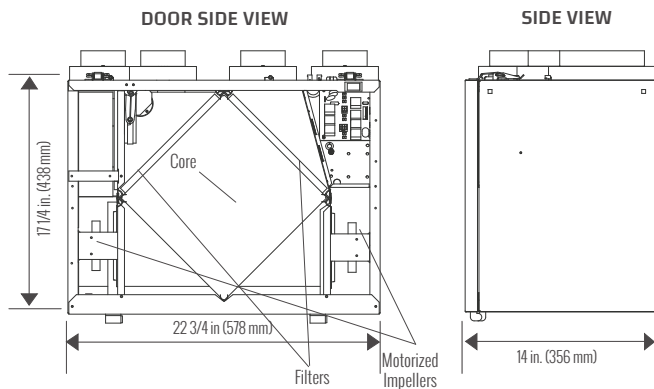

**FEATURES**

**THERMALLY CONDUCTIVE SQUARE CORE**

Polymer/aluminum cross-flow heat recovery core transfers heat between the two airstreams. It is easily removed for cleaning or service.

**MOTORS AND BLOWERS**

Each airstream has one motorized impeller with multiple fan speed operations.

**MERV 6 FILTERS**

Washable air filters in exhaust and supply airstreams.  
MERV 13 Upgrade: 65-195-6R.

**MOUNTING**

Four threaded inserts at corners of the cabinet designed to accept the "S" hooks and hanging straps supplied with the unit.

**DEFROST**

Intelligent recirculating damper defrost system.

**CASE**

22 gauge prepainted galvanized steel for superior corrosion resistance. Insulated to prevent exterior condensation. Drain connections 2 - 1/2 in. (12 mm) OD. Balancing ports are located on door.

**INSTALLER SELECTABLE HIGH SPEED SETTINGS**

Adjustable DIP switches are located on the circuit board, Hi3 is the factory setting. Refer to the installation manual for adjustment instructions.

**ELECTRONICS**

The optional control can be wall mounted in a central location of the home. 3 wire 20 gauge (min.) 100 ft length (max.).

Weight: 51 lbs (23 KG) • Shipping Weight: 54 lbs (25 KG)



**SPECIFICATIONS**

<b>MODEL:</b>	<b>RNC6-ES</b>
<b>VOLTAGE:</b>	120 V
<b>FREQUENCY:</b>	60 Hz
<b>WATTS @ 64 CFM (30 L/S):</b>	47 W
<b>CURRENT:</b>	1.25 A
<b>AIRFLOW @ 0.3:</b>	163 CFM
<b>WEIGHT:</b>	51 lbs / 25.8 kg
<b>DRAIN:</b>	Yes
<b>MCA:</b>	2.0 A
<b>MOP:</b>	15 A
<b>WARRANTY:</b>	Units carry a lifetime warranty on the HRV core and a 5 year replacement parts warranty.



**PERFORMANCE**

IN. W.G. (PA)	0.1 (25) CFM (L/s)	0.2 (50) CFM (L/s)	0.3 (75) CFM (L/s)	0.4 (100) CFM (L/s)	0.5 (125) CFM (L/s)	0.6 (150) CFM (L/s)	0.7 (175) CFM (L/s)	0.8 (200) CFM (L/s)	0.9 (225) CFM (L/s)
<b>Net Supply Airflow</b>	186 (88)	174 (82)	163 (77)	150 (71)	140 (66)	127 (60)	114 (54)	102 (48)	89 (42)
<b>Gross Supply Airflow</b>	191 (90)	178 (84)	167 (79)	155 (73)	142 (67)	129 (61)	117 (55)	104 (49)	89 (42)
<b>Gross Exhaust Airflow</b>	182 (86)	170 (80)	159 (75)	146 (69)	136 (64)	123 (58)	110 (52)	97 (46)	83 (39)

<b>Sensible Effectiveness (ASE) @ 64 CFM (30 L/s)</b>	32°F (0°C)	75%
<b>Sensible Efficiency (SRE) @ 64 CFM (30 L/s)</b>	32°F (0°C)	65%
<b>Sensible Efficiency (SRE) @ 70 CFM (33 L/s)</b>	-13°F (-25°C)	60%

