



## HEAT RECOVERY VENTILATORS

# HRV

**155 MAX 2019**  
**205 MAX**  
**267 MAX**  
**195 DCS**

**RNC6 ES**  
**RNC6 HEX TPD**  
**RNC5 HEX TPF**  
**RNC5 TPD**  
**RNC5 TPF**  
**RNC4 TPD**

**RNC 155 2019**  
**RNC 200**  
**RNC 205**  
**RNC 205 PLUS**  
**RNC 88**

**Installation Manual**

## Pre-Installation Notes



### Note

- Due to ongoing research and product development, specifications, ratings, and dimensions are subject to change without notice. Refer to [www.lifebreath.com](http://www.lifebreath.com) for the latest product information.



### Attention

- Do not apply electrical power to the unit until after the completion of the installation (including installation of low voltage control wiring).
- Ensure the installation and wiring is in accordance with all local electrical codes.
- Plug the unit into a standard designated (120 VAC) electrical outlet with ground.
- The use of an extension cord with this unit is not recommended. If the installation requires further wiring, have a licensed electrician make all the electrical connections. The recommended circuit is a separate 15 A/120 V circuit.



### Caution

- Before installation, careful consideration must be given to how this system will operate if connected to any other piece of mechanical equipment, i.e., a forced air furnace or air handler, operating at a higher static. After installation, the compatibility of the two pieces of equipment must be confirmed, by measuring the airflows of the HRV, by using the balancing procedure found in this manual. Never install a ventilator in a situation where its normal operation, lack of operation or partial failure may result in the back drafting or improper functioning of vented combustion equipment
- Unit must be installed level to ensure proper condensate drainage. Due to the broad range of installation and operational conditions, consider the possibility of condensation forming on either the unit or connecting ducting. Objects below the installation may be exposed to condensate.
- Do not install control wiring alongside electrical wire.



### Warning

- Disconnect the power from the unit before cleaning or servicing.
- To prevent electrical shock, it is extremely important to confirm the polarity of the power line that is switched by the safety (disconnect) switch. The hot line (black) is the proper line for switching. Use either a voltmeter or test lamp to confirm the absence of a voltage between the disconnect switch and ground (on the cabinet) while the door is open. This procedure must be followed, as dwellings are occasionally wired improperly. Always ensure the proper grounding of the unit.
- Improper installation, adjustment, alteration, service, or maintenance can cause property damage, personal injury or loss of life. Installation and service must be performed by a qualified installer or service agency.

# Table of Contents

1	Location Notes .....	4	21	Installer Selectable High Speed Settings .....	24
2	Serial Number Nomenclature Breakdown.....	4	22	Dimensional Drawings.....	25
3	Simplified Installation (Return/Return Method) ....	5	23	Balancing the Airflows.....	28
4	Partially Dedicated System Installation .....	6	24	Balancing the Airflows – Pitot Tube .....	30
5	Fully Dedicated System Installation.....	7	25	Balancing the Airflows – Door Ports.....	31
6	Default & Optional Duct Configurations (195DCS) .	8	26	Door Port Locations.....	32
7	Mounting (RNC4-TPD, RNC4-TPF, & RNC 88) .....	9	27	Airflow Charts (RNC88).....	33
8	Hanging Straps .....	10	28	Airflow Charts (RNC4-TPD) .....	34
9	Drain Connection .....	11	29	Airflow Charts (RNC6-ES).....	36
10	Grilles .....	12	30	Airflow Charts (RNC5-TPD/TPF).....	38
11	Grille Fittings.....	13	31	Airflow Charts (RNC6-HEX-TPD/5-HEX-TPF) .....	40
12	Lifebreath Weather Hoods .....	14	32	Airflow Charts (RNC155 2019).....	42
13	Lifebreath Dual Hood.....	15	33	Airflow Charts (RNC200).....	45
14	Terminal Blocks .....	16	34	Airflow Charts (RNC205).....	46
15	Main Control Installation (99-DXPL03) .....	17	35	Airflow Charts (RNC205 PLUS).....	48
16	Main Control Installation (99-BC02/3/4) .....	18	36	Airflow Charts (155 MAX 2019).....	51
17	Interlocking the HRV .....	19	37	Airflow Charts (205MAX).....	52
18	Additional Controls .....	20	38	Airflow Charts (267MAX).....	54
19	Timers .....	21	39	Troubleshooting .....	56
20	Repeater .....	23			

## Homeowners Warranty Information

After the installation is complete, fill out the Warranty Information page in the Homeowner’s manual.



# 1 LOCATION NOTES

---

Install the unit in a heated space that provides clearance for service access. A typical location is in either a mechanical room or an area close to the outside wall within proximity to where the weather hoods are mounted. If a basement area is inconvenient or non-existent, install the unit in a utility room or laundry room.

Leave enough clearance at the front of the access door for servicing the air filters and core. The recommended clearance is a minimum of 25 in. (635 mm) for opening and closing the door. Four straps are provided with the unit for hanging it from the basement floor joists.

Attic installations are not recommended due to:

- The complexity of work to install
- Difficulty of access for servicing and cleaning
- Freezing conditions in the attic

If attic installation is necessary, the unit must be situated in a conditioned space.

# 2 SERIAL NUMBER NOMENCLATURE BREAKDOWN

---

Each Serial Number begins with a 2-character alpha code followed by an 11-digit number code.

Example Serial number:

**XA 08082312345**

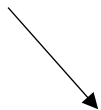

The first 6 digits represent the manufactured date following MMDDYY.

The second character represents model features.

A= Auto Balance (AB)

F = Fault Indicator Display (FID)

Therefore, this model would be a unit with Auto Balance features manufactured on Aug 8th, 2023.

## Note: ENERGY STAR®

### If the unit is certified ENERGY STAR®, the following applies:

- This product earned the ENERGY STAR® by meeting strict energy efficiency guidelines set by Natural Resources Canada and the US EPA. This product meets ENERGY STAR® requirements only when used in Canada.
- To ensure quiet operation of the ENERGY STAR® certified H/ERV, each product model must be installed using sound attenuation techniques appropriate for the installation.
- The way your heat/energy-recovery ventilator is installed can make a significant difference to the electrical energy you use. To minimize the electricity use of the heat/energy-recovery ventilator, a stand-alone fully ducted installation is recommended. If you choose a simplified installation that operates your furnace air handler for room-to-room ventilation, an electrically efficient furnace that has an electronically commutated (EC) variable speed blower motor will minimize your electrical energy consumption and operating cost.
- Installation of a user-accessible control with your product model will improve comfort and may significantly reduce the product model's energy use.

### 3 SIMPLIFIED INSTALLATION (RETURN/RETURN METHOD)

#### Installation Notes:

- The HRV must be balanced.
- Unit should be balanced on high speed with the furnace blower on.
- It is mandatory that the furnace blower run continuously or HRV operation be interlocked with the furnace blower.
- The duct configuration may change depending on the HRV model.
- A backdraft damper is recommended in the exhaust air duct to prevent outdoor air from entering the unit.
- The airflow must be confirmed on site using the balancing procedures found in this guide.

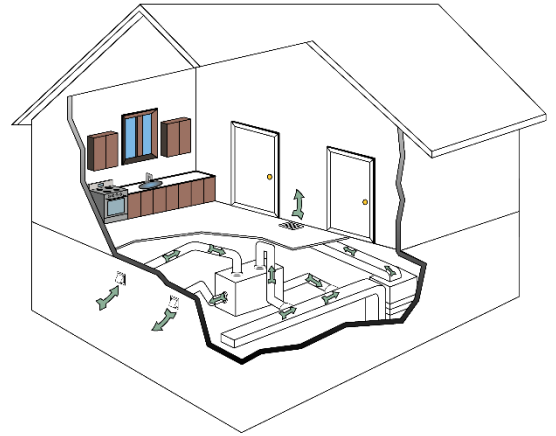

#### Spring-Loaded Backdraft Damper (recommended):

Install the Backdraft Damper with the leaf hinge vertical. The damper is installed on the "Stale Air to Outside" Collar.

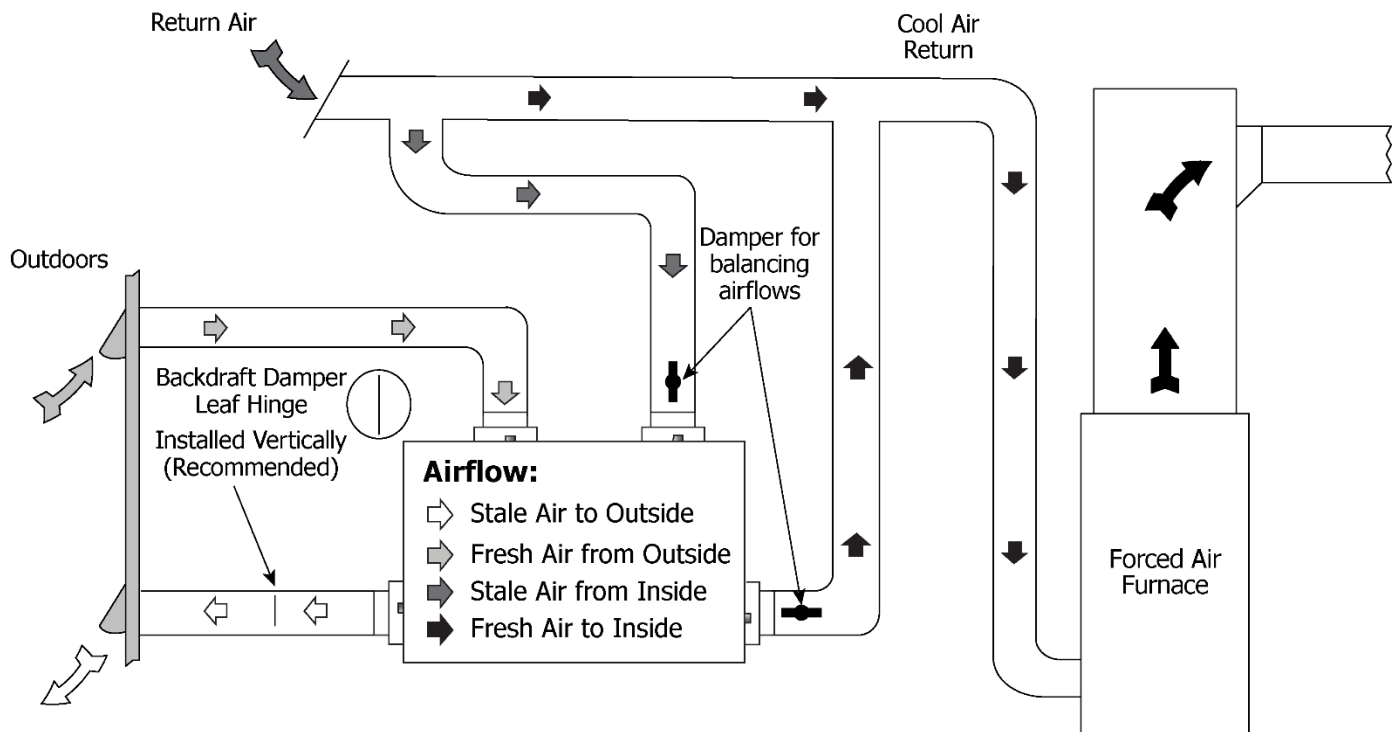

## Warning

- Check local codes/authority having jurisdiction for acceptance.
- Applications such as greenhouses, atriums, swimming pools, saunas, etc. have unique ventilation requirements which should be addressed with an isolated ventilation system.
- Weatherhood arrangement is for drawing purposes only. Check local codes/authority having jurisdiction for acceptance.
- Backdraft dampers are recommended for the stale air to outside air duct. This damper prevents outdoor air from entering the HRV during the operation of the furnace/air handler while the HRV is in standby, off, or recirculating.

## 4 PARTIALLY DEDICATED SYSTEM INSTALLATION

### Installation Notes:

- The HRV must be balanced.
- Unit should be balanced on high speed with the furnace blower on.
- It is recommended that the furnace blower run continuously or HRV operation be interlocked with the furnace blower. Refer to building code.
- The duct configuration may change depending on the HRV model.
- A backdraft damper is recommended in the exhaust air duct to prevent outdoor air from entering the unit.
- The airflow must be confirmed on site using the balancing procedures found in this guide.

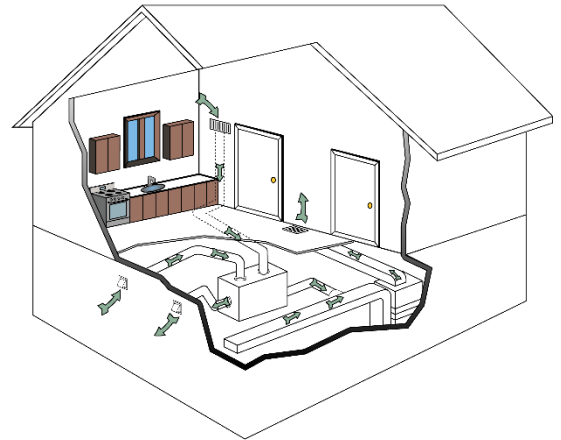

### Spring-Loaded Backdraft Damper (recommended):

Install the Backdraft Damper with the leaf hinge vertical. The damper is installed on the "Stale Air to Outside" Collar.

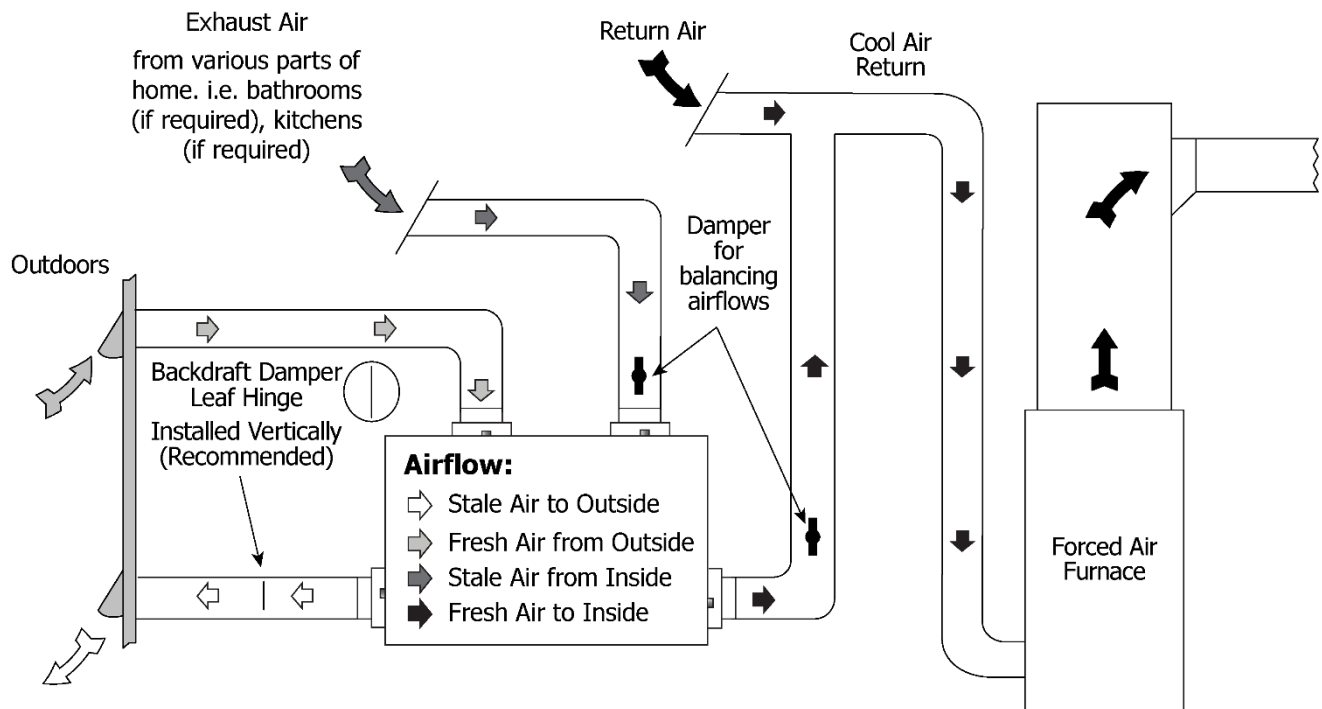

## Warning

- Check local codes/authority having jurisdiction for acceptance.
- Applications such as greenhouses, atriums, swimming pools, saunas, etc. have unique ventilation requirements which should be addressed with an isolated ventilation system.
- Weatherhood arrangement is for drawing purposes only. Check local codes/authority having jurisdiction for acceptance.
- Backdraft dampers are recommended for the stale air to outside air duct. This damper prevents outdoor air from entering the HRV during the operation of the furnace/air handler while the HRV is in standby, off, or recirculating.

## 5 FULLY DEDICATED SYSTEM INSTALLATION

### Installation Notes:

- The HRV must be balanced.
- When balancing, all external exhaust systems should be turned off (i.e., range hood, exhaust, bathroom vents).
- All exhausting appliances should have their own make-up air, as this is not as intended use for the HRV system.
- The duct configuration may change depending on the HRV model.
- The airflow must be confirmed on site using the balancing procedures found in this guide.

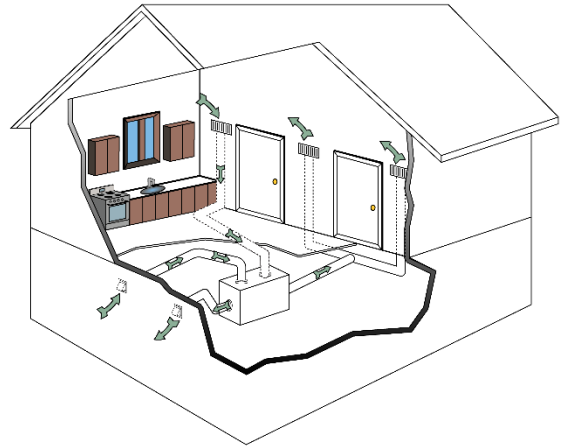

### Spring-Loaded Backdraft Damper (recommended):

There is a location for an optional Backdraft Damper with the leaf hinge vertical. The damper is installed on the "Stale Air to Outside" Collar.

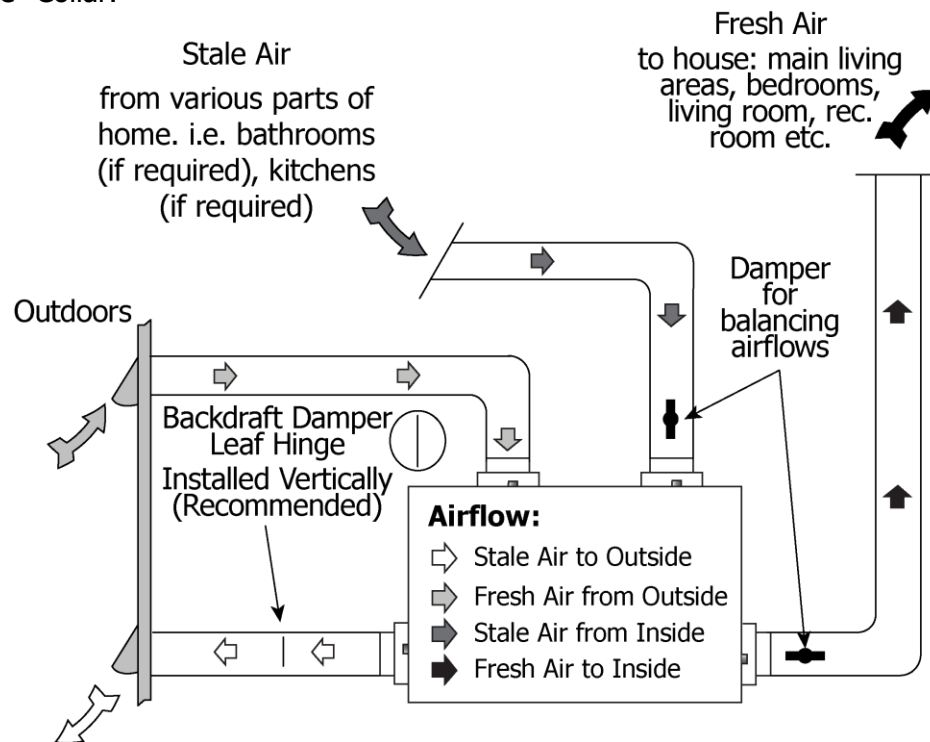

## Warning

- Check local codes/authority having jurisdiction for acceptance.
- Applications such as greenhouses, atriums, swimming pools, saunas, etc. have unique ventilation requirements which should be addressed with an isolated ventilation system.
- Weatherhood arrangement is for drawing purposes only. Check local codes/authority having jurisdiction for acceptance.
- Backdraft dampers are recommended for the stale air to outside air duct. This damper prevents outdoor air from entering the HRV during the operation of the furnace/air handler while the HRV is in standby, off, or recirculating.

## 6 DEFAULT & OPTIONAL DUCT CONFIGURATIONS (195DCS)

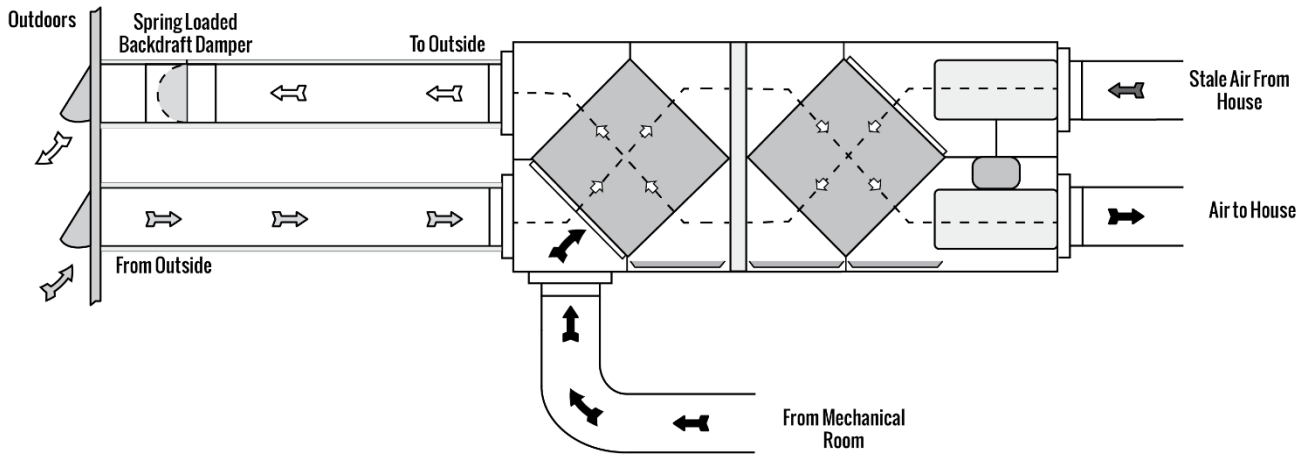

**Figure A – Factory Default Duct Configuration**

**Note:** DIP Switch #2 must be set to "OFF" position (factory default) to disable recirculation operation mode on the controller.

During defrost mode, a damper closes off the air from outside port, which opens the 5th port and allows air to enter the unit from the mechanical room.

### Attention

- Figure A ducting configuration can lead to negative pressure in the mechanical room during defrost mode.

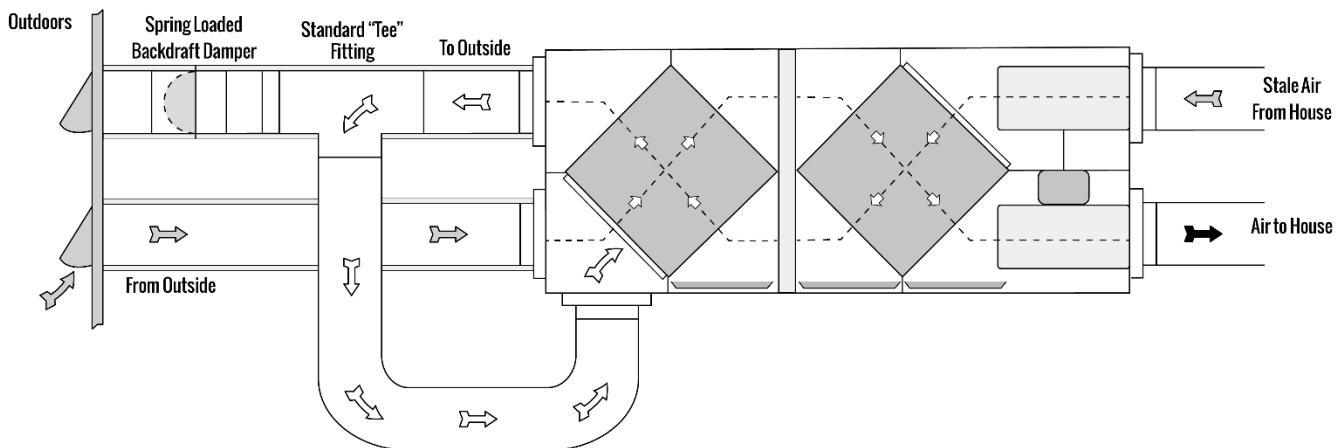

**Figure B – Optional Duct Configuration**

**Note:** DIP Switch #2 must be set to "ON" position to enable recirculation operation mode on the controller.

During defrost mode, a damper closes off the air from outside port, which opens the 5th port and allows the exhaust air to recirculate through the unit. Therefore, the unit operates as a recirculation defrost unit.

## 7 MOUNTING (RNC4-TPD, RNC4-TPF, & RNC 88)

### Mounting the RNC4-TPD & RNC4-TPF:

(1) Mounting Points

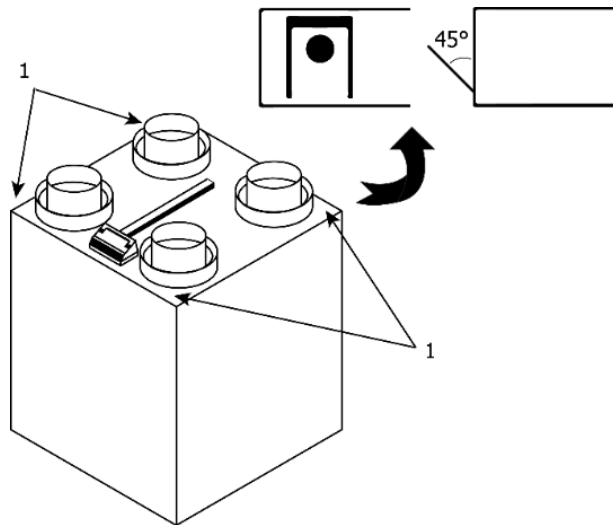

1. Locate the four mounting tabs on the left and right sides of the unit, at the front and back.
2. Using a flat head screwdriver, bend out the four tabs to approximately 45 degrees.
3. Once the tabs have all been bent outwards, insert the "S" hooks through the four holes on the tabs.
4. Install the unit to the structure. Refer to [Hanging Straps](#).

### Mounting the RNC 88:

(1) Mounting Points

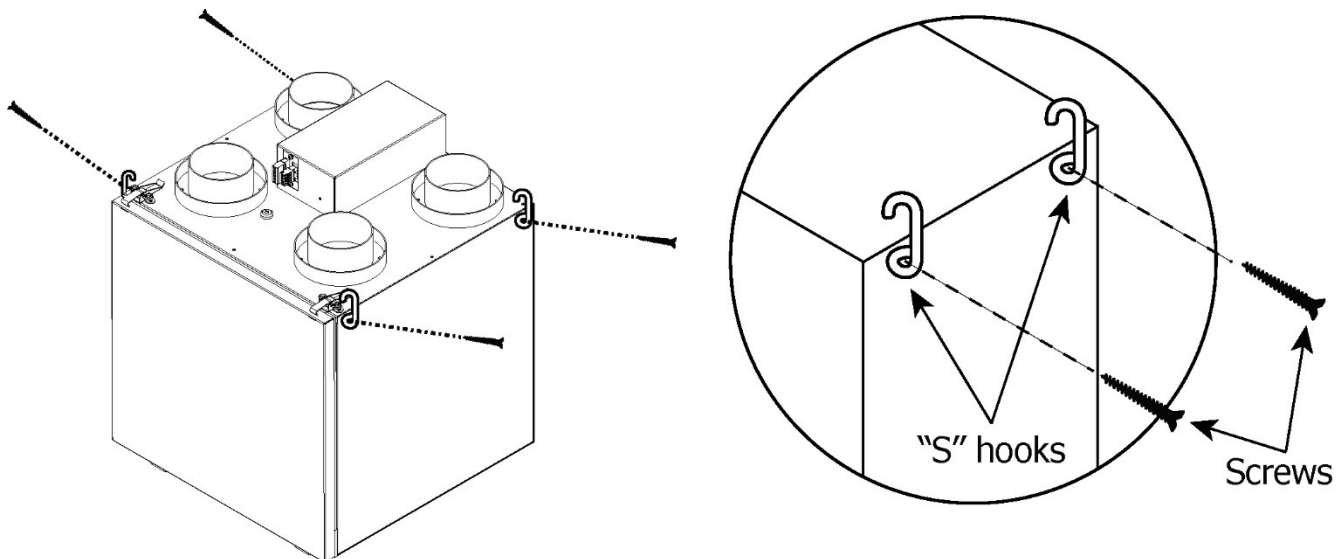

1. Mounting locations on RNC 88 uses standard mounting hardware, same as other RNC HRVs.
2. Install the unit to the structure. Refer to [Hanging Straps](#).



### Attention

- Do not drill additional holes in the HRV

# 8 HANGING STRAPS

## Location:

Install the unit in a heated space that provides convenient space for service access. A typical location is in either a mechanical room or an area close to the outside wall within close proximity to where the weatherhoods are mounted. If a basement area is inconvenient or non-existent, install the unit in a utility or laundry room.

Attic installations are not recommended due to:

- A. the complexity of work to install
- B. freezing conditions in the attic
- C. difficulty of access for servicing and cleaning

Leave sufficient clearance at the front of the access door for servicing the air filters and core. The recommended clearance is a minimum of 25" (635 mm) for opening and closing the door. Four straps have been provided for hanging the unit from the basement floor joists.

## Suspend Unit with Adjustable Hanging Straps

Use 4 screws and 4 washers (not included) to attach the hanging straps to the floor joists. The washer must be wider than the eyelet of the grommet on the hanging strap.

By design, the adjustable hanging straps reduce the possibility of noise, resonance and harmonics.

### STEP 1

Insert the screws and washers (not included) through the Hanging Strap grommets and fasten to the joists.

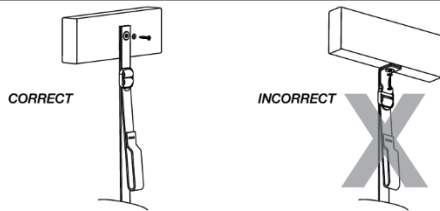
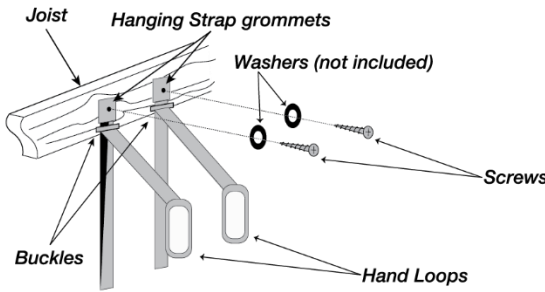

### STEP 2

Unscrew the 4 machine screws located on the upper side of the unit. Attach the "S" hooks and reinsert the machine screws.

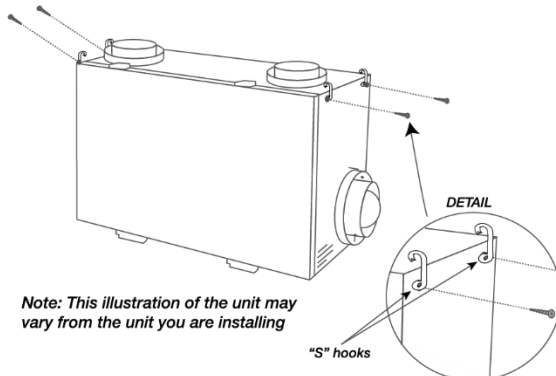

Note: This illustration of the unit may vary from the unit you are installing

### STEP 3

Hook the bottom grommets of the straps through the "S" hooks. Pull down vertically on the hand loops while lifting up the bottom of the cabinet. Repeat at opposite end of the unit.

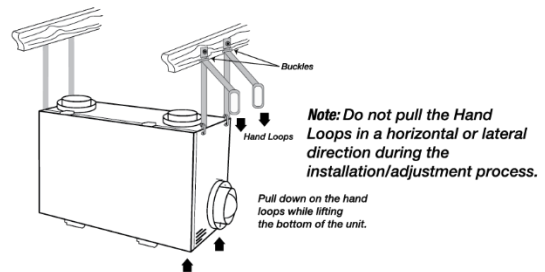

### STEP 4

Level the unit from left to right and front to back.

- Adjust the unit down by lifting up on the buckle.
- Adjust the unit up by pulling down vertically on the Hand Loops while lifting up the bottom of the cabinet.

### STEP 5

Hang the unit on the bracket and ensure that it is level from front to back and left to right.

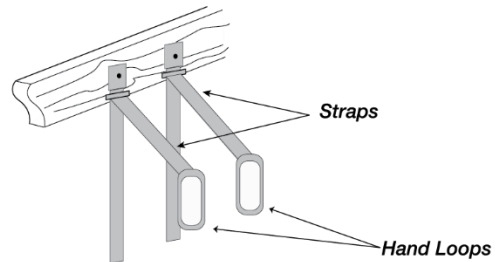

### WARNING

Improper installation, adjustment, alteration, service or maintenance can cause property damage, personal injury or loss of life. Installation and service must be performed by a qualified installer or service agency.

### CAUTION

Unit must be installed level to ensure proper condensate drainage. Due to the broad range of installation and operational conditions, consider the possibility of condensation forming on either the unit or connecting ducting. Objects below the installation may be exposed to condensate.

## 9 DRAIN CONNECTION

The HRV cabinet has pre-punched holes for the drain. The HRV may produce some condensation during a defrost cycle. This water should flow into a nearby drain or be taken away by a condensate pump.

### Figure Callouts:

- (1) Drain Spout
- (2) Drain Pan
- (3) Nut
- (4) Tee Connector
- (5) 1/2 in. Drain Hose
- (6) Drain Line
- (7) Zip Tie
- (8) Washer
- (9) O-Ring

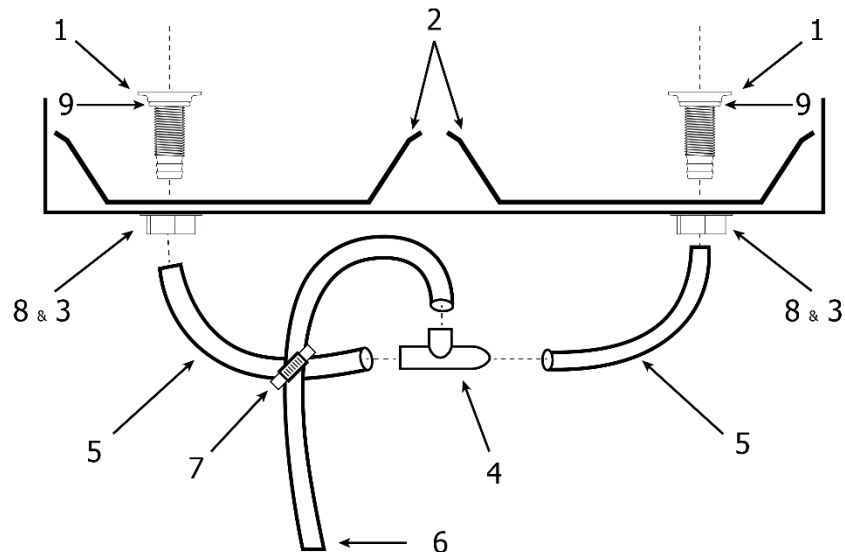

### Installation Steps:

1. Insert the drain spout through the hole in the drain pan.  
**For the RNC4-TPD units, use the drain spout with the foam gasket only.**  
**For RNC88/195DCS units, place O-ring onto drain spout before inserting it through the drain pan hole.**

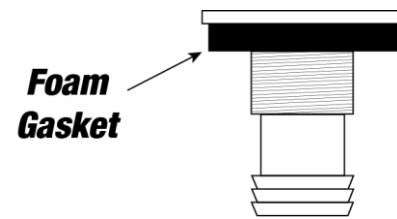

RNC4-TPD Connection Only

2. Install washer and nut on the drain spout. Tighten the nut. **For the RNC4-TPD units, hand-tighten the nut only.**
3. Construct a P-trap using the plastic tee connector.
4. Cut two lengths of 1/2 in. drain hose (not included) and connect the ends to the two drain spouts and the other ends to the plastic tee connector.
5. Position the tee connector to point upward and connect the drain line. Use a zip tie to secure the drain line to one of the 1/2 in. drain hoses.
6. Tape or fasten base to avoid any kinks.
7. Pour a cup of water into the drain pan of the HRV after the drain connection is complete. This creates a water seal which will prevent odours from being drawn up the hose and into the fresh air supply of the HRV.



## Caution

- The HRV and all condensate lines must be installed in a space where the temperature is maintained above the freezing point or freeze protection must be provided.
- Drain trap and tubing must be below bottom of door with 1/4 in. per foot downwards slope away from unit.
- Under certain conditions, a secondary drain pan may be required to protect from condensate leakage.

# 10 GRILLES

## Installation Notes:

Adjustable grilles should be used to balance the flow rates into and out of various rooms. The grilles should not be adjusted after balancing the unit.

Grilles or diffusers should be positioned high on the wall or in the ceiling. Kitchen exhaust should never be connected to the range hood. They should be installed at least 4 ft (1.2 m) horizontally away from the stove.

Field supplied balancing dampers should be installed external to the unit to balance the amount of stale air being exhausted with the amount of fresh air being brought into the house. Refer to airflow balancing section.

## The Kitchen Grille

The Kitchen Grille includes a removable grease filter. Most building codes require that kitchen grilles are equipped with washable filters.

- Part# 99-10-002, 6 in x 10 in

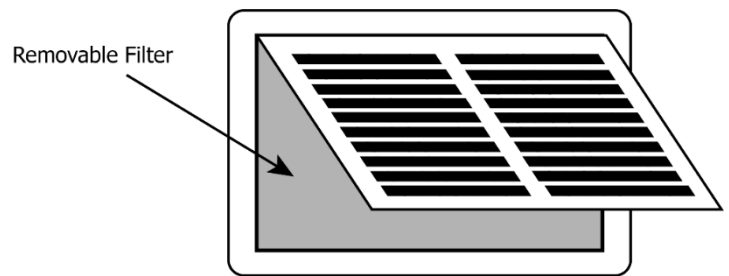

## The TechGrille

The TechGrille is a round, fully adjustable grille, which provides quiet air distribution.

- Part # 99-EAG4, 4 in (100 mm)
- Part # 99-EAG5, 5 in (125 mm)
- Part # 99-EAG6, 6 in (150 mm)
- Part # 99-EAG8, 8 in (200 mm)

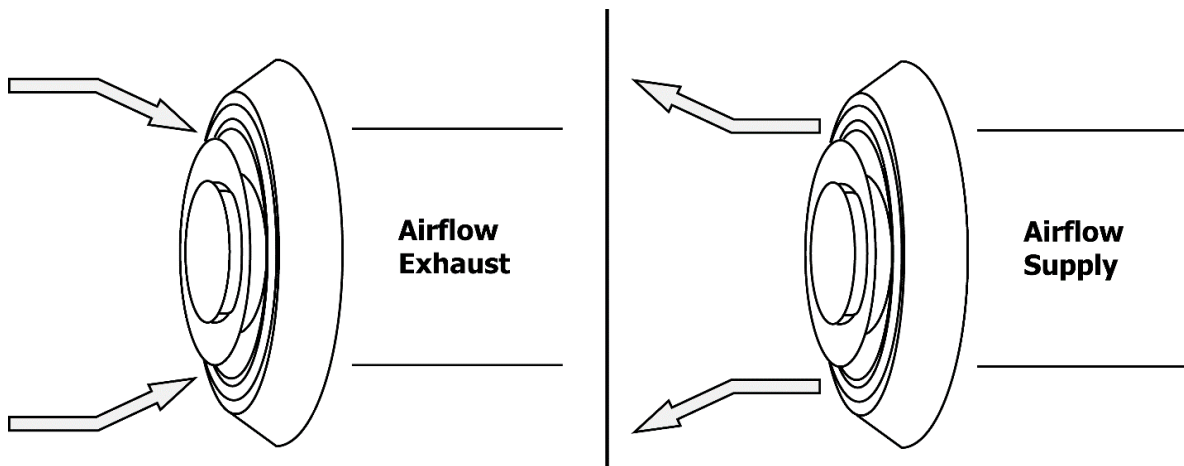

# 11 GRILLE FITTINGS

## Quick Mount Fitting (Part# 99-QM6)

- Use this rough-in fitting before the drywall is installed.
- Nail fitting onto the stud.
- Available size: 6 in.

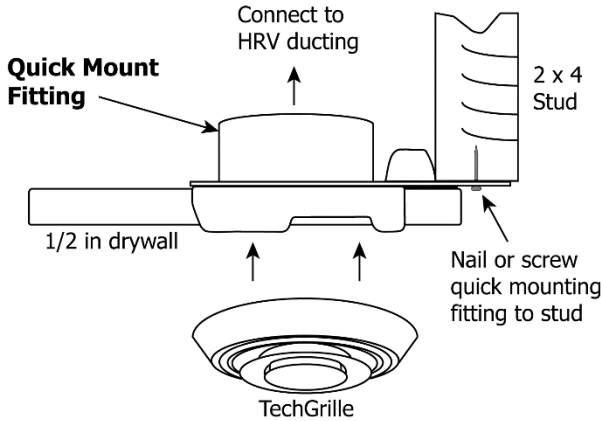

## Terminator Fitting (Part# 99-TM 4/5/6)

- Use this rough-in fitting before the drywall is installed.
- Nail or screw fitting onto the stud or joist.
- Available sizes: 4 in, 5 in, and 6 in.
- Adapts to ridged and flex ducting
- Strong attachment for grilles, either vertically or horizontally.

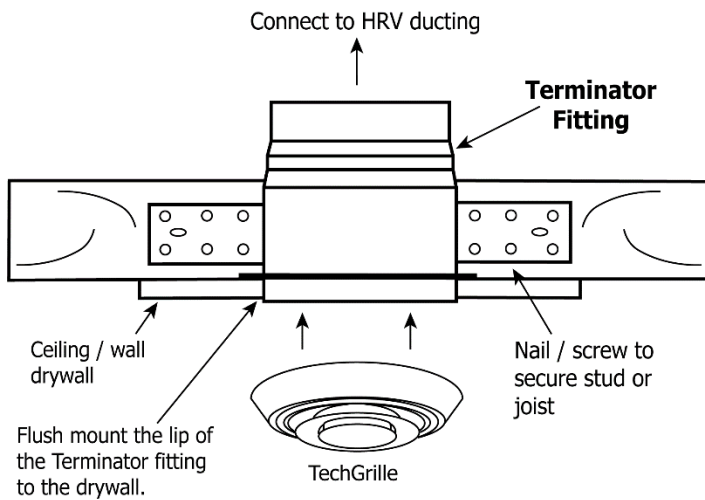

## Stack Head Elbow (Part# 99-WF 4/6)

- Use this rough-in fitting before the drywall is installed.
- This fitting is ideal for running ducting through 2 x 4 (min.) studded walls.
- Nail to stud.
- Available sizes are 4 in. and 6 in.

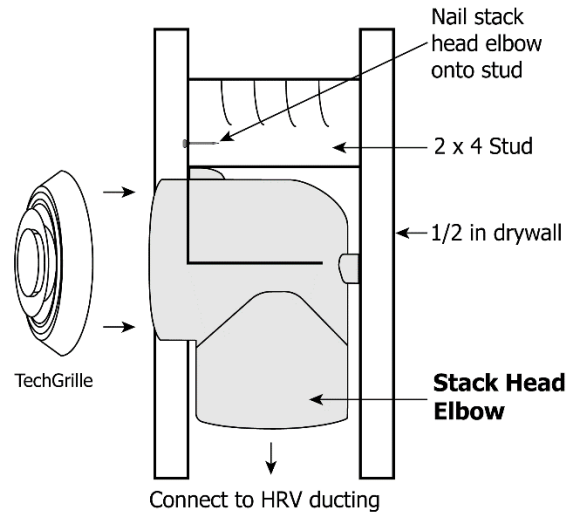

## Suspended Ceiling Fitting (Part# 99-CF6)

- Use this fitting for ceiling tiles or finished/installed drywall.
- Cut a hole through the ceiling tile, insert the fitting and use the retaining ring to hold the fitting in place.
- For finished/installed drywall, use caulking around the lip if you do not have access to attach the retaining ring.
- Available size: 6 in.

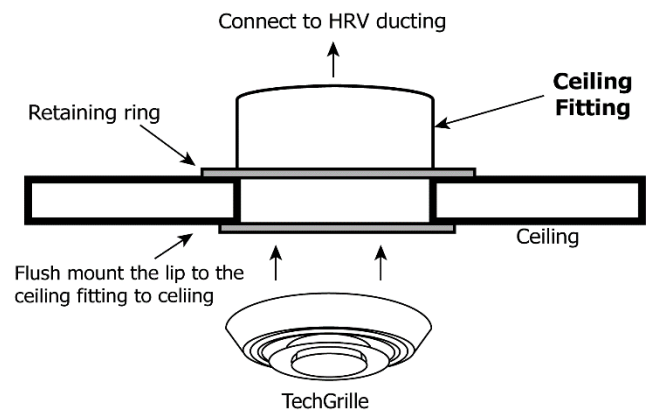

## Caution

- Do not mount exhaust grille within 4 ft (1.2 m) (horizontally) of a stove to prevent grease from entering the unit.

## 12 LIFE BREATH WEATHER HOODS

Fixed covered weather hoods have a built-in bird screen with a 1/4 in. (6 mm) mesh to prevent foreign objects from entering the ductwork.

### Installation Notes:

- The inner and outer liners of the flexible insulated duct must be clamped to the sleeve of the weatherhoods (as close to the outside as possible) and the appropriate port on the HRV. It is very important that the fresh air intake line be given special attention to make sure it is well sealed. A good bead of high-quality caulking (preferably acoustical sealant) will seal the inner flexible duct to both the HRV port and the weatherhood prior to clamping.
- The flexible insulated duct that connects the two outside weatherhoods to the HRV should be stretched tightly and be as short as possible to minimize air flow restrictions.
- Twisting or folding the duct will severely restrict airflow.
- Hard (rigid) ducting which has been sealed and insulated should be used for runs over 10 ft (3.3 m). Refer to your local building code.

### Figure Callouts:

- (1) Thermal Collar
- (2) 12 in. long Galvanized Sleeve
- (3) Exterior Wall
- (4) 1/4 in. (6mm) Mesh Screen

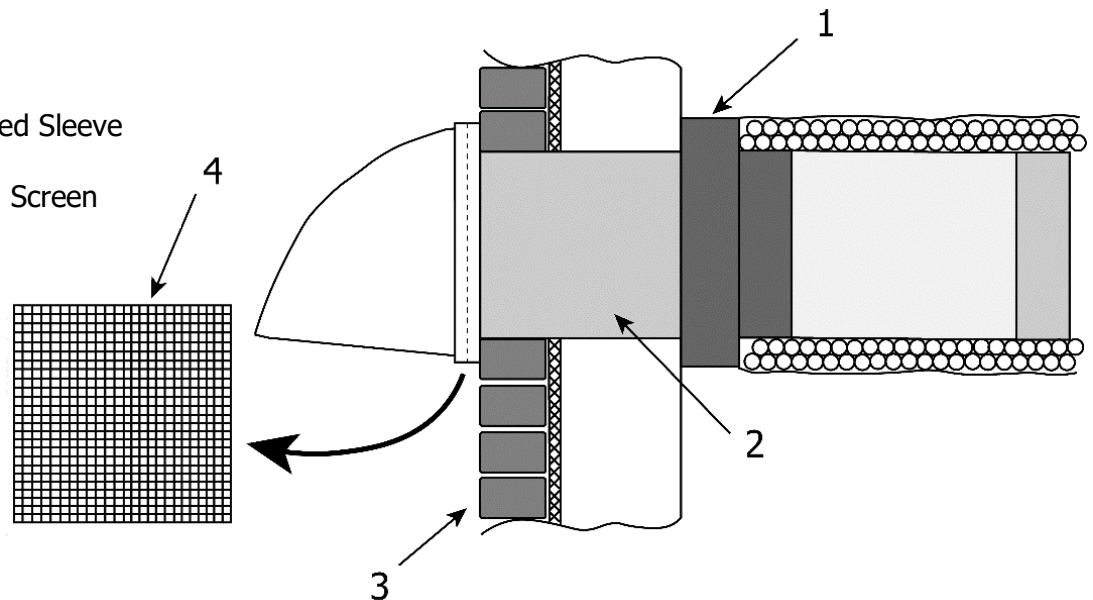

### Installation Steps:

1. Thermal collar slides over galvanized sleeve to ensure vapor barrier is 100% sealed to wall plate.
2. Fasten thermal collar to belt.
3. Slide the insulated flexible ducting over galvanized sleeve and fasten it to the thermal collar.
4. Weatherhood is hinged to allow for easy access for cleaning of mesh screen.



## Attention

- **Weather Hood Requirements:** Check local codes/authority having jurisdiction for acceptance and space requirements for weatherhoods. Do not locate in garage, attic, or crawl space.
  - i) **Intake:** Should be located upstream (if there are prevailing winds) from the exhaust outlet. Not near dryer vents, furnace exhaust, driveways, oil fill pipes, gas meters, or garbage containers.
  - ii) **Exhaust:** Not near a gas meter, electric meter or a walkway where fog or ice could create a hazard.

## 13 LIFE BREATH DUAL HOOD

The Lifebreath Dual Hood only requires one 6 in. opening for intake and exhaust. The Lifebreath Dual Hood can be used up to a maximum airflow of 140 cfm.

### Available Units:

- 99-194 – 4 in. Dual Hood (not shown)
- 99-190 – 5-6 in. Dual Hood

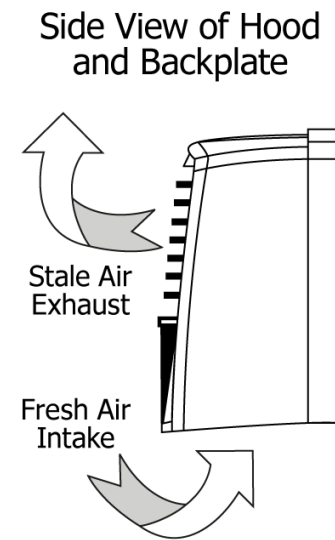
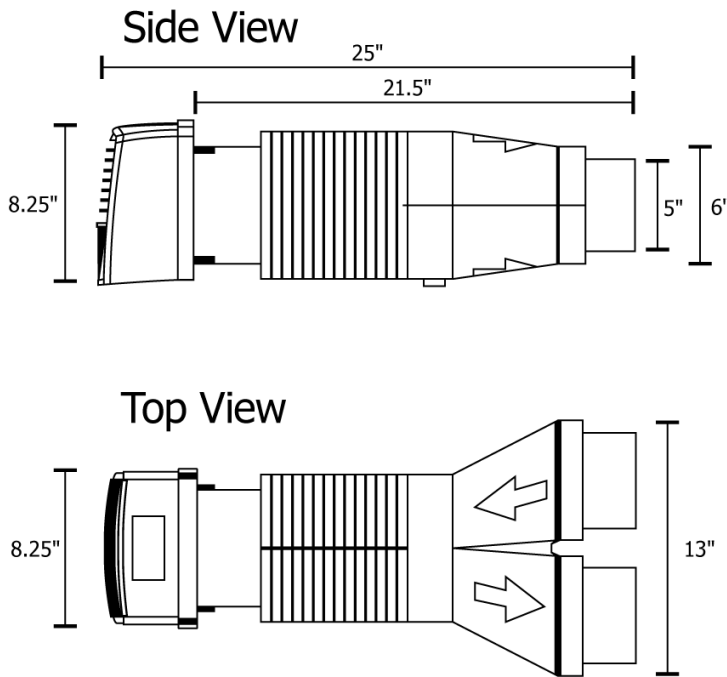

### Caution

- Sealant must be applied as per instructions or leakage and condensation may occur.
- Insulate the Fresh Air Supply and Stale Air Exhaust duct work back to the unit.



### Attention

- Contact your local building authority before installation of the Dual Hood to verify compliance with local building codes.



### Note

- Tested by: National Research Council Canada
- Program: Building Regulations for Market Access Report Number: A1-007793
- Report Date: 15 February 2016
- Found to comply with requirement as set in the NBC.

# 14 TERMINAL BLOCKS

Each unit has a Terminal Block. The Terminal Block will either be Type A or Type B, shown below.

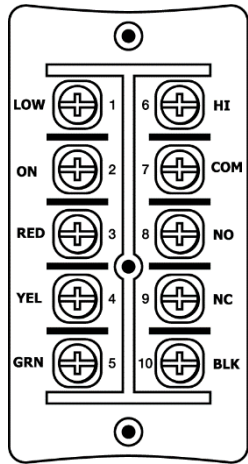

Type A - TB01:Terminal Block

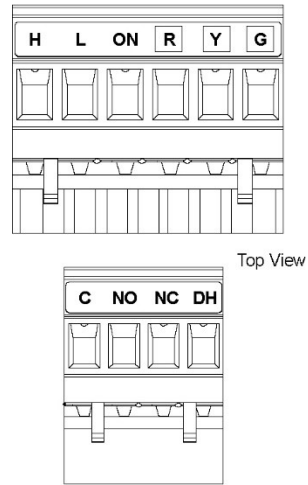

Type B - TB04:Terminal Block

# 15 MAIN CONTROL INSTALLATION (99-DXPL03)

The 99-DXPL03 main control must be surface mounted onto a wall. Only one main control should be installed into a ventilation system.

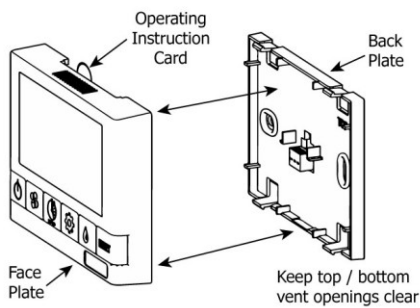

Figure A

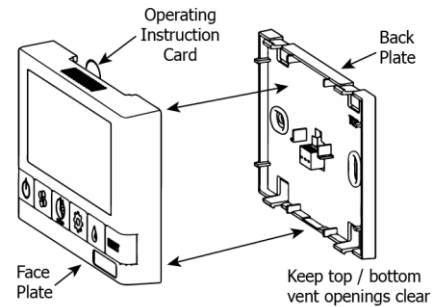

Figure A

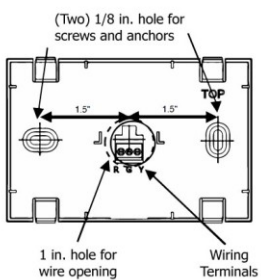

Figure B

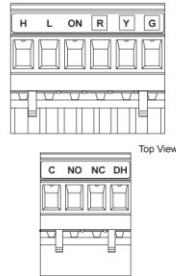

Figure C

DXPL03 with TB04 Terminal Block

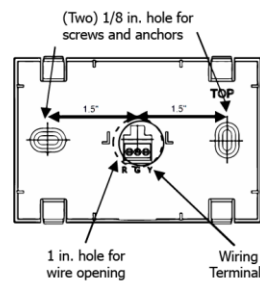

Figure B

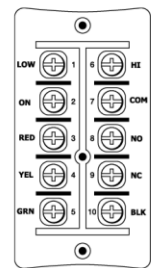

Figure C

DXPL03 with TB01 Terminal Block

## Installation:

1. Remove the operating instructions card from the top of the main control (figure A).
2. Carefully separate the face plate and the back plate by firmly pulling it apart (figure A).
3. Position the back plate of the control in the desired location on the wall and mark the wall for the desired screw holes (figure B).
4. Remove the back plate from the wall and mark the hole for the wires in between the two screw holes (figure B).
5. Drill two holes for the screws and wall anchors and drill one hole for the wires in between the two screw holes (figure B).
6. Pull the 3 wire 20 gauge (min.), 100 ft length (max.), through the opening in the wall.
7. Connect the wires to the R, G, and Y terminals on the back plate (figure B).
8. Using the two supplied screws and anchors, install the back plate on the wall.
9. Attach the face plate to the back plate (figure A).
10. Install the operating instructions card in the top of the main control (figure A).
11. Connect the 3 wires 20 gauge (min.), 100 ft length (max.), to the 3 (RED), 4 (YEL), and 5 (GRN) terminals located on the HRV terminal block (figure C).

## Attention

- Use care when separating or attaching the face plate to avoid damaging the contact pins.

# 16 MAIN CONTROL INSTALLATION (99-BC02/3/4)

The 99-BC02, 99-BC03, 99-BC04 ventilation controls may either be installed onto a flush mounted electrical switch box or surface mounted onto a wall. Only one main control should be installed into a ventilation system.

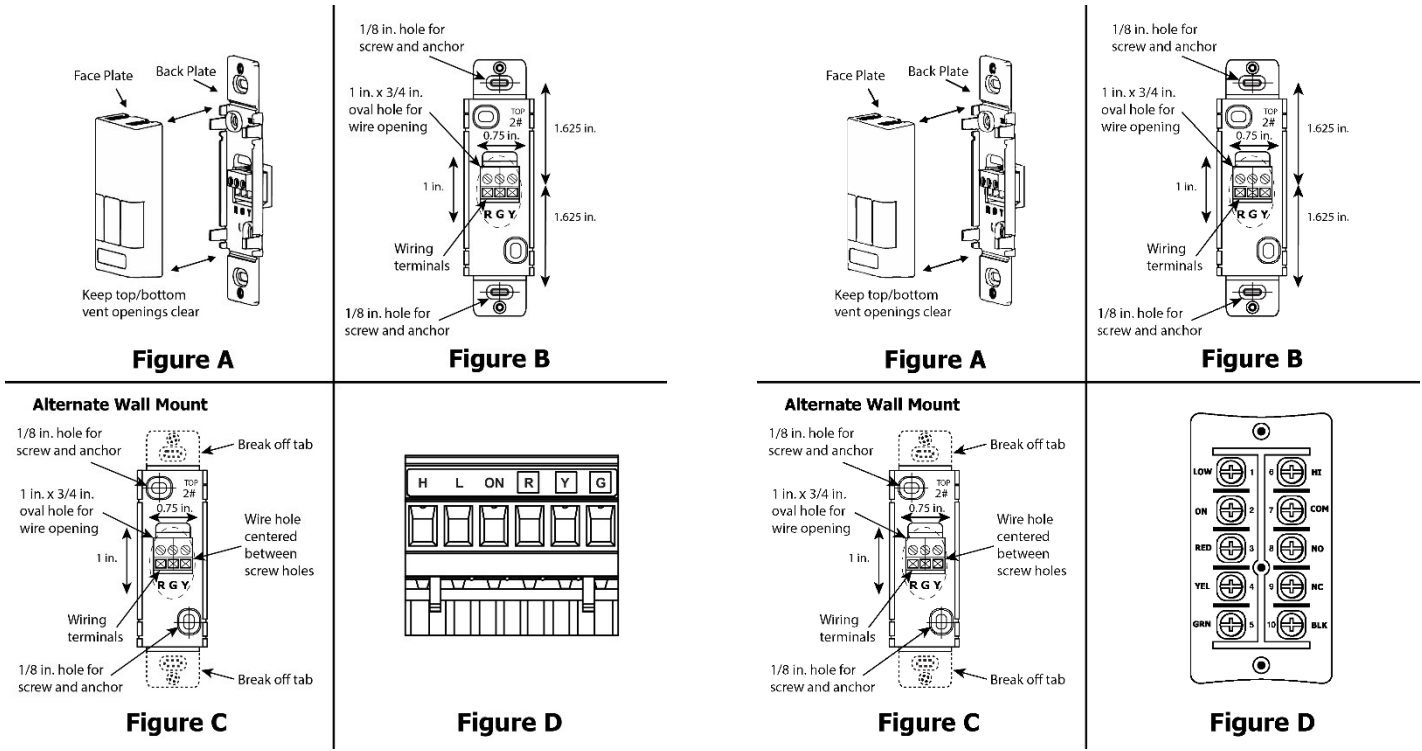

BC02/03/04 with TB04 Terminal Block

BC02/03/04 with TB01 Terminal Block

**Installation:**

- Carefully separate the face plate and the back plate by firmly pulling it apart. Keep the top/bottom vent openings clear (figure A).
- Position the back plate in the desired location on the wall and mark the wall for the desired screw holes (figure B).
- For mounting the main control without a Decora plate, break off the top and bottom tabs than position the back plate in the desired location on the wall and mark the wall for the desired screw holes (figure C)
- Remove the back plate from the wall and mark the hole for the wires centered between the two screw holes (figure B or C).
- Drill two 1/8 in. holes for the screws and wall anchors and drill one 1 in. x 0.75 in. hole for the wires.
- Pull the 3 wire 20 gauge (min.), 100 ft length (max.), through the opening in the wall.
- Connect the wires to the R, G, and Y terminals on the back plate (figure B or C).
- Using the two supplied screws and anchors, install the back plate on the wall.
- Attach the face plate to the back plate (figure A).
- Connect the 3 wires 20 gauge (min.), 100 ft length (max.), to the 3 (RED), 4 (YEL), and 5 (GRN) terminals located on the HRV terminal block (figure D).

**Attention**

- Use care when separating or attaching the face plate to avoid damaging the contact pins.

# 17 INTERLOCKING THE HRV

## Interlocking the HRV to a Furnace/Air Handler

Connecting the HRV as shown below will ensure that the air handler/furnace blower motor is operating whenever the HRV is venting.

- The HRV must be interlocked to the furnace/air handler with a [Simplified Installation \(Return/Return Method\)](#).
- The HRV should be interlocked to the furnace/air handler with a [Partially Dedicated System Installation](#).

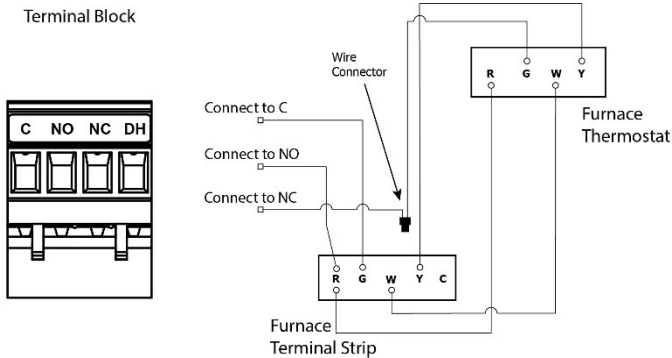

Air Handler/Furnace Blower  
Connections with TB04 Terminal Block

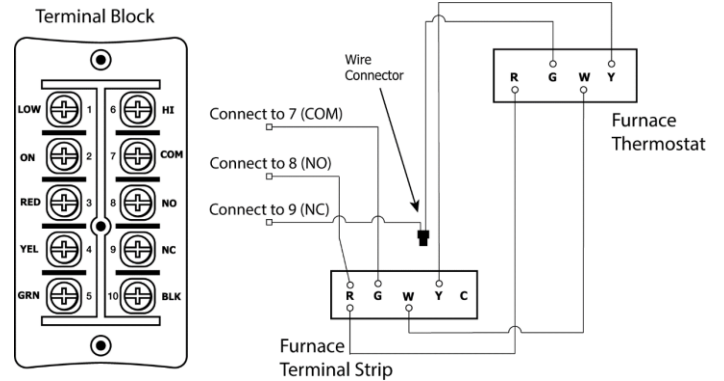

Air Handler/Furnace Blower  
Connections with TB01 Terminal Block



### Caution

- Consideration should be given to competing airflows when connecting the HRV in conjunction with an air handler/ furnace blower system.

# 18 ADDITIONAL CONTROLS

## Setting "Standby" When Using the Main Control

The ERV will be "fully-off" when selected on the main control. Timers and/or other controls will not function when the ERV is in off position.

The "fully-off" feature can be modified to "standby-off" by adding a jumper on the ERV terminal block between 2 (ON) and 3 (RED) terminals. "Standby" can also be achieved by setting the main control to the on position and selecting speed 0. Timers and/or additional controls will initiate high speed ventilation when activated.

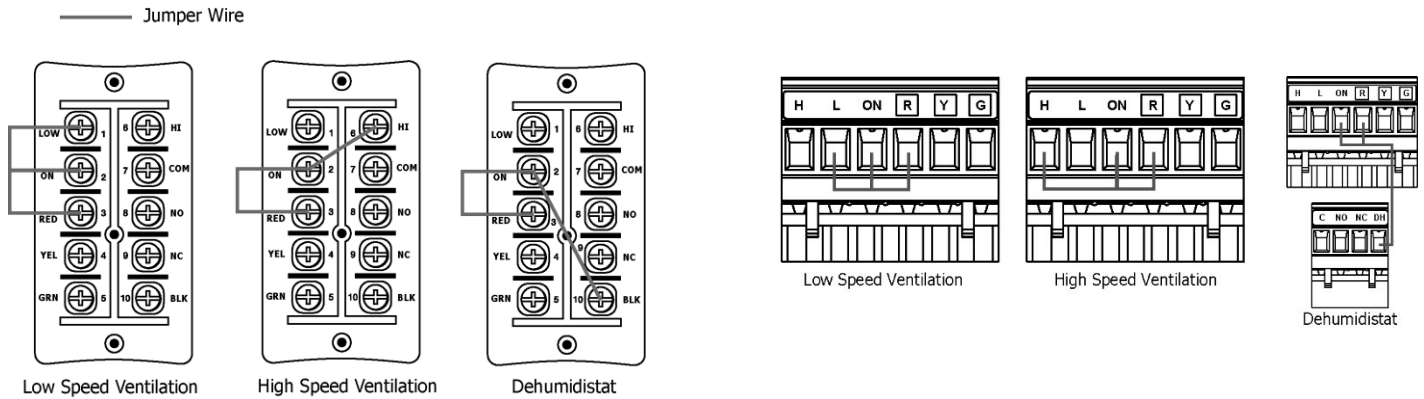

Type A - TB01:Terminal Block

Type B - TB04:Terminal Block

## Adding Dry Contact Controls

A jumper must be placed between 2 (ON) and 3 (RED) terminals on the ERV terminal block to activate the ERV for timers and/or dry contact controls, or if installing the unit without a main control. Jumpers can be added between terminals on the ERV terminal block for additional controls, per the table below:

Setting	Terminals	
Low Speed Ventilation	ON	LOW
High Speed Ventilation	ON	HI or H
Dehumidistat	ON	BLK or DH

### Caution

- Building codes in some areas require "fully-off" functionality. Check with your local building authority before modifying the unit to "standby-off". Unintentional operation of the ERV by the end user may occur if the unit is modified from "fully-off" to "standby-off".

# 19 TIMERS

## 20/40/60 Minute Timer (99-DET01)

Connect the wires from the Y, R, and G terminals on the timer to the 4 (YEL), 3 (RED), and 5 (GRN) terminals on the HRV terminal block as shown. A jumper between Red and On is required when not using a de-humidistat.

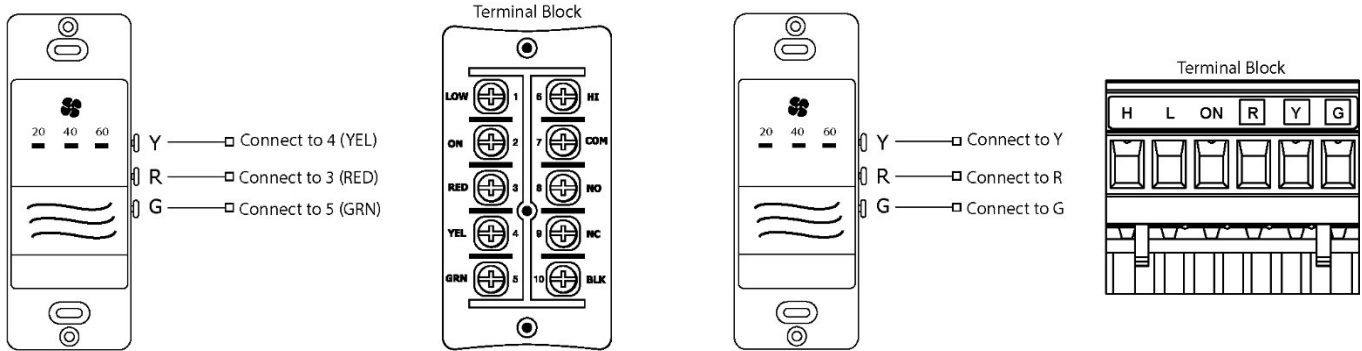

DET01 Timer with TB01 terminal block

DET01 Timer with TB04 terminal block

## Mechanical Timers Installation (99-101)

The Mechanical Timer is a 2 wire "dry contact" timer. Connect a jumper wire between the 2 (ON) and 3 (RED) terminals on the HRV terminal block and connect the two timer wires to the 2 (ON) and 6 (HI) terminals on the HRV terminal block as shown.

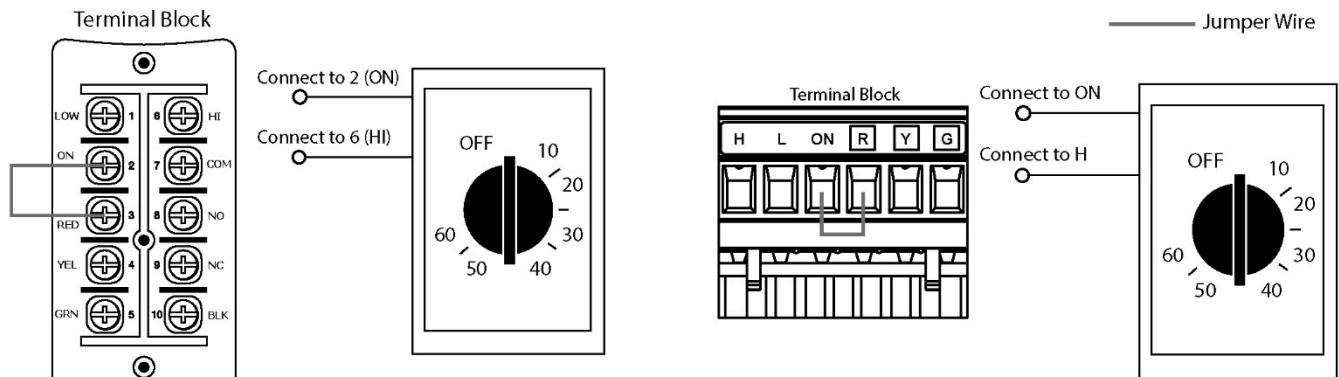

Dry Contacts Connections with TB01 terminal block

Dry Contacts Connections with TB04 terminal block

### Attention









- Timers mount in standard electrical boxes.
- Use 3 wire 20 gauge (min.) 100 ft length (max.) low voltage wire and multiple timers individually wired back to the unit.
- **Recommendation:** Use shielded wire to reduce communication noise.

# 19 TIMERS

## Wireless 20/40/60 Minute Timer (99-DET02)

The timers may be installed onto a flush mounted electrical switch box or it may be surfaced mounted onto a wall.

### Pairing:

1. Remove the battery from the back of the timer, if installed.
2. Press the ON/OFF Button  on the main control to turn it on.
3. **DXPL03:** Press the left and right buttons ( and ) simultaneously on the main control. The screen will go blank, and the wireless symbol  will appear flashing on the bottom right of the display. This indicates that the main control is now in pairing mode.
4. **BC02, BC03, or BC04:** Press the left and right buttons ( and  or ) simultaneously on the main control. The bottom row LEDs will begin flashing. This indicates the main control is now in pairing mode.
5. Keep the timer within 16 in. of the main control when pairing.
6. Install the battery into the remote timer. The four lights will immediately flash five times. The red battery light will remain on for 12 seconds, then the 40 minute status light will flash. The 20, 40, and 60 minute status lights will flash for up to 30 seconds and then stop.
7. Press the Power Button  on the main control to exit pairing mode.
8. Press the Select Button on the timer to test that pairing was successful (figure A).
  - If the HRV initiates HIGH fan speed ventilation, pairing was successful.
  - If the HRV does not initiate HIGH fan speed ventilation, pairing was not successful. Un-pair the timer and return to step 1 of the pairing procedure and restart the pairing process.
9. Pair additional timers as necessary by repeating steps 1 through 8.

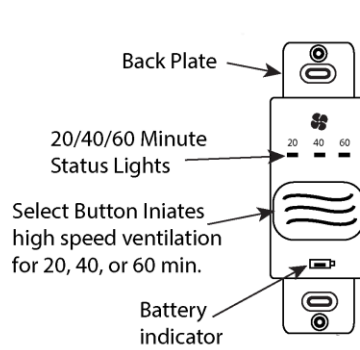

Figure A

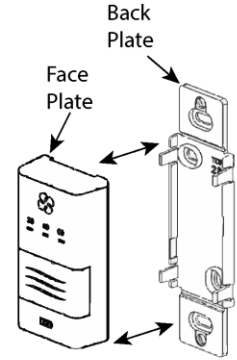

Figure B

### Alternate Wall Mount

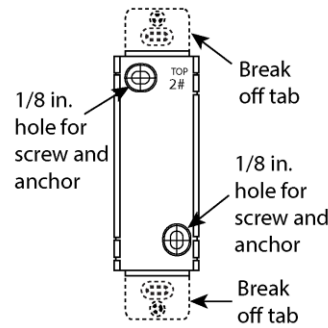

Figure C

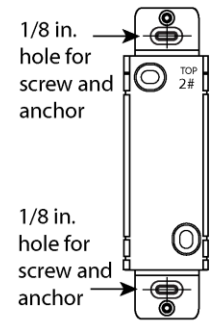

Figure D

### Un-pairing:

1. Remove the battery from the back of the timer.
2. Press and hold the Select Button on the front of the timer (figure A).
3. While holding the Select Button, reinstall the battery in the timer. Continue holding the Select Button until the 20, 40, and 60 minute status light begins flashing (this can take up to 30 seconds). The timer will now be unpaired with the main control (figure A).

### Installation:

1. Separate the face plate from the back plate by firmly pulling apart (figure B).
2. For mounting the main control without a Decora plate, break off top and bottom tabs (figure C).
3. Place the back plate of the main control in the desired location on the wall and pencil mark the top and bottom screw holes. Drill two 1/8" holes (figure C or D).
4. Attach the back plate to the wall using the two supplied screws and anchors.
5. Attach the face plate to the back plate (figure B).



### Attention

- The wireless timers and repeaters must be paired to the main control of the HRV. This process is called "Pairing". Multiple timers and repeaters can be paired to the main control.

## 20 REPEATER

### 99-RX02 Repeater

- (1) Green LED
- (2) Red LED
- (3) Power Plug





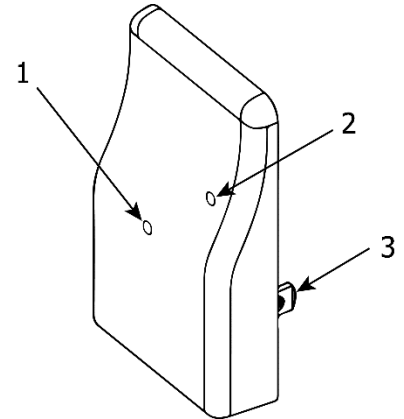

The wireless repeater is used to extend the range of the 99-DET02 wireless timers. The repeater plugs directly into a 120V power outlet. The 99-RX02 repeater wirelessly connects to the main control as well as the 99-DET02 wireless timers.

The 99-RX02 repeater should be installed at the halfway point between the 99-DET02 wireless timer and the main control if the timer is out of range. The LED will indicate the repeater's connection strength to the main control per the table below. Re-adjust the repeater's position as necessary.



LED Colour	Connection	Action
Solid Green	Good	No further adjustments are required.
Flashing Green	Moderate	The repeater will function properly but shouldn't be moved further away from the main control.
Red	Bad	The repeater needs to be moved closer to the main control.

### Pairing:

1. Turn on the main control by pressing the ON/OFF button .
2. **DXPL03 control:** Press the left and right buttons simultaneously on the main control (  and RESET ). The screen will go blank, and the wireless symbol will appear flashing on the bottom right of the display. This indicates that the main control is now in pairing mode.
3. **BC02, BC03 or BC04 control:** Press the left and right buttons simultaneously on the main control (  and  or  ). The bottom row LED's will begin flashing. This indicates that the main control is now in pairing mode.
4. The RX02 Repeater must be powered within 16 in. of the main control for pairing. If an outlet is not available an extension cord should be used to power the Repeater initially for pairing.
5. Plug the repeater into the power outlet. The green light will flash after approximately 12 seconds indicating that the repeater is paired with the main control.
6. Press the ON/OFF button  on the main control to exit pairing mode and the repeater may now be unplugged and moved to its permanent location.
7. To pair additional repeaters with the same main control, repeat steps 1 through 5 until all repeaters have been paired.



### Attention

- The repeaters are to be plugged directly into a 120V power outlet.

# 21 INSTALLER SELECTABLE HIGH SPEED SETTINGS

## Adjusting the DIP Switches

Applicable Units: 195 DCS, RNC4-TPD, RNC4-TPF, and RNC 200.

The circuit board on this unit has adjustable DIP switches for the selection of three different high speeds. The factory setting is Hi3. Refer to [www.lifebreath.com](http://www.lifebreath.com) for the specifications sheet particular to the unit.

### DIP Switch settings

Speed	Switch			
	1	2	3	4
Hi 3 (High Speed)	ON*	Leave on factory setting	ON	ON
Hi 2 (Med Speed)	ON*	Leave on factory setting	OFF	ON
Hi 1 (Low Speed)	ON*	Leave on factory setting	ON	OFF

**Note:** Low Speed is not adjustable; Switch 1 factory setting is ON

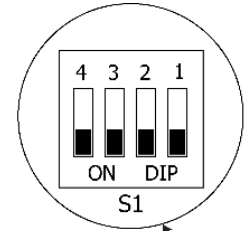

### Functionality of DIP Switches

Switch	Status	Description
2	ON	Recirculation enabled
	OFF	Recirculation disabled

**Note:** Recirculation is not available on all units.

Applicable Units: 155MAX 2019, RNC155 2019, RNC 88, RNC6-ES, 205 MAX, RNC 205, RNC 205 PLUS, RNC5-TPD, RNC5-TPF, RNC5-HEX-TPF, RNC6-HEX-TPD.

The circuit boards on these unit have adjustable DIP switches for the selection of four different high speeds. The factory setting is Hi 3 (Speed 5).

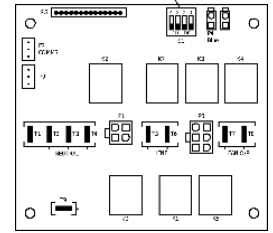

Model Name	Switch 1				Switch 2				Switch 3																				
	DIP 1	DIP 2	DIP 3	DIP 4	DIP 1	DIP 2	DIP 3	DIP 4	DIP 1	DIP 2	DIP 3	DIP 4																	
155MAX 2019	ON	ON	ON	ON	ON	ON	ON	ON	ON	ON	ON	ON																	
RNC155 2019	ON	ON	ON	ON	ON	ON	ON	ON	ON	ON	ON	ON																	
RNC 88	ON	ON	ON	ON	OFF	ON	ON	ON	ON	ON	ON	ON																	
RNC6 ES	ON	ON	ON	OFF	ON	ON	ON	ON	ON	ON	ON	ON																	
205 MAX / RNC 205	ON	ON	ON	OFF	OFF	ON	ON	ON	ON	ON	ON	ON																	
RNC 205 PLUS	OFF	ON	ON	OFF	ON	ON	ON	ON	ON	ON	ON	ON																	
RNC5-TPD	ON	ON	OFF	OFF	OFF	ON	ON	ON	ON	ON	ON	ON																	
RNC5-TPF	ON	ON	OFF	OFF	ON	ON	ON	ON	ON	ON	ON	ON																	
RNC5-HEX-TPF	ON	OFF	ON	ON	OFF	ON	ON	ON	ON	ON	ON	ON																	
RNC6-HEX-TPD	ON	OFF	ON	ON	ON	ON	ON	ON	ON	ON	ON	ON																	
	<b>Switch 1</b> DIP 1, 2, 3 and 4 - Unit selection				<b>Switch 2</b> DIP 1 - Unit selection DIP 2 On - R2000 Defrost cycle disabled DIP 2 Off - R2000 Defrost cycle enabled DIP 3 and 4- Selectable High Speed* <i>* Selectable High Speed</i>				<b>Switch 3</b> DIP 1, 2, 3 and 4 - Null																				
					<table border="1"> <thead> <tr> <th rowspan="2">Speed</th> <th colspan="2">Switch 2</th> </tr> <tr> <th>DIP 3</th> <th>DIP 4</th> </tr> </thead> <tbody> <tr> <td>Hi 3 (Speed 5)</td> <td>ON</td> <td>ON</td> </tr> <tr> <td>Hi 2 (Speed 4)</td> <td>OFF</td> <td>ON</td> </tr> <tr> <td>Hi 1 (Speed 3)</td> <td>ON</td> <td>OFF</td> </tr> <tr> <td>Hi 0 (Speed 2)</td> <td>OFF</td> <td>OFF</td> </tr> </tbody> </table>				Speed	Switch 2		DIP 3	DIP 4	Hi 3 (Speed 5)	ON	ON	Hi 2 (Speed 4)	OFF	ON	Hi 1 (Speed 3)	ON	OFF	Hi 0 (Speed 2)	OFF	OFF				
Speed	Switch 2																												
	DIP 3	DIP 4																											
Hi 3 (Speed 5)	ON	ON																											
Hi 2 (Speed 4)	OFF	ON																											
Hi 1 (Speed 3)	ON	OFF																											
Hi 0 (Speed 2)	OFF	OFF																											

Applicable Units: 267MAX

The circuit board on this unit has adjustable DIP switches dependent on the model features.

Model Name	First Character of Serial Number Alpha Code*	Second Character of Serial Number Alpha Code*	First 6 digits of Unit Serial Number (MMDDYY)*	Switch 2				Switch 1				
				DIP 1	DIP 2	DIP 3	DIP 4	DIP 1	DIP 2	DIP 3	DIP 4	
267MAX	E	-	Prior to 092123	ON	OFF	ON	ON	ON	OFF	OFF	OFF	OFF
			Post 092123	ON	OFF	OFF	ON	OFF	ON	ON	OFF	OFF
	B	-	Prior to 092123	ON	OFF	ON	ON	ON	OFF	OFF	OFF	OFF
			Post 092123	ON	OFF	OFF	ON	OFF	ON	ON	ON	OFF
Switch 2: Dip 1 On - R2000 Defrost cycle disabled Dip 1 Off - R2000 Defrost cycle enabled Dip 2 - Null				Switch 1: Unit Selection								

\*Refer to "Serial Number Nomenclature Breakdown" on page 4.

## 22 DIMENSIONAL DRAWINGS

### RNC4-TPD and RNC4-TPF Dimensions:

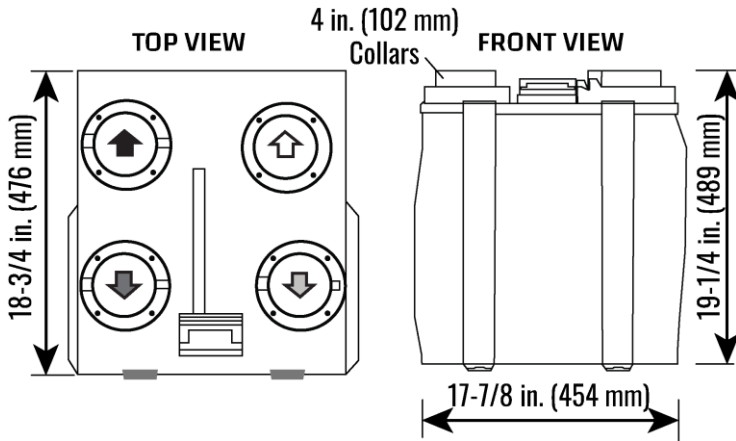

### Airflow:

- ⇨ Stale Air to Outside
- ⇨ Fresh Air from Outside
- ⇨ Stale Air from Inside
- ⇨ Fresh Air to Inside

### RNC5-TPD, RNC5-TPF, and RNC6-ES Dimensions:

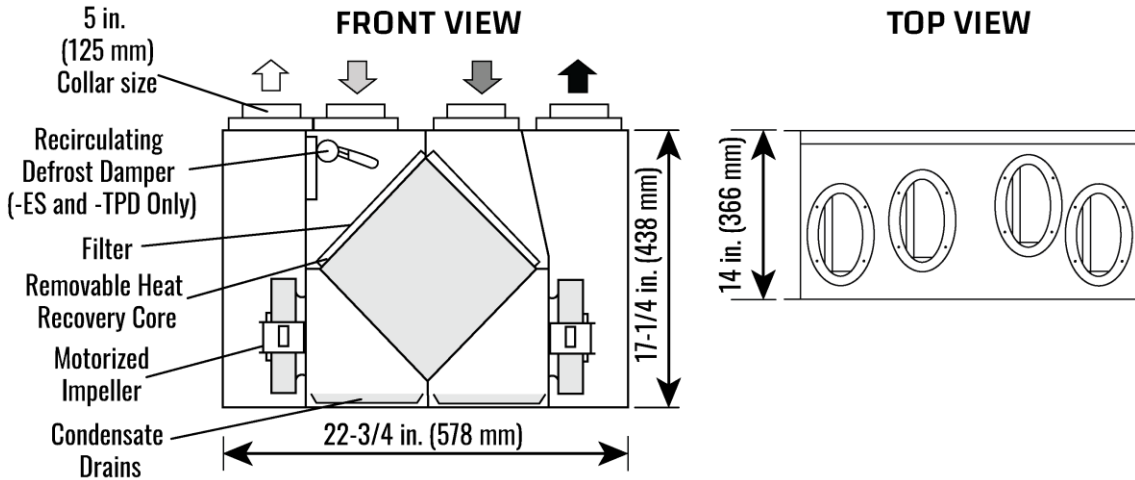

### RNC5-HEX-TPF Dimensions:

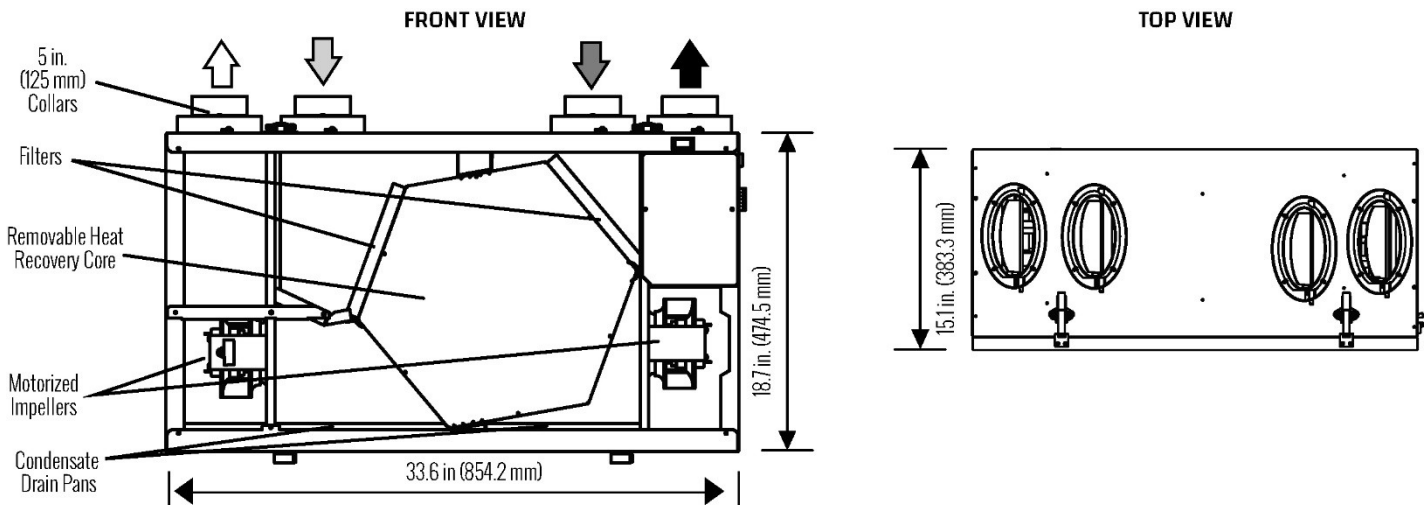

## 22 DIMENSIONAL DRAWINGS

### Airflow:

- ↗ Stale Air to Outside
- ↘ Fresh Air from Outside
- ↖ Stale Air from Inside
- ↙ Fresh Air to Inside

### RNC6-HEX-TPD Dimensions:

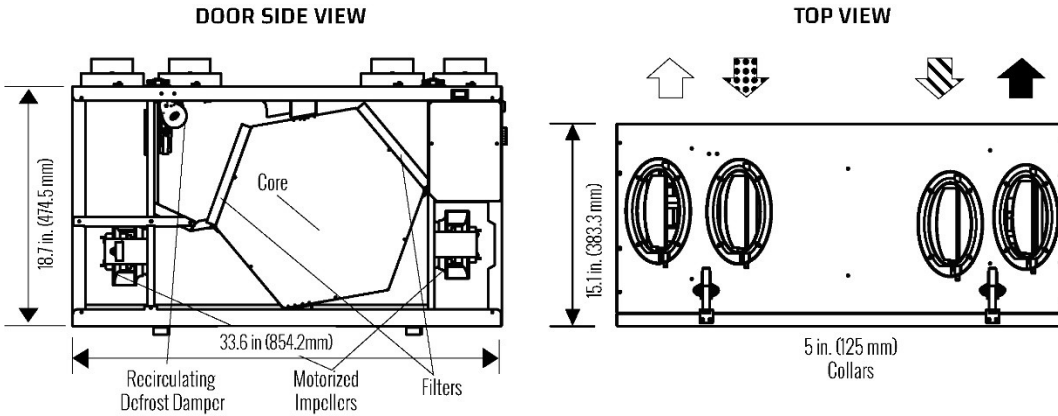

### 155MAX 2019, and RNC155 2019 Dimensions:

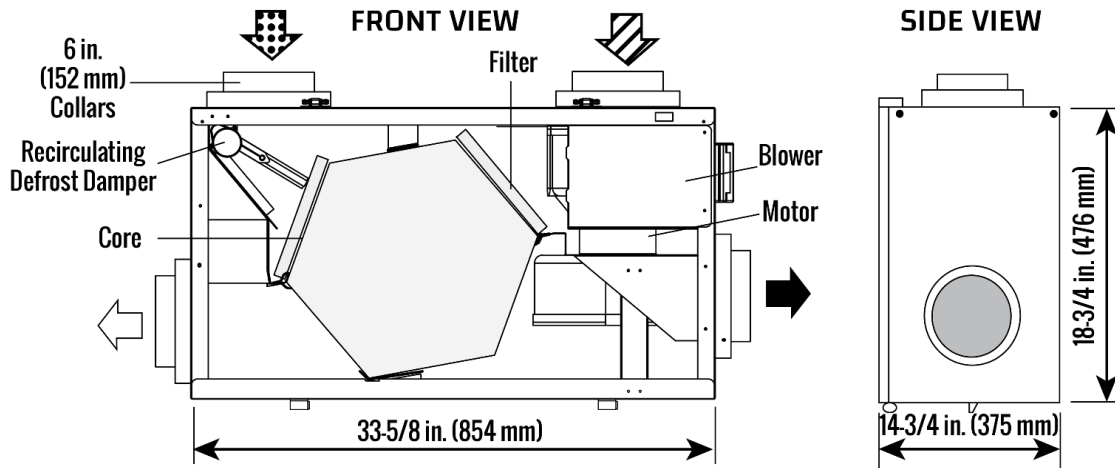

### RNC88 Dimensions:

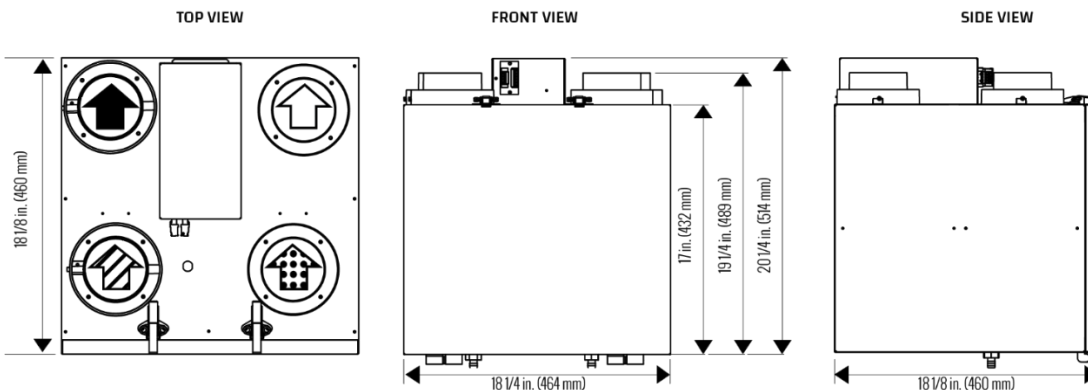

# 22 DIMENSIONAL DRAWINGS

## 205MAX, 267MAX, RNC205 and RNC205 PLUS Dimensions:

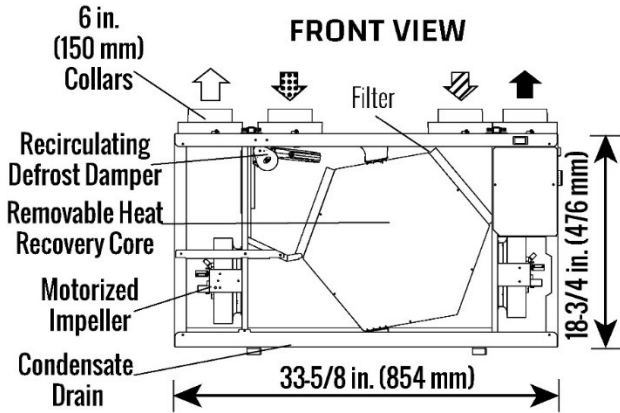

TOP VIEW

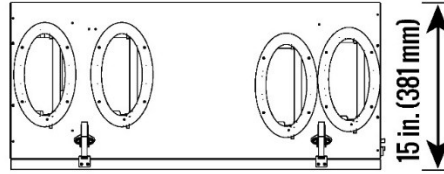

**Airflow:**

- Stale Air to Outside
- Fresh Air from Outside
- Stale Air from Inside
- Fresh Air to Inside

## 195DCS Dimensions:

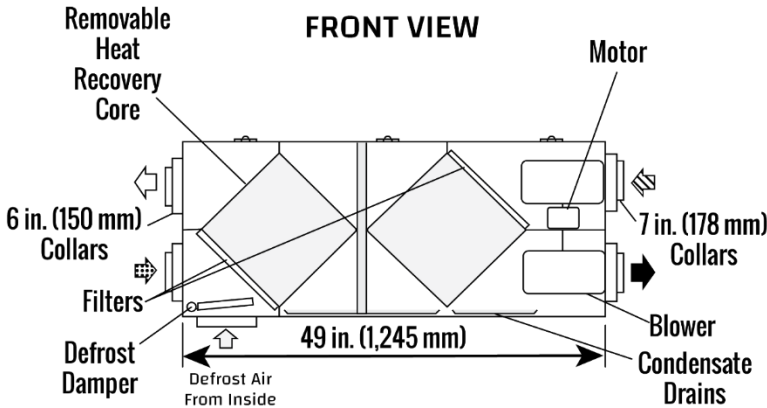

SIDE VIEW

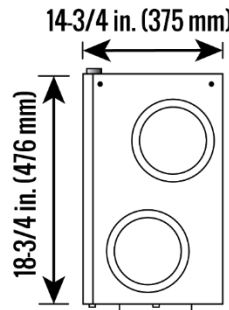

## RNC 200 Dimensions:

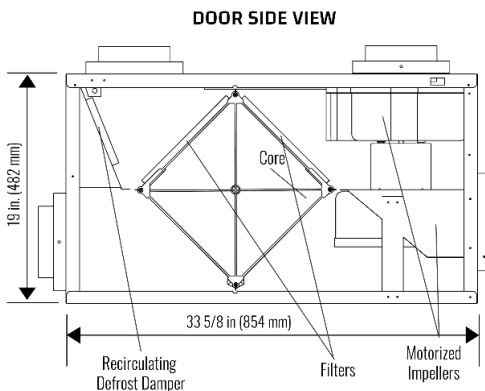

SIDE VIEW

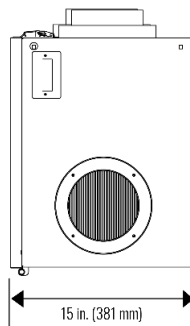

TOP VIEW

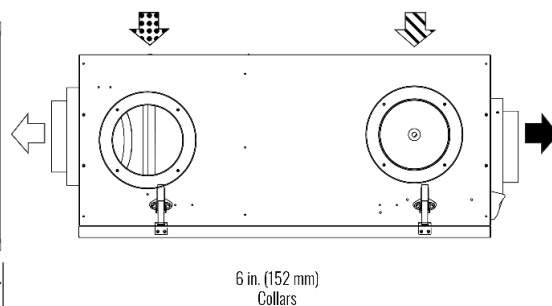

## 23 BALANCING THE AIRFLOWS

Balancing the airflows is critical to ensure that the amount of air coming into the building equals the amount of air exhausted to the outside of the building. If these two airflows are not properly balanced, the following issues may occur:

- A positive or negative pressure in the house
- HRV will not operate at its maximum efficiency
- HRV will not defrost properly.

### Airflow Measuring Gauge:

- A digital manometer is a suitable instrument for the balancing of airflows.

### Airflow Balancing Kit:

- Kit includes a digital manometer, pitot tubes, hose, adapters, and tool bag.



**Airflow Balancing Kit (99-BAL-KIT)**

### Gauge Attachments:

When sampling an airflow, various attachments are available for use on a digital manometer. Consult with your Lifebreath distributor for available options such as a pitot tube, flow measuring station, and an airflow measuring probe. The illustration below shows a digital manometer with a pitot tube attachment. This combination will measure the system air velocity pressure accurately, regardless of the duct size or shape (either round or rectangular).

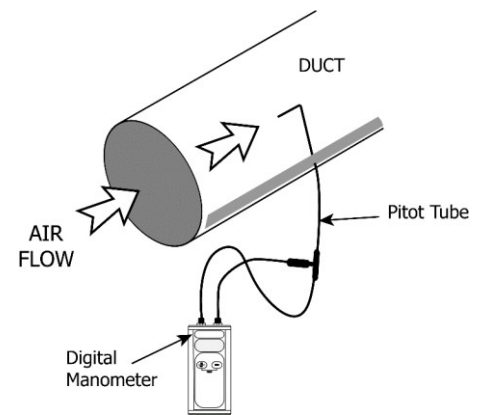

### Balancing Preparation:

Prior to performing the air balancing procedure, perform the following steps:

1. Seal the ductwork.
2. Confirm the installation and proper operation of all the components of the HRV.
3. Fully open the balancing dampers.
4. Turn on all household exhaust devices (range hood, clothes dryer, bathroom fans).
5. Set the HRV at high speed.
6. Prior to balancing the unit, first adjust airflows in the branch lines to specific areas of the house.
7. If the outdoor temperature is below 0°C (32°F), ensure the unit is not running in defrost.
8. If the system is a Simplified or Partially Dedicated installation, operate the furnace/air handler at high speed.



## Attention

- Continuous, excessive, positive pressure may drive moist indoor air into the external walls of the building. Once inside the external walls, moist air may condense (in cold weather) and degrade structural components or cause locks to freeze.
- Continuous, excessive, negative pressure may have several undesirable effects. In some geographic locations, soil gases such as methane and radon gas may be drawn into the home through basement or ground contact areas and may also cause the backdrafting of vented combustion equipment.

## 23 BALANCING THE AIRFLOWS

### Determining the CFM:

After balancing the airflows, calculate the CFM flow rate.

### Example

This example shows how to determine the airflow for a 6 in diameter duct. If the duct velocity pressure reads 0.025 in w.g. on the digital manometer, use the chart that came with the pitot tube to determine a duct velocity of 640 ft/min. for a duct velocity pressure of 0.025 in w.g.

### CFM Calculation

$$\begin{aligned}\text{CFM} &= \text{feet per minute} \times \text{cross section area of duct} \\ &= 640 \times 0.196 \\ &= 125\end{aligned}$$

*Cross section area of some common duct sizes:*

Cross-Section Area	Duct Size
0.087	4 in duct
0.139	5 in duct
0.196	6 in duct
0.267	7 in duct

### Units with Balancing Collars:

Install these units with the dampers fully open and damper down the duct with the higher airflow equal to the lower airflow. All other units require dampers for balancing airflows installed into the "Fresh Air to Building" and "Stale Air from Building" ductwork.

### Hard/Rigid Ducting

- Push and turn with slotted screwdriver. Damper automatically locks when pressure released.

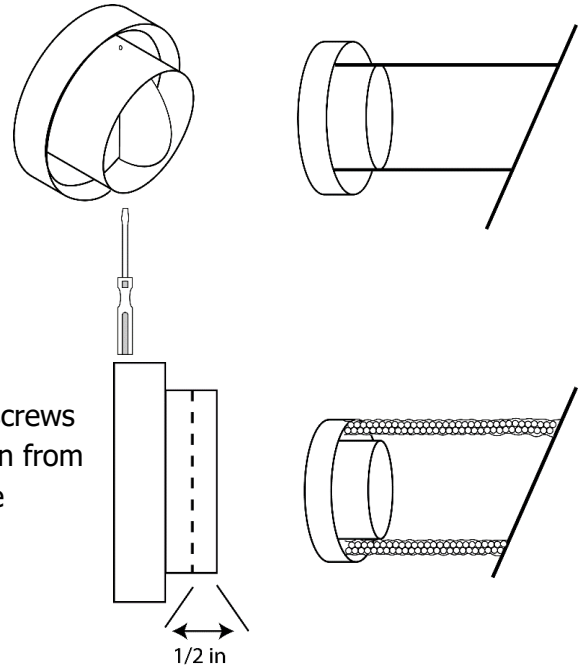

### Insulated flexible ducting

- When connecting ductwork to the collar, take note where screws are located. Screws should be located no further than 1/2 in from outside edge of collar, so as not to impede operation of the damper.



## Attention

- Installations where the HRV is ducted directly to the return of a furnace may require additional dampening on the fresh air to building duct. This is due to the high return static pressures found in some furnace installations.

## 24 BALANCING THE AIRFLOWS – PITOT TUBE

### Figure Callouts:

- (1) 3/16 in. Hole
- (2) Pitot Tube Tip
- (3) Digital Manometer
- (4) Balancing Damper

### Airflow:

- ⇨ Stale Air to Outside
- ⇨ Fresh Air from Outside
- ⇨ Stale Air from Inside
- ⇨ Fresh Air to Inside

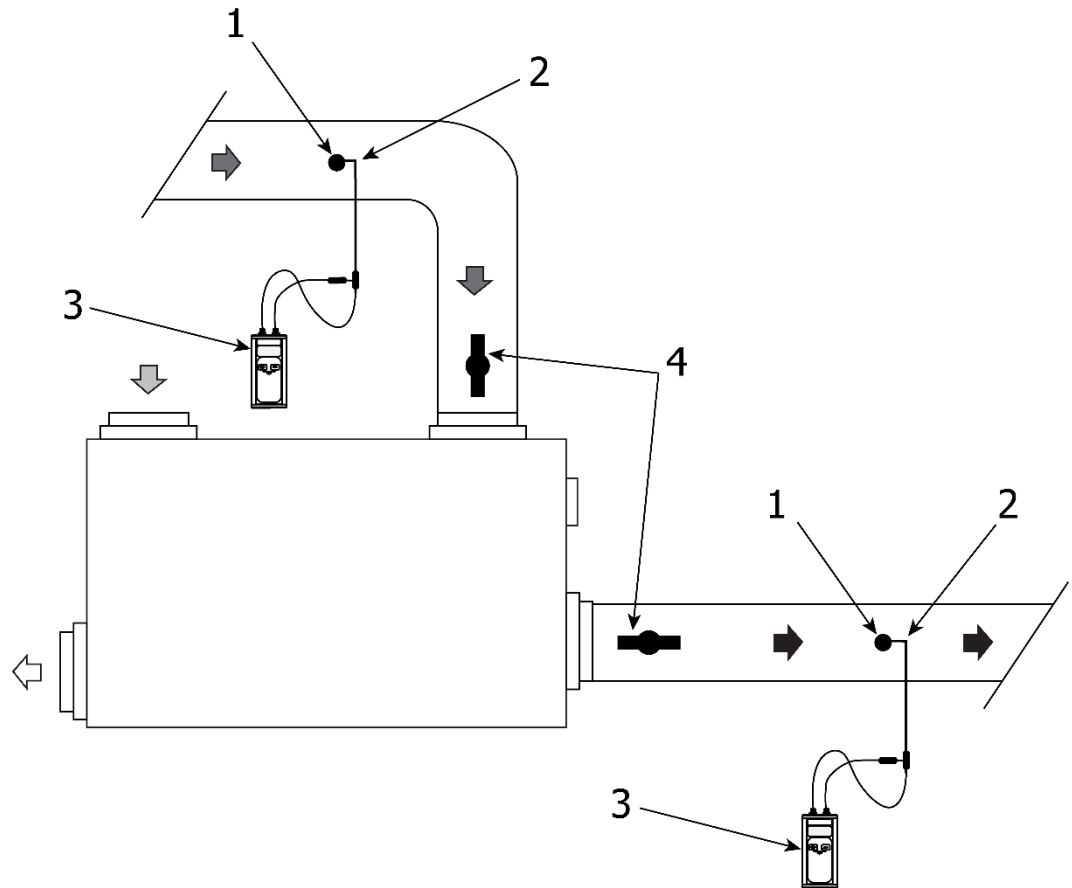

### Steps:

1. Drill a 3/16 in. hole in the duct, ideally 3 ft. downstream and 1 ft. upstream of any elbows or bends in the fresh air and stale air streams.
2. Insert the pitot tube with the tip facing towards the air stream in the "Stale Air from Inside" stream. Move the pitot tube around in the duct (facing toward the airflow) and take an average reading. Record the reading.
3. Repeat Step 2 to measure the "Fresh Air to Inside" stream.
4. Review the readings and damper down the duct with the highest duct velocity pressure. Repeat Steps 2 and 3 until both ducts show identical readings. Upon completion of balancing, seal the holes with foil tape.

## 25 BALANCING THE AIRFLOWS – DOOR PORTS

---

Door balancing ports are designed to be used in the conjunction with a digital manometer to measure the stale and fresh airflows for balancing. Refer to [Door Port Locations](#) for your model to locate the door ports.

1. Prepare the airflow measuring device by connecting the hoses to the low- and high-pressure side of the gauge.
2. Insert the hoses into suitable rubber fittings (comes with 99-BAL-KIT). Use light pressure and rotate until fitting is snug. Do not extend the hose past the rubber fitting.
3. Open the HRV door. Remove the four door port covers by carefully pushing them out from the back side of the door.
4. Close the HRV door. Initiate power and operate the HRV on high speed. Operate the forced air system on high speed (if the HRV is connected to the forced air system).
5. Insert the 2 hoses from the gauge into the exhaust balance ports. Seal the supply balance ports with tape. Record your reading. If you get a negative reading, the hoses need to be reversed.
6. Insert the 2 hoses from the gauge to the supply balance ports. Seal the exhaust balance ports with tape. Record your reading. If you get a negative reading, the hoses need to be reversed.
7. Refer to [Airflow Charts](#) for your model to determine the supply airflow and exhaust airflow rates.
8. Damper down the higher airflow and repeat Steps 5 through 7 as required until both airflows are identical (balanced).
9. Remove the tape and hoses and reinstall the four door port covers.

## 26 DOOR PORT LOCATIONS

### Door Ports

- (1) Exhaust Balance Port High (+)
- (2) Exhaust Balance Port Low (-)
- (3) Supply Balance Port High (+)
- (4) Supply Balance Port Low (-)

### Airflow:

- ☐ Stale Air to Outside
- ▣ Fresh Air from Outside
- ▣ Stale Air from Inside
- ▣ Fresh Air to Inside

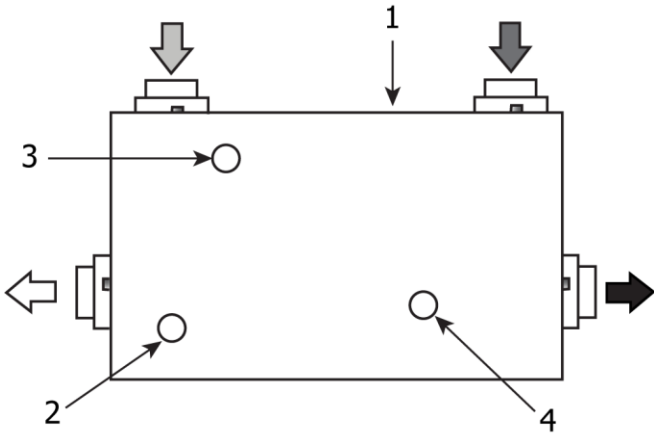

**RNC 155 2019  
MAX 155 2019**

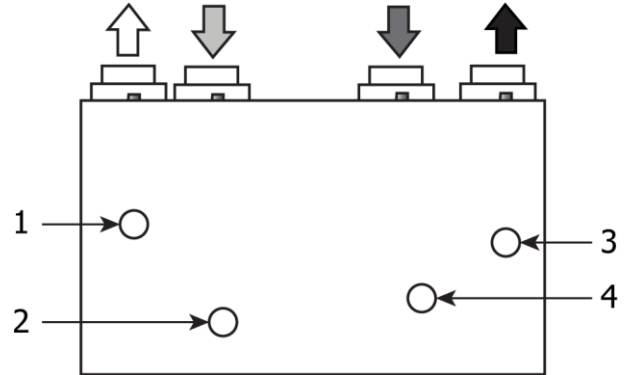

**RNC5-TPD/TPF/ RNC 6ES  
RNC6-HEX-TPD/5-HEX-TPF  
RNC205, RNC205 PLUS, MAX 205  
and MAX 267**

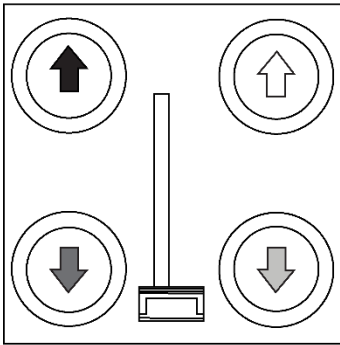

**RNC4-TPD  
RNC4-TPF**

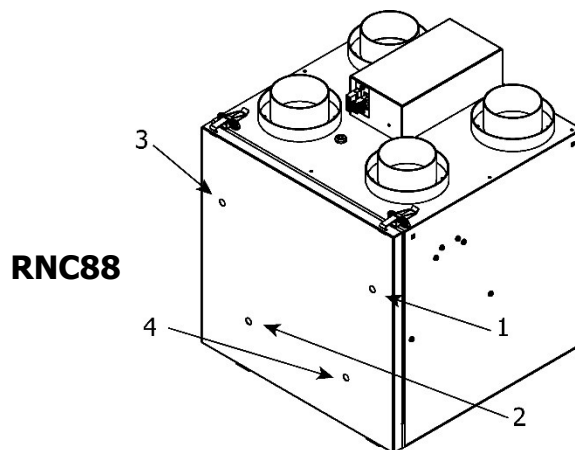
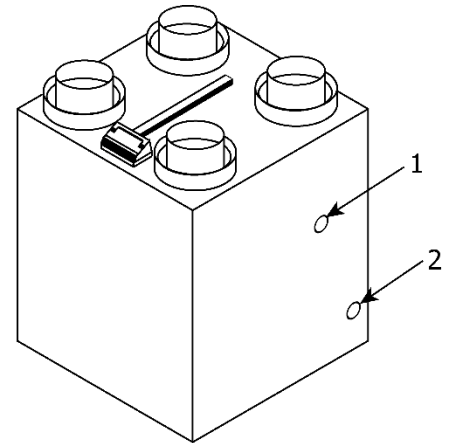
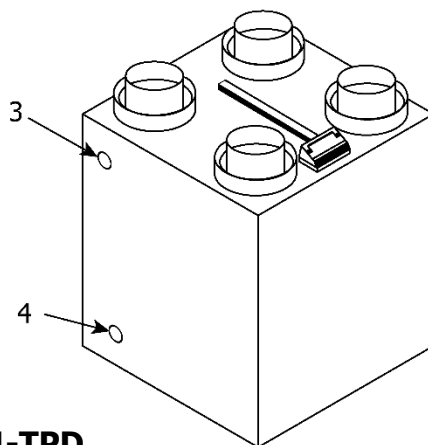

**RNC88**

## 27 AIRFLOW CHARTS (RNC88)

The RNC 88 units have three airflow charts for their installer adjustable high speed settings. Refer to [Installer Selectable High Speed Settings](#) in this manual for instructions on how to adjust the circuit board DIP switches.

Hi 3				Hi 2				Hi 1			
Pressure Drop		Supply Airflow	Exhaust Airflow	Pressure Drop		Supply Airflow	Exhaust Airflow	Pressure Drop		Supply Airflow	Exhaust Airflow
("w.g.)	(Pa)	(cfm)	(cfm)	("w.g.)	(Pa)	(cfm)	(cfm)	("w.g.)	(Pa)	(cfm)	(cfm)
0.010	2	21	25	0.010	2	18	21	0.010	2	18	21
0.015	4	25	29	0.015	4	22	25	0.015	4	22	24
0.020	5	28	32	0.020	5	25	28	0.020	5	25	28
0.025	6	32	35	0.025	6	29	32	0.025	6	29	31
0.030	7	36	38	0.030	7	33	35	0.030	7	33	35
0.035	9	39	41	0.035	9	37	39	0.035	9	37	38
0.040	10	43	45	0.040	10	40	42	0.040	10	41	42
0.045	11	46	48	0.045	11	44	45	0.045	11	45	45
0.050	12	50	51	0.050	12	48	49	0.050	12	48	49
0.055	14	53	54	0.055	14	52	52	0.055	14	52	52
0.060	15	57	58	0.060	15	56	56	0.060	15	56	56
0.065	16	60	61	0.065	16	59	59	0.065	16	60	59
0.070	17	64	64	0.070	17	63	63	0.070	17	64	63
0.075	19	68	67	0.075	19	67	66	0.075	19	68	66
0.080	20	71	71	0.080	20	71	70	0.080	20	71	70
0.085	21	75	74	0.085	21	75	73	0.085	21	75	73
0.090	22	78	77	0.090	22	78	76	0.090	22	79	77
0.095	24	82	80	0.095	24	82	80	0.095	24	83	80
0.100	25	85	84	0.100	25	86	83	0.100	25	87	84
0.105	26	89	87	0.105	26	90	87	0.105	26	91	87
0.110	27	92	90	0.110	27	94	90	0.110	27	95	91
0.115	29	96	93	0.115	29	97	94	0.115	29	98	94
0.120	30	100	97	0.120	30	101	97	0.120	30	102	98
0.125	31	103	100	0.125	31	105	100	0.125	31	106	101
0.130	32	107	103	0.130	32	109	104	0.130	32	110	105
0.135	34	110	106	0.135	34	113	107	0.135	34		108
0.140	35	114	110	0.140	35		111				
0.145	36	117	113								
0.150	37	121	116								
0.155	39		119								

## 28 AIRFLOW CHARTS (RNC4-TPD)

The RNC4-TPD units have three airflow charts for their installer adjustable high speed settings. Refer to [Installer Selectable High Speed Settings](#) in this manual for instructions on how to adjust the circuit board DIP switches.

Hi 3				Hi 2				Hi 1			
Pressure Drop		Supply Airflow	Exhaust Airflow	Pressure Drop		Supply Airflow	Exhaust Airflow	Pressure Drop		Supply Airflow	Exhaust Airflow
("w.g.)	(Pa)	(cfm)	(cfm)	("w.g.)	(Pa)	(cfm)	(cfm)	("w.g.)	(Pa)	(cfm)	(cfm)
0.400	100	-	74	0.330	83	-	73	0.280	70	-	69
0.410	103	-	74	0.340	85	-	72	0.290	73	-	69
0.420	105	-	73	0.350	88	73	72	0.300	75	-	68
0.430	108	-	73	0.360	90	73	71	0.310	78	-	67
0.440	110	-	72	0.370	93	73	70	0.320	80	71	66
0.450	113	-	71	0.380	95	73	69	0.330	83	71	65
0.460	115	75	71	0.390	98	73	69	0.340	85	71	64
0.470	118	75	70	0.400	100	72	68	0.350	88	70	63
0.480	120	75	69	0.410	103	72	67	0.360	90	69	62
0.490	123	74	69	0.420	105	72	66	0.370	93	69	61
0.500	125	74	68	0.430	108	71	65	0.380	95	68	60
0.510	128	74	67	0.440	110	71	64	0.390	98	68	59
0.520	130	74	66	0.450	113	70	63	0.400	100	67	58
0.530	133	73	65	0.460	115	70	62	0.410	103	66	57
0.540	135	73	65	0.470	118	69	62	0.420	105	65	56
0.550	138	73	64	0.480	120	69	61	0.430	108	65	55
0.560	140	72	63	0.490	123	68	60	0.440	110	64	54
0.570	143	72	62	0.500	125	67	58	0.450	113	63	52
0.580	145	71	61	0.510	128	67	57	0.460	115	62	51
0.590	148	70	60	0.520	130	66	56	0.470	118	61	50
0.600	150	69	59	0.530	133	65	55	0.480	120	60	49

Continued next page ►

## 28 AIRFLOW CHARTS (RNC4-TPD)

The RNC4-TPD units have three airflow charts for their installer adjustable high speed settings. Refer to [Installer Selectable High Speed Settings](#) in this manual for instructions on how to adjust the circuit board DIP switches.

Hi 3				Hi 2				Hi 1			
Pressure Drop		Supply Airflow	Exhaust Airflow	Pressure Drop		Supply Airflow	Exhaust Airflow	Pressure Drop		Supply Airflow	Exhaust Airflow
("w.g.)	(Pa)	(cfm)	(cfm)	("w.g.)	(Pa)	(cfm)	(cfm)	("w.g.)	(Pa)	(cfm)	(cfm)
0.610	153	69	58	0.540	135	64	54	0.490	123	59	48
0.620	155	68	57	0.550	138	63	53	0.500	125	58	46
0.630	158	67	56	0.560	140	62	52	0.510	128	57	45
0.640	160	66	54	0.570	143	61	51	0.520	130	56	44
0.650	163	65	53	0.580	145	60	50	0.530	133	55	42
0.660	165	64	52	0.590	148	59	48	0.540	135	54	41
0.670	168	62	51	0.600	150	58	47	0.550	138	53	40
0.680	170	61	50	0.610	153	57	46	0.560	140	52	38
0.690	173	60	48	0.620	155	56	45	0.570	143	51	37
0.700	175	58	47	0.630	158	54	43	0.580	145	49	36
0.710	178	57	46	0.640	160	53	42	0.590	148	48	34
0.720	180	56	44	0.650	163	52	41	0.600	150	47	33
0.730	183	54	43	0.660	165	50	39	0.610	153	45	31
0.740	185	52	41	0.670	168	49	38	0.620	155	44	30
0.750	188	51	40	0.680	170	47	36	0.630	158	43	28
0.760	190	49	39	0.690	173	46	35	0.640	160	41	27
0.770	193	47	37	0.700	175	44	34	0.650	163	40	25
0.780	195	45	36	0.710	178	43	32	0.660	165	38	24
0.790	198	43	34	0.720	180	41	31	0.670	168	37	22
0.800	200	41	32	0.730	183	39	29	0.680	170	35	20
0.810	203	39	31	0.740	185	37	28	0.690	173	34	19

## 29 AIRFLOW CHARTS (RNC6-ES)

The RNC6-ES units have three airflow charts for their installer adjustable high speed settings. Refer to [Installer Selectable High Speed Settings](#) in this manual for instructions on how to adjust the circuit board DIP switches.

Hi 3				Hi 2				Hi 1			
Pressure Drop		Supply Airflow	Exhaust Airflow	Pressure Drop		Supply Airflow	Exhaust Airflow	Pressure Drop		Supply Airflow	Exhaust Airflow
("w.g.)	(Pa)	(cfm)	(cfm)	("w.g.)	(Pa)	(cfm)	(cfm)	("w.g.)	(Pa)	(cfm)	(cfm)
0.70	174	-	158	0.57	142	-	140	0.50	125	-	124
0.71	177	-	155	0.58	145	-	137	0.51	127	-	120
0.72	179	-	152	0.59	147	-	134	0.52	130	-	117
0.73	182	-	149	0.60	150	-	131	0.53	132	-	114
0.74	184	-	146	0.61	152	-	127	0.54	135	-	110
0.75	187	-	143	0.62	154	-	124	0.55	137	-	107
0.76	189	-	140	0.63	157	-	121	0.56	140	-	104
0.77	192	-	137	0.64	159	-	118	0.57	142	-	101
0.78	194	-	134	0.65	162	-	115	0.58	145	-	98
0.79	197	-	131	0.66	164	-	112	0.59	147	-	94
0.80	199	-	128	0.67	167	-	109	0.60	150	126	91
0.81	202	-	125	0.68	169	-	106	0.61	152	121	88
0.82	204	-	122	0.69	172	-	103	0.62	154	116	85
0.83	207	-	119	0.70	174	141	100	0.63	157	111	83
0.84	209	-	116	0.71	177	136	97	0.64	159	107	80
0.85	212	-	113	0.72	179	131	94	0.65	162	102	77
0.86	214	-	110	0.73	182	126	92	0.66	164	98	74
0.87	217	155	107	0.74	184	121	89	0.67	167	93	71
0.88	219	149	104	0.75	187	116	86	0.68	169	89	69
0.89	222	144	101	0.76	189	111	83	0.69	172	85	66
0.90	224	139	98	0.77	192	107	80	0.70	174	81	63
0.91	227	134	95	0.78	194	103	77	0.71	177	78	61

Continued next page ►

## 29 AIRFLOW CHARTS (RNC6-ES)

The RNC6-ES units have three airflow charts for their installer adjustable high speed settings. Refer to [Installer Selectable High Speed Settings](#) in this manual for instructions on how to adjust the circuit board DIP switches.

Hi 3				Hi 2				Hi 1			
Pressure Drop		Supply Airflow	Exhaust Airflow	Pressure Drop		Supply Airflow	Exhaust Airflow	Pressure Drop		Supply Airflow	Exhaust Airflow
("w.g.)	(Pa)	(cfm)	(cfm)	("w.g.)	(Pa)	(cfm)	(cfm)	("w.g.)	(Pa)	(cfm)	(cfm)
0.92	229	129	92	0.79	197	98	75	0.72	179	74	58
0.93	232	125	89	0.80	199	94	72	0.73	182	70	56
0.94	234	120	87	0.81	202	90	69	0.74	184	67	53
0.95	237	115	84	0.82	204	86	66	0.75	187	64	51
0.96	239	111	81	0.83	207	83	64	0.76	189	61	48
0.97	242	106	78	0.84	209	79	61	0.77	192	58	46
0.98	244	102	75	0.85	212	75	58	0.78	194	55	44
0.99	247	98	72	0.86	214	72	56	0.79	197	52	42
1.00	249	94	69	0.87	217	68	53	0.80	199	50	-
1.01	252	90	66	0.88	219	65	51	0.81	202	47	-
1.02	254	86	63	0.89	222	62	48	0.82	204	45	-
1.03	257	82	60	0.90	224	59	45	0.83	207	43	-
1.04	259	78	57	0.91	227	56	43	0.84	209	41	-
1.05	262	75	54	0.92	229	53	40	-	-	-	-
1.06	264	71	51	0.93	232	51	-	-	-	-	-
1.07	267	68	48	0.94	234	48	-	-	-	-	-
1.08	269	64	45	0.95	237	46	-	-	-	-	-
1.09	272	61	42	0.96	239	43	-	-	-	-	-
1.10	274	58	-	0.97	242	41	-	-	-	-	-
1.11	277	55	-	-	-	-	-	-	-	-	-
1.12	279	52	-	-	-	-	-	-	-	-	-
1.13	282	49	-	-	-	-	-	-	-	-	-
1.14	284	46	-	-	-	-	-	-	-	-	-
1.15	287	44	-	-	-	-	-	-	-	-	-
1.16	289	41	-	-	-	-	-	-	-	-	-
1.17	292	39	-	-	-	-	-	-	-	-	-

## 30 AIRFLOW CHARTS (RNC5-TPD/TPF)

The RNC5-TPD and RNC5-TPF units have three airflow charts for their installer adjustable high speed settings. Refer to [Installer Selectable High Speed Settings](#) in this manual for instructions on how to adjust the circuit board DIP switches.

Hi 3				Hi 2				Hi 1			
Pressure Drop		Supply Airflow	Exhaust Airflow	Pressure Drop		Supply Airflow	Exhaust Airflow	Pressure Drop		Supply Airflow	Exhaust Airflow
("w.g.)	(Pa)	(cfm)	(cfm)	("w.g.)	(Pa)	(cfm)	(cfm)	("w.g.)	(Pa)	(cfm)	(cfm)
0.580	145	-	177	0.360	90	-	160	0.280	70	-	140
0.590	148	-	174	0.370	93	-	158	0.290	73	-	138
0.600	150	-	172	0.380	95	-	156	0.300	75	-	135
0.610	153	-	169	0.390	98	-	154	0.310	78	-	133
0.620	155	-	167	0.400	100	-	151	0.320	80	-	131
0.630	158	-	164	0.410	103	-	149	0.330	83	-	129
0.640	160	-	162	0.420	105	-	147	0.340	85	-	126
0.650	163	-	159	0.430	108	-	144	0.350	88	-	124
0.660	165	-	157	0.440	110	155	142	0.360	90	-	122
0.670	168	-	154	0.450	113	153	140	0.370	93	139	120
0.680	170	-	152	0.460	115	151	138	0.380	95	137	117
0.690	173	-	149	0.470	118	149	135	0.390	98	135	115
0.700	175	-	147	0.480	120	147	133	0.400	100	133	113
0.710	178	-	144	0.490	123	145	131	0.410	103	131	111
0.720	180	-	142	0.500	125	144	129	0.420	105	129	108
0.730	183	-	139	0.510	128	142	126	0.430	108	127	106
0.740	185	-	137	0.520	130	140	124	0.440	110	125	104
0.750	188	175	134	0.530	133	138	122	0.450	113	123	102
0.760	190	172	132	0.540	135	136	119	0.460	115	121	99
0.770	193	169	129	0.550	138	134	117	0.470	118	119	97
0.780	195	167	127	0.560	140	132	115	0.480	120	117	95
0.790	198	164	124	0.570	143	130	113	0.490	123	115	93
0.800	201	161	121	0.580	145	129	110	0.500	125	113	90
0.810	203	158	119	0.590	148	127	108	0.510	128	111	88
0.820	206	155	116	0.600	150	125	106	0.520	130	109	86
0.830	208	153	114	0.610	153	123	104	0.530	133	107	84
0.840	211	150	111	0.620	155	121	101	0.540	135	105	81
0.850	213	147	109	0.630	158	119	99	0.550	138	102	79
0.860	216	144	106	0.640	160	117	97	0.560	140	100	77
0.870	218	141	104	0.650	163	115	94	0.570	143	98	75
0.880	221	139	101	0.660	165	114	92	0.580	145	96	72

Continued next page ►

## 30 AIRFLOW CHARTS (RNC5-TPD/TPF)

The RNC5-TPD and RNC5-TPF units have three airflow charts for their installer adjustable high speed settings. Refer to [Installer Selectable High Speed Settings](#) in this manual for instructions on how to adjust the circuit board DIP switches.

Hi 3				Hi 2				Hi 1			
Pressure Drop		Supply Airflow	Exhaust Airflow	Pressure Drop		Supply Airflow	Exhaust Airflow	Pressure Drop		Supply Airflow	Exhaust Airflow
("w.g.)	(Pa)	(cfm)	(cfm)	("w.g.)	(Pa)	(cfm)	(cfm)	("w.g.)	(Pa)	(cfm)	(cfm)
0.890	223	136	99	0.670	168	112	90	-	-	-	-
0.900	226	133	96	0.680	170	110	88	-	-	-	-
0.910	228	130	94	0.690	173	108	85	-	-	-	-
0.920	231	127	91	0.700	175	106	83	-	-	-	-
0.930	233	125	89	0.710	178	104	81	-	-	-	-
0.940	236	122	86	0.720	180	102	79	-	-	-	-
0.950	238	119	84	0.730	183	100	76	-	-	-	-
0.960	241	116	81	0.740	185	99	74	-	-	-	-
0.970	243	113	79	0.750	188	97	72	-	-	-	-
0.980	246	111	76	0.760	190	95	69	-	-	-	-
0.990	248	108	74	0.770	193	93	67	-	-	-	-
1.000	251	105	71	0.780	195	91	65	-	-	-	-
1.010	253	102	69	0.790	198	89	63	-	-	-	-
1.020	256	100	66	0.800	200	87	60	-	-	-	-
1.030	258	97	-	0.810	203	85	58	-	-	-	-
1.040	261	94	-	0.820	205	84	56	-	-	-	-
1.050	263	91	-	0.830	208	82	54	-	-	-	-
1.060	266	88	-	0.840	210	80	51	-	-	-	-
1.070	268	86	-	0.850	213	78	-	-	-	-	-
1.080	271	83	-	0.860	215	76	-	-	-	-	-
1.090	273	80	-	0.870	218	74	-	-	-	-	-
1.100	276	77	-	0.880	220	72	-	-	-	-	-
1.110	278	74	-	0.890	223	70	-	-	-	-	-
-	-	-	-	0.900	225	69	-	-	-	-	-
-	-	-	-	0.910	228	67	-	-	-	-	-
-	-	-	-	0.920	230	65	-	-	-	-	-
-	-	-	-	0.930	233	63	-	-	-	-	-
-	-	-	-	0.940	235	61	-	-	-	-	-
-	-	-	-	0.950	238	59	-	-	-	-	-
-	-	-	-	0.960	240	57	-	-	-	-	-
-	-	-	-	0.970	243	55	-	-	-	-	-
-	-	-	-	0.980	245	54	-	-	-	-	-
-	-	-	-	0.990	248	52	-	-	-	-	-
-	-	-	-	1.000	250	50	-	-	-	-	-

## 31 AIRFLOW CHARTS (RNC6-HEX-TPD/5-HEX-TPF)

The RNC6-HEX-TPD and RNC5-HEX-TPF units have three airflow charts for their installer adjustable high speed settings. Refer to [Installer Selectable High Speed Settings](#) in this manual for instructions on how to adjust the circuit board DIP switches.

Hi 3				Hi 2				Hi 1			
Pressure Drop		Supply Airflow	Exhaust Airflow	Pressure Drop		Supply Airflow	Exhaust Airflow	Pressure Drop		Supply Airflow	Exhaust Airflow
("w.g.)	(Pa)	(cfm)	(cfm)	("w.g.)	(Pa)	(cfm)	(cfm)	("w.g.)	(Pa)	(cfm)	(cfm)
0.200	50	125	135	0.200	50	115	128	0.200	50	104	120
0.210	52	124	135	0.210	52	114	127	0.210	52	103	118
0.220	55	123	134	0.220	55	113	126	0.220	55	102	117
0.230	57	122	133	0.230	57	111	125	0.230	57	101	115
0.240	60	121	133	0.240	60	110	124	0.240	60	99	114
0.250	62	120	132	0.250	62	109	123	0.250	62	98	112
0.260	65	119	131	0.260	65	108	121	0.260	65	97	110
0.270	67	118	131	0.270	67	106	120	0.270	67	95	109
0.280	70	117	130	0.280	70	105	119	0.280	70	94	107
0.290	72	116	129	0.290	72	104	118	0.290	72	93	106
0.300	75	115	128	0.300	75	102	116	0.300	75	92	104
0.310	77	114	127	0.310	77	101	115	0.310	77	90	102
0.320	80	113	126	0.320	80	100	113	0.320	80	89	101
0.330	82	112	125	0.330	82	98	112	0.330	82	87	99
0.340	85	111	124	0.340	85	97	110	0.340	85	86	97
0.350	87	109	123	0.350	87	96	109	0.350	87	85	96
0.360	90	108	122	0.360	90	94	107	0.360	90	83	94
0.370	92	107	121	0.370	92	93	106	0.370	92	82	92
0.380	95	106	119	0.380	95	92	104	0.380	95	80	90
0.390	97	105	118	0.390	97	90	103	0.390	97	79	89
0.400	100	103	117	0.400	100	89	101	0.400	100	78	87
0.410	102	102	115	0.410	102	87	99	0.410	102	76	85
0.420	105	101	114	0.420	105	86	98	0.420	105	75	83
0.430	107	99	112	0.430	107	85	96	0.430	107	73	81
0.440	110	98	111	0.440	110	83	94	0.440	110	72	79
0.450	112	97	109	0.450	112	82	92	0.450	112	70	78
0.460	115	95	108	0.460	115	80	90	0.460	115	69	76
0.470	117	94	106	0.470	117	79	88	0.470	117	67	74
0.480	120	92	104	0.480	120	77	87	0.480	120	65	72
0.490	122	91	103	0.490	122	76	85	0.490	122	64	70
0.500	125	90	101	0.500	125	74	83	0.500	125	62	68
0.510	127	88	99	0.510	127	73	81	0.510	127	61	66
0.520	130	87	97	0.520	130	71	79	0.520	130	59	64

Continued next page ►

### 31 AIRFLOW CHARTS (RNC6-HEX-TPD/5-HEX-TPF)

The RNC6-HEX-TPD and RNC5-HEX-TPF units have three airflow charts for their installer adjustable high speed settings. Refer to [Installer Selectable High Speed Settings](#) in this manual for instructions on how to adjust the circuit board DIP switches.

Hi 3				Hi 2				Hi 1			
Pressure Drop		Supply Airflow	Exhaust Airflow	Pressure Drop		Supply Airflow	Exhaust Airflow	Pressure Drop		Supply Airflow	Exhaust Airflow
("w.g.)	(Pa)	(cfm)	(cfm)	("w.g.)	(Pa)	(cfm)	(cfm)	("w.g.)	(Pa)	(cfm)	(cfm)
0.530	132	85	95	0.530	132	70	76	0.530	132	57	62
0.540	135	84	93	0.540	135	68	74	0.540	135	56	60
0.550	137	82	91	0.550	137	66	72	0.550	137	54	58
0.560	139	80	89	0.560	139	65	70	0.560	139	52	56
0.570	142	79	87	0.570	142	63	68	0.570	142	51	54
0.580	144	77	85	0.580	144	62	66	0.580	144	49	52
0.590	147	76	83	0.590	147	60	63	0.590	147	47	50
0.600	149	74	81	0.600	149	58	61	0.600	149	46	47
0.610	152	72	78	0.610	152	57	59	0.610	152	44	45
0.620	154	71	76	0.620	154	55	56	0.620	154	42	43
0.630	157	69	74	0.630	157	54	54	0.630	157	40	41
0.640	159	67	71	0.640	159	52	51	0.640	159	39	39
0.650	162	65	69	0.650	162	50	49	0.650	162	37	37
0.660	164	64	66	0.660	164	49	47	0.660	164	35	34
0.670	167	62	64	0.670	167	47	44	0.670	167	33	32
0.680	169	60	61	0.680	169	45	41	0.680	169	31	30
0.690	172	58	59	0.690	172	43	39	0.690	172	30	-
0.700	174	56	56	0.700	174	42	36	0.700	174	-	-
0.710	177	55	53	0.710	177	40	34	0.710	177	-	-
0.720	179	53	50	0.720	179	38	31	0.720	179	-	-
0.730	182	51	48	0.730	182	37	-	0.730	182	-	-
0.740	184	49	45	0.740	184	35	-	0.740	184	-	-
0.750	187	47	42	0.750	187	33	-	0.750	187	-	-
0.760	189	45	39	0.760	189	31	-	0.760	189	-	-
0.770	192	43	36	0.770	192	-	-	0.770	192	-	-
0.780	194	41	33	0.780	194	-	-	0.780	194	-	-
0.790	197	39	30	0.790	197	-	-	0.790	197	-	-
0.800	199	37	-	0.800	199	-	-	0.800	199	-	-
0.810	202	35	-	0.810	202	-	-	0.810	202	-	-
0.820	204	33	-	0.820	204	-	-	0.820	204	-	-

## 32 AIRFLOW CHARTS (RNC155 2019)

The RNC155 2019 units have three airflow charts for their installer adjustable high speed settings. Refer to [Installer Selectable High Speed Settings](#) in this manual for instructions on how to adjust the circuit board DIP switches.

Hi 3				Hi 2				Hi 1			
Pressure Drop		Supply Airflow	Exhaust Airflow	Pressure Drop		Supply Airflow	Exhaust Airflow	Pressure Drop		Supply Airflow	Exhaust Airflow
("w.g.)	(Pa)	(cfm)	(cfm)	("w.g.)	(Pa)	(cfm)	(cfm)	("w.g.)	(Pa)	(cfm)	(cfm)
0.000	0	-	40	0.000	0	-	35	0.000	0	-	39
0.005	1	-	45	0.005	1	-	40	0.005	1	-	44
0.010	3	-	50	0.010	3	-	44	0.010	3	-	48
0.015	4	-	54	0.015	4	-	49	0.015	4	-	53
0.020	5	-	59	0.020	5	-	54	0.020	5	-	58
0.025	6	-	63	0.025	6	-	59	0.025	6	-	62
0.030	8	-	68	0.030	8	35	63	0.030	8	-	67
0.035	9	-	72	0.035	9	38	68	0.035	9	-	71
0.040	10	-	76	0.040	10	41	72	0.040	10	-	76
0.045	11	-	81	0.045	11	43	77	0.045	11	38	81
0.050	13	39	85	0.050	13	46	81	0.050	13	42	85
0.055	14	43	89	0.055	14	49	85	0.055	14	45	90
0.060	15	46	93	0.060	15	52	90	0.060	15	49	94
0.065	16	49	97	0.065	16	54	94	0.065	16	52	99
0.070	18	53	101	0.070	18	57	98	0.070	18	55	104
0.075	19	56	105	0.075	19	60	102	0.075	19	58	108
0.080	20	59	109	0.080	20	62	106	0.080	20	61	113
0.085	21	62	113	0.085	21	65	110	0.085	21	64	117
0.090	23	65	117	0.090	23	67	114	0.090	23	67	122
0.095	24	68	120	0.095	24	70	118	0.095	24	70	127
0.100	25	71	124	0.100	25	73	122	0.100	25	73	131
0.105	26	74	128	0.105	26	75	126	0.105	26	76	136
0.110	28	76	131	0.110	28	78	129	0.110	28	79	140
0.115	29	79	135	0.115	29	80	133	0.115	29	82	145
0.120	30	81	138	0.120	30	83	137	0.120	30	84	149
0.125	31	84	141	0.125	31	85	140	0.125	31	87	154
0.130	33	86	145	0.130	33	88	144	0.130	33	89	158
0.135	34	89	148	0.135	34	90	147	0.135	34	92	163
0.140	35	91	151	0.140	35	93	150	0.140	35	94	167
0.145	36	93	154	0.145	36	95	154	0.145	36	97	172
0.150	38	96	157	0.150	38	97	157	0.150	38	99	176
0.155	39	98	160	0.155	39	100	160	0.155	39	102	181
0.160	40	100	163	0.160	40	102	163	0.160	40	104	-

Continued next page ►

## 32 AIRFLOW CHARTS (RNC155 2019)

The RNC155 2019 units have three airflow charts for their installer adjustable high speed settings. Refer to [Installer Selectable High Speed Settings](#) in this manual for instructions on how to adjust the circuit board DIP switches.

Hi 3				Hi 2				Hi 1			
Pressure Drop		Supply Airflow	Exhaust Airflow	Pressure Drop		Supply Airflow	Exhaust Airflow	Pressure Drop		Supply Airflow	Exhaust Airflow
("w.g.)	(Pa)	(cfm)	(cfm)	("w.g.)	(Pa)	(cfm)	(cfm)	("w.g.)	(Pa)	(cfm)	(cfm)
0.165	41	102	166	0.165	41	104	166	0.165	41	107	-
0.170	43	104	169	0.170	43	107	169	0.170	43	109	-
0.175	44	106	172	0.175	44	109	172	0.175	44	111	-
0.180	45	108	174	0.180	45	111	175	0.180	45	113	-
0.185	46	110	177	0.185	46	113	178	0.185	46	116	-
0.190	48	112	180	0.190	48	116	181	0.190	48	118	-
0.195	49	114	182	0.195	49	118	184	0.195	49	120	-
0.200	50	116	185	0.200	50	120	186	0.200	50	123	-
0.165	41	102	166	0.165	41	104	166	0.165	41	107	-
0.170	43	104	169	0.170	43	107	169	0.170	43	109	-
0.175	44	106	172	0.175	44	109	172	0.175	44	111	-
0.180	45	108	174	0.180	45	111	175	0.180	45	113	-
0.185	46	110	177	0.185	46	113	178	0.185	46	116	-
0.190	48	112	180	0.190	48	116	181	0.190	48	118	-
0.195	49	114	182	0.195	49	118	184	0.195	49	120	-
0.200	50	116	185	0.200	50	120	186	0.200	50	123	-
0.205	51	118	187	0.205	51	122	189	0.205	51	125	-
0.210	53	120	189	0.210	53	124	192	0.210	53	127	-
0.215	54	122	192	0.215	54	127	-	0.215	54	129	-
0.220	55	123	194	0.220	55	129	-	0.220	55	132	-
0.225	56	125	196	0.225	56	131	-	0.225	56	134	-
0.230	58	127	198	0.230	58	133	-	0.230	58	136	-
0.235	59	129	200	0.235	59	135	-	0.235	59	138	-
0.240	60	131	202	0.240	60	137	-	0.240	60	141	-
0.245	61	132	-	0.245	61	139	-	0.245	61	143	-
0.250	63	134	-	0.250	63	141	-	0.250	63	145	-
0.255	64	136	-	0.255	64	143	-	0.255	64	148	-
0.260	65	138	-	0.260	65	145	-	0.260	65	150	-
0.265	66	139	-	0.265	66	147	-	0.265	66	152	-
0.270	68	141	-	0.270	68	149	-	0.270	68	155	-
0.275	69	143	-	0.275	69	151	-	0.275	69	157	-
0.280	70	145	-	0.280	70	153	-	0.280	70	160	-
0.285	71	146	-	0.285	71	154	-	0.285	71	162	-

Continued next page ►

## 32 AIRFLOW CHARTS (RNC155 2019)

The RNC155 2019 units have three airflow charts for their installer adjustable high speed settings. Refer to [Installer Selectable High Speed Settings](#) in this manual for instructions on how to adjust the circuit board DIP switches.

Hi 3				Hi 2				Hi 1			
Pressure Drop		Supply Airflow	Exhaust Airflow	Pressure Drop		Supply Airflow	Exhaust Airflow	Pressure Drop		Supply Airflow	Exhaust Airflow
("w.g.)	(Pa)	(cfm)	(cfm)	("w.g.)	(Pa)	(cfm)	(cfm)	("w.g.)	(Pa)	(cfm)	(cfm)
0.290	73	148	-	0.290	73	156	-	0.290	73	165	-
0.295	74	150	-	0.295	74	158	-	0.295	74	167	-
0.300	75	152	-	0.300	75	160	-	0.300	75	170	-
0.305	76	154	-	0.305	76	162	-	0.305	76	173	-
0.310	78	156	-	0.310	78	163	-	0.310	78	176	-
0.315	79	158	-	0.315	79	165	-	0.315	79	178	-
0.320	80	159	-	0.320	80	167	-	0.320	80	181	-
0.325	81	161	-	0.325	81	169	-				
0.330	83	163	-	0.330	83	170	-				
0.335	84	165	-	0.335	84	172	-				
0.340	85	167	-	0.340	85	174	-				
0.345	86	170	-	0.345	86	175	-				
0.350	88	172	-	0.350	88	177	-				
0.355	89	174	-	0.355	89	179	-				
0.360	90	176	-	0.360	90	180	-				
0.365	91	178	-	0.365	91	182	-				
0.370	93	181	-	0.370	93	183	-				
0.375	94	183	-	0.375	94	185	-				
0.380	95	185	-	0.380	95	186	-				
0.385	96	188	-	0.385	96	188	-				
0.390	98	190	-	0.390	98	189	-				
0.395	99	193	-	0.395	99	191	-				
0.400	100	196	-	0.400	100	192	-				
0.405	101	198	-								
0.410	103	201	-								

### 33 AIRFLOW CHARTS (RNC200)

Door port balancing on the RNC200 can be achieved by using the following chart.  
Balance this unit on its factory circuit board DIP switch setting (Hi 3)

<b>RNC200</b>			
<b>Reading from Manometer</b>		<b>Airflow Numbers</b>	
<b>Pressure Drop</b>		<b>Supply Airflow</b>	<b>Exhaust Airflow</b>
("w.g.)	(Pa)	(cfm)	(cfm)
0.100	24.9	98	91
0.110	27.4	102	96
0.120	29.9	107	101
0.130	32.4	111	107
0.140	34.9	115	112
0.150	37.4	120	117
0.160	39.9	124	122
0.170	42.4	128	127
0.180	44.9	133	132
0.190	47.3	137	137
0.200	49.8	141	142
0.210	52.3	145	147
0.220	54.8	149	152
0.230	57.3	153	156
0.240	59.8	157	161
0.250	62.3	161	166
0.260	64.8	165	171
0.270	67.3	169	175
0.280	69.8	173	180
0.290	72.3	177	184
0.300	74.8	181	189
0.310	77.2	185	193
0.320	79.7	189	198
0.330	82.2	192	202
0.340	84.7	196	207
0.350	87.2	200	211
0.360	89.7	203	215

## 34 AIRFLOW CHARTS (RNC205)

The RNC205 units have three airflow charts for their installer adjustable high speed settings. Refer to [Installer Selectable High Speed Settings](#) in this manual for instructions on how to adjust the circuit board DIP switches.

Hi 3				Hi 2				Hi 1			
Pressure Drop		Supply Airflow	Exhaust Airflow	Pressure Drop		Supply Airflow	Exhaust Airflow	Pressure Drop		Supply Airflow	Exhaust Airflow
("w.g.)	(Pa)	(cfm)	(cfm)	("w.g.)	(Pa)	(cfm)	(cfm)	("w.g.)	(Pa)	(cfm)	(cfm)
0.65	162	210	-	0.47	117	177	-	0.40	100	153	-
0.66	164	208	-	0.48	120	175	-	0.41	102	150	-
0.67	167	206	-	0.49	122	172	-	0.42	105	147	-
0.68	169	204	-	0.50	125	169	-	0.43	107	144	-
0.69	172	201	204	0.51	127	167	-	0.44	110	141	-
0.70	174	199	202	0.52	130	164	177	0.45	112	138	152
0.71	177	197	200	0.53	132	161	174	0.46	115	136	148
0.72	179	194	197	0.54	135	159	171	0.47	117	133	145
0.73	182	192	195	0.55	137	156	168	0.48	120	130	141
0.74	184	190	193	0.56	140	154	165	0.49	122	128	138
0.75	187	188	191	0.57	142	151	162	0.50	125	125	135
0.76	189	185	188	0.58	145	149	159	0.51	127	123	131
0.77	192	183	186	0.59	147	146	156	0.52	130	120	128
0.78	194	181	184	0.60	150	144	153	0.53	132	117	125
0.79	197	179	182	0.61	152	141	150	0.54	135	115	122
0.80	199	176	179	0.62	154	139	147	0.55	137	112	119
0.81	202	174	177	0.63	157	137	144	0.56	140	110	116
0.82	204	172	175	0.64	159	134	141	0.57	142	108	113
0.83	207	170	173	0.65	162	132	138	0.58	145	105	110
0.84	209	167	171	0.66	164	129	136	0.59	147	103	107
0.85	212	165	168	0.67	167	127	133	0.60	150	100	105
0.86	214	163	166	0.68	169	125	130	0.61	152	98	102
0.87	217	160	164	0.69	172	122	128	0.62	154	96	99
0.88	219	158	162	0.70	174	120	125	0.63	157	94	97
0.89	222	156	159	0.71	177	118	122	0.64	159	91	94
0.90	224	154	157	0.72	179	116	120	0.65	162	89	92
0.91	227	151	155	0.73	182	113	117	0.66	164	87	89
0.92	229	149	153	0.74	184	111	115	0.67	167	85	87
0.93	232	147	150	0.75	187	109	112	0.68	169	83	85
0.94	234	145	148	0.76	189	107	110	0.69	172	81	82
0.95	237	142	146	0.77	192	105	108	0.70	174	79	80
0.96	239	140	144	0.78	194	102	105	0.71	177	77	78
0.97	242	138	142	0.79	197	100	103	0.72	179	75	76
0.98	244	136	139	0.80	199	98	101	0.73	182	73	74
0.99	247	133	137	0.81	202	96	98	0.74	184	71	72
1.00	249	131	135	0.82	204	94	96	0.75	187	69	70
1.01	252	129	133	0.83	207	92	94	0.76	189	67	68
1.02	254	126	130	0.84	209	90	92	0.77	192	65	67

Continued next page ►

## 34 AIRFLOW CHARTS (RNC205)

The RNC205 units have three airflow charts for their installer adjustable high speed settings. Refer to [Installer Selectable High Speed Settings](#) in this manual for instructions on how to adjust the circuit board DIP switches.

Hi 3				Hi 2				Hi 1			
Pressure Drop		Supply Airflow	Exhaust Airflow	Pressure Drop		Supply Airflow	Exhaust Airflow	Pressure Drop		Supply Airflow	Exhaust Airflow
("w.g.)	(Pa)	(cfm)	(cfm)	("w.g.)	(Pa)	(cfm)	(cfm)	("w.g.)	(Pa)	(cfm)	(cfm)
1.03	257	124	128	0.85	212	88	90	0.78	194	63	65
1.04	259	122	126	0.86	214	86	88	0.79	197	61	63
1.05	262	120	124	0.87	217	84	86	0.80	199	60	62
1.06	264	117	121	0.88	219	82	83	0.81	202	58	60
1.07	267	115	119	0.89	222	80	82	0.82	204	56	59
1.08	269	113	117	0.90	224	78	80	0.83	207	54	57
1.09	272	111	115	0.91	227	76	78	0.84	209	53	56
1.10	274	108	113	0.92	229	74	76	0.85	212	51	55
1.11	277	106	110	0.93	232	72	74	0.86	214	49	53
1.12	279	104	108	0.94	234	70	72	0.87	217	48	52
1.13	282	102	106	0.95	237	69	70	0.88	219	46	51
1.14	284	99	104	0.96	239	67	69	0.89	222	45	50
1.15	287	97	101	0.97	242	65	67	0.9	224	43	49
1.16	289	95	99	0.98	244	63	65	0.91	227	42	48
1.17	292	92	97	0.99	247	61	63	0.92	229	40	47
1.18	294	90	95	1.00	249	59	62	0.93	232	-	46
1.19	297	88	92	1.01	252	58	60	0.94	234	-	45
1.20	299	86	90	1.02	254	56	59	0.95	237	-	45
1.21	302	83	88	1.03	257	54	57	0.96	239	-	44
1.22	304	81	86	1.04	259	53	56	0.97	242	-	43
1.23	306	79	84	1.05	262	51	54	0.98	244	-	43
1.24	309	77	81	1.06	264	49	53	0.99	247	-	42
1.25	311	74	79	1.07	267	48	51	1.00	249	-	42
1.26	314	72	77	1.08	269	46	50	1.01	252	-	41
1.27	316	70	75	1.09	272	44	49	1.02	254	-	41
1.28	319	68	72	1.10	274	43	47	1.03	257	-	41
1.29	321	65	70	1.11	277	41	46	1.04	259	-	41
1.30	324	63	68	1.12	279	40	45	1.05	262	-	40
1.31	326	61	66	1.13	282	-	44	-	-	-	-
1.32	329	58	63	1.14	284	-	43	-	-	-	-
1.33	331	56	61	1.15	287	-	41	-	-	-	-
1.34	334	54	59	1.16	289	-	40	-	-	-	-
1.35	336	52	57	-	-	-	-	-	-	-	-
1.36	339	49	54	-	-	-	-	-	-	-	-
1.37	341	47	52	-	-	-	-	-	-	-	-
1.38	344	45	50	-	-	-	-	-	-	-	-
1.39	346	43	48	-	-	-	-	-	-	-	-
1.40	349	40	46	-	-	-	-	-	-	-	-
1.41	351	-	43	-	-	-	-	-	-	-	-
1.42	354	-	41	-	-	-	-	-	-	-	-

## 35 AIRFLOW CHARTS (RNC205 PLUS)

The RNC205 PLUS units have three airflow charts for their installer adjustable high speed settings. Refer to [Installer Selectable High Speed Settings](#) in this manual for instructions on how to adjust the circuit board DIP switches.

Hi 3				Hi 2				Hi 1			
Pressure Drop		Supply Airflow	Exhaust Airflow	Pressure Drop		Supply Airflow	Exhaust Airflow	Pressure Drop		Supply Airflow	Exhaust Airflow
("w.g.)	(Pa)	(cfm)	(cfm)	("w.g.)	(Pa)	(cfm)	(cfm)	("w.g.)	(Pa)	(cfm)	(cfm)
0.65	162	200	-	0.51	127	175	-	0.37	92	144	-
0.66	164	199	-	0.52	129	173	-	0.38	95	143	-
0.67	167	197	-	0.53	132	171	-	0.39	97	141	-
0.68	169	195	-	0.54	134	169	-	0.40	100	139	-
0.69	172	193	-	0.55	137	167	-	0.41	102	137	-
0.70	174	191	-	0.56	139	165	-	0.42	105	135	-
0.71	177	189	-	0.57	142	163	-	0.43	107	133	-
0.72	179	187	-	0.58	144	161	-	0.44	109	132	-
0.73	182	185	-	0.59	147	159	-	0.45	112	130	-
0.74	184	183	-	0.60	149	157	-	0.46	114	128	143
0.75	187	181	-	0.61	152	155	-	0.47	117	126	141
0.76	189	179	-	0.62	154	154	174	0.48	119	124	140
0.77	192	177	-	0.63	157	152	172	0.49	122	123	138
0.78	194	175	195	0.64	159	150	170	0.50	124	121	136
0.79	197	173	193	0.65	162	148	168	0.51	127	119	134
0.80	199	171	191	0.66	164	146	166	0.52	129	117	132
0.81	202	169	189	0.67	167	144	164	0.53	132	115	130
0.82	204	167	187	0.68	169	142	162	0.54	134	113	128
0.83	207	165	185	0.69	172	140	160	0.55	137	112	127
0.84	209	163	183	0.70	174	138	158	0.56	139	110	125
0.85	212	161	181	0.71	177	136	156	0.57	142	108	123
0.86	214	159	179	0.72	179	134	154	0.58	144	106	121
0.87	216	157	177	0.73	182	132	152	0.59	147	104	119
0.88	219	155	174	0.74	184	130	149	0.60	149	103	117
0.89	221	154	172	0.75	187	128	147	0.61	152	101	116
0.90	224	152	170	0.76	189	126	145	0.62	154	99	114
0.91	226	150	168	0.77	192	124	143	0.63	157	97	112
0.92	229	148	166	0.78	194	122	141	0.64	159	95	110
0.93	231	146	164	0.79	197	120	139	0.65	162	94	108
0.94	234	144	162	0.80	199	118	137	0.66	164	92	106
0.95	236	142	160	0.81	202	116	135	0.67	167	90	105
0.96	239	140	158	0.82	204	114	133	0.68	169	88	103
0.97	241	138	156	0.83	207	112	131	0.69	172	86	101
0.98	244	136	154	0.84	209	111	129	0.70	174	84	99
0.99	246	134	152	0.85	212	109	127	0.71	177	83	97

Continued next page ►

## 35 AIRFLOW CHARTS (RNC205 PLUS)

The RNC205 PLUS units have three airflow charts for their installer adjustable high speed settings. Refer to [Installer Selectable High Speed Settings](#) in this manual for instructions on how to adjust the circuit board DIP switches.

Hi 3				Hi 2				Hi 1			
Pressure Drop		Supply Airflow	Exhaust Airflow	Pressure Drop		Supply Airflow	Exhaust Airflow	Pressure Drop		Supply Airflow	Exhaust Airflow
("w.g.)	(Pa)	(cfm)	(cfm)	("w.g.)	(Pa)	(cfm)	(cfm)	("w.g.)	(Pa)	(cfm)	(cfm)
1.00	249	132	150	0.86	214	107	125	0.72	179	81	95
1.01	251	130	148	0.87	216	105	123	0.73	182	79	93
1.02	254	128	145	0.88	219	103	121	0.74	184	77	92
1.03	256	126	143	0.89	221	101	119	0.75	187	75	90
1.04	259	124	141	0.90	224	99	117	0.76	189	74	88
1.05	261	122	139	0.91	226	97	115	0.77	192	72	86
1.06	264	120	137	0.92	229	95	113	0.78	194	70	84
1.07	266	118	135	0.93	231	93	111	0.79	197	68	82
1.08	269	116	133	0.94	234	91	109	0.80	199	66	81
1.09	271	114	131	0.95	236	89	107	0.81	202	64	79
1.10	274	112	129	0.96	239	87	105	0.82	204	63	77
1.11	276	110	127	0.97	241	85	103	0.83	207	61	75
1.12	279	109	125	0.98	244	83	100	0.84	209	59	73
1.13	281	107	123	0.99	246	81	98	0.85	212	57	71
1.14	284	105	121	1.00	249	79	96	0.86	214	55	70
1.15	286	103	119	1.01	251	77	94	0.87	216	54	68
1.16	289	101	117	1.02	254	75	92	0.88	219	52	66
1.17	291	99	114	1.03	256	73	90	0.89	221	50	64
1.18	294	97	112	1.04	259	71	88	0.90	224	48	62
1.19	296	95	110	1.05	261	69	86	0.91	226	46	60
1.20	299	93	108	1.06	264	68	84	0.92	229	44	58
1.21	301	91	106	1.07	266	66	82	0.93	231	43	57
1.22	304	89	104	1.08	269	64	80	0.94	234	41	55
1.23	306	87	102	1.09	271	62	78	0.95	236	-	53
1.24	309	85	100	1.10	274	60	76	0.96	239	-	51
1.25	311	83	98	1.11	276	58	74	0.97	241	-	49
1.26	314	81	96	1.12	279	56	72	0.98	244	-	47
1.27	316	79	94	1.13	281	54	70	0.99	246	-	46
1.28	319	77	92	1.14	284	52	68	1.00	249	-	44
1.29	321	75	90	1.15	286	50	66	1.01	251	-	42
1.30	323	73	88	1.16	289	48	64	1.02	254	-	40
1.31	326	71	85	1.17	291	46	62	-	-	-	-
1.32	328	69	83	1.18	294	44	60	-	-	-	-
1.33	331	67	81	1.19	296	42	58	-	-	-	-
1.34	333	65	79	1.20	299	40	56	-	-	-	-

Continued next page ►

## 35 AIRFLOW CHARTS (RNC205 PLUS)

The RNC205 PLUS units have three airflow charts for their installer adjustable high speed settings. Refer to [Installer Selectable High Speed Settings](#) in this manual for instructions on how to adjust the circuit board DIP switches.

Hi 3				Hi 2				Hi 1			
Pressure Drop		Supply Airflow	Exhaust Airflow	Pressure Drop		Supply Airflow	Exhaust Airflow	Pressure Drop		Supply Airflow	Exhaust Airflow
("w.g.)	(Pa)	(cfm)	(cfm)	("w.g.)	(Pa)	(cfm)	(cfm)	("w.g.)	(Pa)	(cfm)	(cfm)
1.35	336	64	77	1.21	301	-	54	-	-	-	-
1.36	338	62	75	1.22	304	-	51	-	-	-	-
1.37	341	60	73	1.22	304	-	51	-	-	-	-
1.38	343	58	71	1.23	306	-	49	-	-	-	-
1.39	346	56	69	1.24	309	-	47	-	-	-	-
1.40	348	54	67	1.25	311	-	45	-	-	-	-
1.41	351	52	65	1.26	314	-	43	-	-	-	-
1.42	353	50	63	1.27	316	-	41	-	-	-	-
1.43	356	48	61	-	-	-	-	-	-	-	-
1.44	358	46	59	-	-	-	-	-	-	-	-
1.45	361	44	56	-	-	-	-	-	-	-	-
1.46	363	42	54	-	-	-	-	-	-	-	-
1.47	366	40	52	-	-	-	-	-	-	-	-
1.48	368	-	50	-	-	-	-	-	-	-	-
1.49	371	-	48	-	-	-	-	-	-	-	-
1.50	373	-	46	-	-	-	-	-	-	-	-
1.51	376	-	44	-	-	-	-	-	-	-	-
1.52	378	-	42	-	-	-	-	-	-	-	-
1.53	381	-	40	-	-	-	-	-	-	-	-

## 36 AIRFLOW CHARTS (155 MAX 2019)

Speed 5				Speed 5				Speed 5			
Pressure Drop		Supply Airflow	Exhaust Airflow	Pressure Drop		Supply Airflow	Exhaust Airflow	Pressure Drop		Supply Airflow	Exhaust Airflow
("w.g.)	(Pa)	(cfm)	(cfm)	("w.g.)	(Pa)	(cfm)	(cfm)	("w.g.)	(Pa)	(cfm)	(cfm)
0.000	0	-	40	0.170	43	104	169	0.340	85	167	-
0.005	1	-	45	0.175	44	106	172	0.345	86	170	-
0.010	3	-	50	0.180	45	108	174	0.350	88	172	-
0.015	4	-	54	0.185	46	110	177	0.355	89	174	-
0.020	5	-	59	0.190	48	112	180	0.360	90	176	-
0.025	6	-	63	0.195	49	114	182	0.365	91	178	-
0.030	8	-	68	0.200	50	116	185	0.370	93	181	-
0.035	9	-	72	0.205	51	118	187	0.375	94	183	-
0.040	10	-	76	0.210	53	120	189	0.380	95	185	-
0.045	11	-	81	0.215	54	122	192	0.385	96	188	-
0.050	13	39	85	0.220	55	123	194	0.390	98	190	-
0.055	14	43	89	0.225	56	125	196	0.395	99	193	-
0.060	15	46	93	0.230	58	127	198	0.400	100	196	-
0.065	16	49	97	0.235	59	129	200	0.405	101	198	-
0.070	18	53	101	0.240	60	131	202	0.410	103	201	-
0.075	19	56	105	0.245	61	132	-	0.330	83	163	-
0.080	20	59	109	0.250	63	134	-	0.335	84	165	-
0.085	21	62	113	0.255	64	136	-	0.340	85	167	-
0.090	23	65	117	0.260	65	138	-	0.345	86	170	-
0.095	24	68	120	0.265	66	139	-	0.350	88	172	-
0.100	25	71	124	0.270	68	141	-	0.355	89	174	-
0.105	26	74	128	0.275	69	143	-	0.360	90	176	-
0.110	28	76	131	0.280	70	145	-	0.365	91	178	-
0.115	29	79	135	0.285	71	146	-	0.370	93	181	-
0.120	30	81	138	0.290	73	148	-	0.375	94	183	-
0.125	31	84	141	0.295	74	150	-	0.380	95	185	-
0.130	33	86	145	0.300	75	152	-	0.385	96	188	-
0.135	34	89	148	0.305	76	154	-	0.390	98	190	-
0.140	35	91	151	0.310	78	156	-	0.395	99	193	-
0.145	36	93	154	0.315	79	158	-	0.400	100	196	-
0.150	38	96	157	0.320	80	159	-	0.405	101	198	-
0.155	39	98	160	0.325	81	161	-	0.410	103	201	-
0.160	40	100	163	0.330	83	163	-				
0.165	41	102	166	0.335	84	165	-				

## 37 AIRFLOW CHARTS (205MAX)

The 205MAX units have three airflow charts for their installer adjustable fan curves. Refer to [Installer Selectable High Speed Settings](#) in this manual for instructions on how to adjust the circuit board DIP switches.

Hi 3				Hi 2				Hi 1			
Pressure Drop		Supply Airflow	Exhaust Airflow	Pressure Drop		Supply Airflow	Exhaust Airflow	Pressure Drop		Supply Airflow	Exhaust Airflow
("w.g.)	(Pa)	(cfm)	(cfm)	("w.g.)	(Pa)	(cfm)	(cfm)	("w.g.)	(Pa)	(cfm)	(cfm)
0.65	162	210	-	0.47	117	177	-	0.40	100	153	-
0.66	164	208	-	0.48	120	175	-	0.41	102	150	-
0.67	167	206	-	0.49	122	172	-	0.42	105	147	-
0.68	169	204	-	0.50	125	169	-	0.43	107	144	-
0.69	172	201	204	0.51	127	167	-	0.44	110	141	-
0.70	174	199	202	0.52	130	164	177	0.45	112	138	152
0.71	177	197	200	0.53	132	161	174	0.46	115	136	148
0.72	179	194	197	0.54	135	159	171	0.47	117	133	145
0.73	182	192	195	0.55	137	156	168	0.48	120	130	141
0.74	184	190	193	0.56	140	154	165	0.49	122	128	138
0.75	187	188	191	0.57	142	151	162	0.50	125	125	135
0.76	189	185	188	0.58	145	149	159	0.51	127	127	131
0.77	192	183	186	0.59	147	146	156	0.52	130	130	128
0.78	194	181	184	0.60	150	144	153	0.53	132	132	125
0.79	197	179	182	0.61	152	141	150	0.54	135	135	122
0.80	199	176	179	0.62	154	139	147	0.55	137	137	119
0.81	202	174	177	0.63	157	137	144	0.56	140	140	116
0.82	204	172	175	0.64	159	134	141	0.57	142	142	113
0.83	207	170	173	0.65	162	132	138	0.58	145	145	110
0.84	209	167	171	0.66	164	129	136	0.59	147	147	107
0.85	212	165	168	0.67	167	127	133	0.60	150	150	105
0.86	214	163	166	0.68	169	125	130	0.61	152	152	102
0.87	217	160	164	0.69	172	122	128	0.62	154	154	99
0.88	219	158	162	0.70	174	120	125	0.63	157	157	97
0.89	222	156	159	0.71	177	118	122	0.64	159	159	94
0.90	224	154	157	0.72	179	116	120	0.65	162	162	92
0.91	227	151	155	0.73	182	113	117	0.66	164	164	89
0.92	229	149	153	0.74	184	111	115	0.67	167	167	87
0.93	232	147	150	0.75	187	109	112	0.68	169	169	85
0.94	234	145	148	0.76	189	107	110	0.69	172	172	82
0.95	237	142	146	0.77	192	105	108	0.70	174	174	80
0.96	239	140	144	0.78	194	102	105	0.71	177	177	78
0.97	242	138	142	0.79	197	100	103	0.72	179	179	76
0.98	244	136	139	0.80	199	98	101	0.73	182	182	74
0.99	247	133	137	0.81	202	96	98	0.74	184	184	72
1.00	249	131	135	0.82	204	94	96	0.75	187	187	70
1.01	252	129	133	0.83	207	92	94	0.76	189	189	68
1.02	254	126	130	0.84	209	90	92	0.77	192	192	67

Continued next page ►

## 37 AIRFLOW CHARTS (205MAX)

The 205MAX units have three airflow charts for their installer adjustable fan curves. Refer to [Installer Selectable High Speed Settings](#) in this manual for instructions on how to adjust the circuit board DIP switches.

Hi 3				Hi 2				Hi 1			
Pressure Drop		Supply Airflow	Exhaust Airflow	Pressure Drop		Supply Airflow	Exhaust Airflow	Pressure Drop		Supply Airflow	Exhaust Airflow
("w.g.)	(Pa)	(cfm)	(cfm)	("w.g.)	(Pa)	(cfm)	(cfm)	("w.g.)	(Pa)	(cfm)	(cfm)
1.03	257	124	128	0.85	212	88	90	0.78	194	63	65
1.04	259	122	126	0.86	214	86	88	0.79	197	61	63
1.05	262	120	124	0.87	217	84	86	0.80	199	60	62
1.06	264	117	121	0.88	219	82	83	0.81	202	58	60
1.07	267	115	119	0.89	222	80	82	0.82	204	56	59
1.08	269	113	117	0.90	224	78	80	0.83	207	54	57
1.09	272	111	115	0.91	227	76	78	0.84	209	53	56
1.10	274	108	113	0.92	229	74	76	0.85	212	51	55
1.11	277	106	110	0.93	232	72	74	0.86	214	49	53
1.12	279	104	108	0.94	234	70	72	0.87	217	48	52
1.13	282	102	106	0.95	237	69	70	0.88	219	46	51
1.14	284	99	104	0.96	239	67	69	0.89	222	45	50
1.15	287	97	101	0.97	242	65	67	0.9	224	43	49
1.16	289	95	99	0.98	244	63	65	0.91	227	42	48
1.17	292	92	97	0.99	247	61	63	0.92	229	40	47
1.18	294	90	95	1.00	249	59	62	0.93	232	-	46
1.19	297	88	92	1.01	252	58	60	0.94	234	-	45
1.20	299	86	90	1.02	254	56	59	0.95	237	-	45
1.21	302	83	88	1.03	257	54	57	0.96	239	-	44
1.22	304	81	86	1.04	259	53	56	0.97	242	-	43
1.23	306	79	84	1.05	262	51	54	0.98	244	-	43
1.24	309	77	81	1.06	264	49	53	0.99	247	-	42
1.25	311	74	79	1.07	267	48	51	1.00	249	-	42
1.26	314	72	77	1.08	269	46	50	1.01	252	-	41
1.27	316	70	75	1.09	272	44	49	1.02	254	-	41
1.28	319	68	72	1.10	274	43	47	1.03	257	-	41
1.29	321	65	70	1.11	277	41	46	1.04	259	-	41
1.30	324	63	68	1.12	279	40	45	1.05	262	-	40
1.31	326	61	66	1.13	282	-	44	-	-	-	-
1.32	329	58	63	1.14	284	-	43	-	-	-	-
1.33	331	56	61	1.15	287	-	41	-	-	-	-
1.34	334	54	59	1.16	289	-	40	-	-	-	-
1.35	336	52	57	-	-	-	-	-	-	-	-
1.36	339	49	54	-	-	-	-	-	-	-	-
1.37	341	47	52	-	-	-	-	-	-	-	-
1.38	344	45	50	-	-	-	-	-	-	-	-
1.39	346	43	48	-	-	-	-	-	-	-	-
1.40	349	40	46	-	-	-	-	-	-	-	-
1.41	351	-	43	-	-	-	-	-	-	-	-
1.42	354	-	41	-	-	-	-	-	-	-	-

## 38 AIRFLOW CHARTS (267MAX)

The 267MAX units have three airflow charts for their installer adjustable fan curves. Refer to [Installer Selectable High Speed Settings](#) in this manual for instructions on how to adjust the circuit board DIP switches.

Hi 3				Hi 2				Hi 1			
Pressure Drop		Supply Airflow	Exhaust Airflow	Pressure Drop		Supply Airflow	Exhaust Airflow	Pressure Drop		Supply Airflow	Exhaust Airflow
("w.g.)	(Pa)	(cfm)	(cfm)	("w.g.)	(Pa)	(cfm)	(cfm)	("w.g.)	(Pa)	(cfm)	(cfm)
1.10	274	-	325	0.86	214	-	250	0.65	162	-	222
1.12	279	-	324	0.87	217	-	249	0.66	164	221	225
1.14	284	-	322	0.88	219	-	248	0.67	167	219	222
1.16	289	-	320	0.89	222	-	247	0.68	169	216	220
1.18	294	-	319	0.90	224	-	245	0.69	172	214	217
1.20	299	-	317	0.91	227	-	244	0.70	174	211	214
1.22	304	-	315	0.92	229	-	242	0.71	177	209	212
1.24	309	-	313	0.93	232	-	241	0.72	179	207	209
1.26	314	-	311	0.94	234	-	240	0.73	182	204	206
1.28	319	-	309	0.95	237	-	238	0.74	184	202	203
1.30	324	-	307	0.96	239	250	236	0.75	187	199	201
1.32	329	-	305	0.97	242	248	235	0.76	189	197	198
1.34	334	323	303	0.98	244	246	233	0.77	192	194	195
1.36	339	320	300	0.99	247	243	232	0.78	194	192	192
1.38	344	317	298	1.00	249	241	230	0.79	197	190	190
1.40	349	313	296	1.01	252	239	228	0.80	199	187	187
1.42	354	310	293	1.02	254	237	227	0.81	202	185	184
1.44	359	307	291	1.03	257	235	225	0.82	204	182	181
1.46	364	304	288	1.04	259	233	223	0.83	207	180	179
1.48	369	300	286	1.05	262	230	221	0.84	209	177	176
1.50	374	297	283	1.06	264	228	219	0.85	212	175	173
1.52	379	293	280	1.07	267	226	217	0.86	214	172	170
1.54	384	290	277	1.08	269	223	215	0.87	217	170	168
1.56	389	287	275	1.09	272	221	214	0.88	219	168	165
1.58	394	283	272	1.10	274	219	212	0.89	222	165	162
1.60	399	279	269	1.11	277	216	210	0.90	224	163	160
1.62	404	276	266	1.12	279	214	207	0.91	227	160	157
1.64	409	272	263	1.13	282	211	205	0.92	229	158	154
1.66	414	268	259	1.14	284	209	203	0.93	232	155	151
1.68	419	265	256	1.15	287	207	201	0.94	234	153	149
1.70	424	261	253	1.16	289	204	199	0.95	237	150	146
1.72	429	257	250	-	-	-	-	-	-	-	-
1.74	434	253	246	-	-	-	-	-	-	-	-

Continued next page ►

## 38 AIRFLOW CHARTS (267MAX)

The 267MAX units have three airflow charts for their installer adjustable fan curves. Refer to [Installer Selectable High Speed Settings](#) in this manual for instructions on how to adjust the circuit board DIP switches.

Hi 3				Hi 2				Hi 1			
Pressure Drop		Supply Airflow	Exhaust Airflow	Pressure Drop		Supply Airflow	Exhaust Airflow	Pressure Drop		Supply Airflow	Exhaust Airflow
("w.g.)	(Pa)	(cfm)	(cfm)	("w.g.)	(Pa)	(cfm)	(cfm)	("w.g.)	(Pa)	(cfm)	(cfm)
1.76	439	249	243	1.19	297	196	192	0.98	244	143	138
1.78	444	245	239	1.20	299	194	190	0.99	247	141	135
1.80	449	241	236	1.21	302	191	188	1.00	249	138	132
1.82	453	237	232	1.22	304	189	185	1.01	252	136	129
1.84	458	233	229	1.23	306	186	183	1.02	254	133	127
1.86	463	229	225	1.24	309	183	180	1.03	257	131	124
1.88	468	225	221	1.25	311	181	178	1.04	259	129	121
1.90	473	220	217	1.26	314	178	175	1.05	262	126	119
1.92	478	216	213	1.27	316	175	173	1.06	264	124	116
1.94	483	212	209	1.28	319	172	170	1.07	267	121	113
1.96	488	207	205	1.29	321	169	168	1.08	269	119	110
1.98	493	203	201	1.30	324	167	165	1.09	272	116	108
2.00	498	199	197	1.31	326	164	162	1.10	274	114	105
2.02	503	194	193	1.32	329	161	160	1.11	277	111	102
2.04	508	190	189	1.33	331	158	157	1.12	279	109	99
2.06	513	185	184	1.34	334	155	154	1.13	282	107	97
2.08	518	180	180	1.35	336	152	151	1.14	284	104	94
2.10	523	176	176	1.36	339	149	149	1.15	287	102	91
2.12	528	171	171	1.37	341	146	146	1.16	289	99	88
2.14	533	166	167	1.38	344	143	143	1.17	292	97	86
2.16	538	162	162	1.39	346	140	140	1.18	294	94	83
2.18	543	157	157	1.40	349	137	137	1.19	297	92	80
2.20	548	152	153	1.41	351	134	134	1.20	299	90	77
2.22	553	147	148	1.42	354	131	131	0.98	244	143	138
2.24	558	142	143	1.43	356	128	128	0.99	247	141	135
2.26	563	137	138	1.44	359	125	125	1.00	249	138	132
2.28	568	132	133	1.45	361	122	122	1.01	252	136	129
2.30	573	127	128	1.46	364	119	119	1.02	254	133	127
2.32	578	122	123	1.47	366	115	116	1.03	257	131	124
2.34	583	117	118	1.48	369	112	112	1.04	259	129	121
2.36	588	112	113	1.49	371	109	109	1.05	262	126	119
2.38	593	106	107	1.50	374	106	106	1.06	264	124	116
2.40	598	101	102	1.51	376	102	103	1.07	267	121	113

## 39 TROUBLESHOOTING

Refer to the following table for troubleshooting the HRV unit.

**Troubleshooting Procedures Table**

SYMPTOM	CAUSE	SOLUTION
Poor airflows	<ul style="list-style-type: none"> <li>• 1/4 in (6mm) mesh on outside hood is plugged</li> <li>• Filters plugged</li> <li>• Core obstructed</li> <li>• House grilles closed or blocked</li> <li>• Dampers are closed if installed</li> <li>• Poor power supply at site</li> <li>• Ductwork is restricting HRV</li> <li>• Improper speed control setting</li> <li>• HRV airflow improperly balanced</li> </ul>	<ul style="list-style-type: none"> <li>• Clean exterior hoods or vents</li> <li>• Remove and clean filter</li> <li>• Remove and clean core</li> <li>• Check and open grilles</li> <li>• Open and adjust dampers</li> <li>• Have electrician check supply voltage</li> <li>• Check duct installation</li> <li>• Increase the speed of the HRV</li> <li>• Have contractor balance HRV</li> </ul>
Supply air feels cold	<ul style="list-style-type: none"> <li>• Poor location of supply grilles, the airflow may irritate the occupant</li> <li>• Outdoor temperature extremely cold</li> </ul>	<ul style="list-style-type: none"> <li>• Locate the grilles high on the walls or under the baseboards, install ceiling mounted diffuse or grilles so as not to directly spill the supply air on the occupant (i.e., over a sofa)</li> <li>• Turn down the HRV supply speed. A small duct heater (1 kW) could be used to temper the supply air</li> <li>• Placement of furniture or closed doors is restricting the movement of air in the home</li> <li>• If supply air is ducted into furnace return, the furnace fan may need to run continuously to distribute ventilation air comfortably</li> </ul>
Dehumidistat is not operating	<ul style="list-style-type: none"> <li>• Outdoor temperature is above 15°C (59°F)</li> <li>• Improper low voltage connection</li> <li>• External low voltage is shortened out by a staple or nail</li> <li>• Check dehumidistat setting it may be on OFF</li> </ul>	<ul style="list-style-type: none"> <li>• Dehumidistat is functioning normally (see Auto Dehumidistat Disable in this manual)</li> <li>• Check that the correct terminals have been used</li> <li>• Check external wiring for a short</li> <li>• Set the dehumidistat at the desired setting</li> </ul>
Humidity levels are too high condensation is appearing on the windows	<ul style="list-style-type: none"> <li>• Dehumidistat is set too high</li> <li>• HRV is not sized to handle a hot tub, indoor pool etc.</li> <li>• Lifestyle of the occupants Moisture coming into the home from an unvented or unheated crawl space</li> <li>• Moisture is remaining in the washroom and kitchen areas</li> <li>• Condensation seems to form in the spring and fall</li> <li>• HRV is set at too low a speed</li> </ul>	<ul style="list-style-type: none"> <li>• Set dehumidistat lower</li> <li>• Cover pools, hot tubs when they are not in use</li> <li>• Avoid hanging clothes to dry, storing wood and venting clothes dryer inside. Firewood may have to be moved outside</li> <li>• Vent crawl space and place a vapor barrier on the floor of the crawl space</li> <li>• Ducts from the washroom should be sized to remove moist air as effectively as possible, use of a bathroom fan for short periods will remove additional moisture</li> <li>• On humid days, as the seasons change, some condensation may appear, but the homes air quality will remain high with some HRV use Increase speed of the HRV</li> </ul>

## 39 TROUBLESHOOTING

Refer to the following table for troubleshooting the HRV unit.

**Troubleshooting Procedures Table (cont.)**

SYMPTOM	CAUSE	SOLUTION
Humidity levels are too low	<ul style="list-style-type: none"> <li>• Dehumidistat control set too low</li> <li>• Blower speed of HRV is too high</li> <li>• Lifestyle of occupants</li> <li>• HRV airflows may be improperly balanced</li> </ul>	<ul style="list-style-type: none"> <li>• Set dehumidistat higher</li> <li>• Decrease HRV blower speed</li> <li>• Humidity may have to be added using humidifiers</li> <li>• Have contractor balance HRV airflows</li> </ul>
HRV and/or ducts frosting up	<ul style="list-style-type: none"> <li>• HRV airflows are improperly balanced</li> <li>• Malfunction of the HRV defrost system</li> </ul>	<div style="border: 1px solid black; padding: 5px; margin-bottom: 10px;"> <p><b>Note</b></p> <ul style="list-style-type: none"> <li>• Minimal frost build-up is expected on cores before unit initiates defrost cycle functions</li> </ul> </div> <ul style="list-style-type: none"> <li>• Have HVAC contractor balance the HRV</li> <li>• Ensure damper defrost is operating during self-test</li> </ul>
Condensation or ice buildup in insulated duct to the outside	<ul style="list-style-type: none"> <li>• Incomplete vapor barrier around insulated duct</li> <li>• A hole or tear in outer duct covering</li> </ul>	<ul style="list-style-type: none"> <li>• Tape and seal all joints</li> <li>• Tape any holes or tears made in the outer duct cover, ensure that the vapor barrier is completely sealed.</li> </ul>
Excess water in the bottom of the HRV	<ul style="list-style-type: none"> <li>• Drain pans plugged</li> <li>• Improper connection of HRV's drain lines</li> <li>• HRV is not level</li> <li>• Drain lines are obstructed</li> <li>• HRV heat exchange core is not properly installed</li> </ul>	<ul style="list-style-type: none"> <li>• Look for obstructions in the drain line</li> <li>• Look for kinks in the drain line</li> </ul>
Excessive Vibration	<ul style="list-style-type: none"> <li>• Dirt on fan wheels</li> </ul>	<ul style="list-style-type: none"> <li>• Have contractor service HRV</li> </ul>